



Methods for Derivation of Inhalation Reference Concentrations and Application of Inhalation Dosimetry

EPA/600/8-90/066F
October 1994

METHODS FOR DERIVATION OF INHALATION REFERENCE CONCENTRATIONS AND APPLICATION OF INHALATION DOSIMETRY

**Environmental Criteria and Assessment Office
Office of Health and Environmental Assessment
Office of Research and Development
U.S. Environmental Protection Agency
Research Triangle Park, NC 27711**

DISCLAIMER

This document has been reviewed in accordance with U.S. Environmental Protection Agency policy and approved for publication. Mention of trade names or commercial products does not constitute endorsement or recommendation for use.

TABLE OF CONTENTS

	<u>Page</u>
LIST OF TABLES	vi
LIST OF FIGURES	viii
AUTHORS, CONTRIBUTORS, AND REVIEWERS	xiii
LIST OF ACRONYMS AND ABBREVIATIONS	xix
GLOSSARY	xxvii
1. INTRODUCTION AND OVERVIEW	1-1
1.1 INHALATION REFERENCE CONCENTRATION: DEVELOPMENT, DEFINITION, AND DERIVATION	1-1
1.2 GENERAL PRINCIPLES OF DOSE-RESPONSE ASSESSMENT FOR NONCANCER TOXICITY	1-8
1.3 GUIDELINES ON SPECIFIC ENDPOINTS	1-14
1.4 USE OF THE INHALATION REFERENCE CONCENTRATION IN THE NATIONAL ACADEMY OF SCIENCES RISK ASSESSMENT AND RISK MANAGEMENT PARADIGM	1-15
1.5 OCCUPATIONAL EXPOSURE LIMITS VERSUS INHALATION REFERENCE CONCENTRATIONS	1-16
1.6 PRIMARY NATIONAL AMBIENT AIR QUALITY STANDARDS VERSUS INHALATION REFERENCE CONCENTRATIONS	1-17
1.7 STATE-OF-THE-ART APPLICATIONS TO THE DEVELOPMENT OF THE INHALATION REFERENCE CONCENTRATION METHODOLOGY	1-18
2. QUALITATIVE EVALUATION OF THE DATA BASE	2-1
2.1 GUIDELINES FOR SELECTIONS OF KEY STUDIES	2-2
2.1.1 Human Data	2-2
2.1.1.1 Molecular Epidemiology and Biologic Markers	2-3
2.1.1.2 Epidemiologic Data	2-16
2.1.1.3 Nonepidemiologic Data	2-20
2.1.1.4 Intraspecies Variability and Identifying Sensitive Subgroups	2-22
2.1.1.5 Summary	2-24
2.1.2 Laboratory Animal Data	2-26
2.1.2.1 Study Design	2-26
2.1.2.2 Impact of Experimental Protocol	2-27
2.1.2.3 Appropriateness of Laboratory Animal Species as a Model for Humans	2-35
2.1.2.4 Study Validity and Relevance to Extrapolation	2-43
2.1.3 Summarizing the Evidence	2-44

TABLE OF CONTENTS (cont'd)

	<u>Page</u>
3. CONCEPTUAL BASIS FOR INHALATION DOSE-RESPONSE ASSESSMENT METHODOLOGY	3-1
3.1 FACTORS CONTROLLING COMPARATIVE INHALED DOSE	3-1
3.1.1 Respiratory Anatomy and Physiology	3-3
3.1.1.1 Respiratory Regions and Branching Patterns . .	3-3
3.1.1.2 Clearance Mechanisms	3-18
3.1.2 Physicochemical Characteristics of the Inhaled Toxicant	3-29
3.1.2.1 Particles	3-30
3.1.2.2 Gases and Vapors	3-30
3.2 MODELING COMPARATIVE DOSIMETRY OF INHALED TOXICANTS	3-34
3.2.1 Particle Disposition Model Based on Available Data	3-35
3.2.2 Gas Categorization Scheme Directs Default Gas Modeling	3-36
3.2.3 Summary Considerations for Judging Model Structures	3-39
4. QUANTITATIVE PROCEDURES	4-1
4.1 MINIMUM DATA BASE CRITERIA	4-2
4.1.1 Evaluation of Comprehensiveness	4-2
4.1.2 Route-to-Route Extrapolation	4-5
4.1.3 Not-Verifiable Status	4-12
4.2 DESIGNATION OF EFFECT LEVELS	4-12
4.3 CALCULATION OF HUMAN EQUIVALENT CONCENTRATIONS	4-17
4.3.1 Conversion to Standard Units	4-19
4.3.2 Temporal Relationships of Toxicity and Duration Adjustment	4-20
4.3.3 Use of Pharmacokinetic and Pharmacodynamic Data . . .	4-22
4.3.4 Default Dosimetric Adjustment and Physiological Parameters	4-25
4.3.5 Dosimetric Adjustments for Particle Exposures	4-29
4.3.5.1 Respiratory Effects	4-37
4.3.5.2 Remote (Extrarespiratory) Effects	4-38
4.3.5.3 Additional Issues for Particle Dosimetry	4-39
4.3.6 Dosimetric Adjustments for Gas Exposures	4-44
4.3.6.1 Respiratory Effects	4-46
4.3.6.2 Remote (Extrarespiratory) Effects	4-57
4.3.6.3 Additional Assumptions and Default Values . .	4-63
4.3.7 Derivation and Dosimetric Adjustment Using Human Studies	4-64

TABLE OF CONTENTS (cont'd)

	<u>Page</u>	
4.3.7.1	Selecting the Threshold Estimate	4-65
4.3.7.2	Defining the Exposure Level	4-65
4.3.7.3	Dosimetric Adjustment for Human Data	4-66
4.3.7.4	Uncertainty Factors for Human Data	4-67
4.3.8	Data Array Evaluation and Choice of Principal Study/Studies	4-68
4.3.9	Operational Derivation of the Inhalation Reference Concentration	4-70
4.3.9.1	Application of Uncertainty Factors	4-73
4.3.9.2	Assignment of Confidence Levels	4-80
5.	REFERENCES	5-1
	APPENDIX A—Alternative Approaches to the Estimation of No-Observed-Adverse-Effect Levels	A-1
	APPENDIX B—Criteria for Assessing the Quality of Individual Epidemiological Studies	B-1
	APPENDIX C—Criteria for Causal Significance	C-1
	APPENDIX D—Adverse Human Respiratory Health Effects	D-1
	APPENDIX E—Guidance on Pulmonary Function Testing	E-1
	APPENDIX F—Criteria for Assessing the Quality of Individual Laboratory Animal Toxicity Studies	F-1
	APPENDIX G—The Particle Deposition Dosimetry Model	G-1
	APPENDIX H—Particle Sizing Conventions	H-1
	APPENDIX I—Derivation of an Approach To Determine Human Equivalent Concentrations for Effects of Exposures to Gases in Categories 1 and 2	I-1
	APPENDIX J—Derivation of an Approach To Determine Human Equivalent Concentrations for Extrarespiratory Effects of Category 3 Gas Exposures Based on a Physiologically Based Pharmacokinetic Model Using Selected Parameter Values	J-1

LIST OF TABLES

<u>Number</u>		<u>Page</u>
2-1	Steps in the Development of a Biomarker	2-8
2-2	Qualitative Rating for Validity of Biologic Markers	2-10
2-3	Comparison of the Qualities of Field and Experimental Approaches in the Study of Threshold Limit Value/Biologic Exposure Indices Relationships	2-15
2-4	Prevalence of Subgroups Susceptible to Effects of Common Pollutants	2-23
2-5	Agents Causing Wheezing and Bronchoconstriction	2-41
2-6	Approach for Summarizing the Evidence from Diverse Data	2-45
2-7	Human Data for Use in Health Risk Assessment	2-46
3-1	Respiratory Tract Regions	3-4
3-2	Comparative Lower Airway Anatomy as Revealed on Casts	3-8
3-3	Normal Surface Airway Epithelium: Cell Types	3-23
3-4	Some Specific Lung Cell Types and Their Functions	3-24
3-5	Main Species Differences in Epithelial Cells and Glands	3-25
3-6	Hierarchy of Model Structures for Dosimetry and Interspecies Extrapolation	3-40
4-1	Minimum Data Base for Both High and Low Confidence in the Inhalation Reference Concentration	4-3
4-2	Four Types of Effect Levels Considered in Deriving Inhalation Reference Concentrations for Noncancer Toxicity	4-14
4-3	Effect Levels Considered in Deriving Inhalation Reference Concentrations in Relationship to Empirical Severity Rating Values	4-16
4-4	Default Surface Area Values for Respiratory Effects	4-26
4-5	Body Weight Default Values—Rats	4-28

LIST OF TABLES (cont'd)

<u>Number</u>		<u>Page</u>
4-6	Intercept and Coefficient Values Used in Algorithm To Calculate Default Minute Volumes Based on Body Weight	4-29
4-7	Comparison of the Highest Individual Species NOAEL _[HEC] and Its LOAEL _[HEC]	4-71
4-8	Guidelines for the Use of Uncertainty Factors in Deriving Inhalation Reference Concentration	4-76
4-9	The Use of Uncertainty Factors in Deriving an Inhalation Reference Concentration	4-77
E-1	Definition of Various Pulmonary Function Test Volumes and Capacities	E-4
E-2	Change in Spirometric Indices Over Time	E-17
F-1	General Clinical Biochemistry Examinations	F-5
F-2	Organs and Tissues Preserved for Histological Examination	F-6
G-1	Regional Fractional Deposition	G-4
G-2	Deposition Efficiency Equation Estimated Parameters	G-6
H-1	Particle Diameter Definitions	H-5
H-2	Lognormal Conversion Equations for Common Types of Diameters	H-7
H-3	Percentage of Particles in the Reported Range Associated with the Number of Standard Deviations Used To Calculate the Geometric Standard Deviation	H-10
H-4	General Particle Descriptions and Associated Sizes	H-12
I-1	Definition of Parameter Symbols Used in Appendix I	I-9
J-1	Definition of Symbols	J-5

LIST OF FIGURES

<u>Number</u>		<u>Page</u>
1-1	National Research Council (1983) framework for risk assessment and risk management	1-2
1-2	Schematic characterization of comprehensive exposure-dose-response continuum and the evolution of protective to predictive dose-response estimates	1-11
2-1	Biological marker components in sequential progression between exposure and disease	2-4
2-2	Schematic representation of possible relationships to research using biologic markers	2-11
2-3	Schematic relationships between threshold limit values in air, biologic exposure indices, and effects	2-13
3-1	Diagrammatic representation of three respiratory tract regions	3-5
3-2	Schematic representation of selected parameters influencing regional deposition of particles in the respiratory tract	3-9
3-3	Regional deposition in humans of monodisperse particles by indicated particle diameter for mouth breathing and nose breathing	3-10
3-4	Schematic representation of selected parameters influencing regional deposition of gases in the respiratory tract	3-11
3-5	Net dose of ozone versus sequential segments along anatomical model lower respiratory tract paths for human, rat, guinea pig, and rabbit	3-12
3-6	Diagram of the nasal passages for the F344 rat modified from Morgan et al. (1984)	3-15
3-7	Diagram of the nasal passages for the Rhesus monkey modified from Monticello et al. (1989)	3-16
3-8	Inspiratory airflow patterns in upper respiratory tract of Fischer 344 rat and Rhesus monkey	3-17
3-9	Gas categorization scheme based on water solubility and reactivity as major determinants of gas uptake	3-37

LIST OF FIGURES (cont'd)

<u>Number</u>		<u>Page</u>
4-1	Multiple route comparisons for mice and humans administered chloroform at a dose of 100 milligrams per kilogram body weight	4-7
4-2	Differential effects of inhaled and ingested cadmium with increasing inhaled and ingested doses	4-8
4-3	Decision tree for route-to-route extrapolation	4-10
4-4	Flowchart for calculation of human equivalent concentrations	4-18
4-5	Display Screen 1 of the computer program that calculates regional deposited dose ratios	4-33
4-6	Display Screen 2 of the program that calculates regional deposited dose ratios	4-33
4-7	Display Screen 3 of the computer program that calculates regional deposited dose ratios	4-34
4-8	Display Screen 4 of the computer program that calculates regional deposited dose ratios	4-34
4-9	Time course of periodicity for Fischer 344 rat exposed 6 hours per day, 5 days per week to theoretical gas with partition coefficients as shown	4-61
4-10	Relationship of blood:gas and fat:blood partition coefficients to the attainment of periodic blood concentrations in the Fischer 344 rat	4-62
4-11	Example data array and inhalation reference concentration derivation	4-72
A-1	Graphical illustration of proposed low-dose risk estimation for the proportion of abnormal responses in developmental toxicity	A-7
A-2	Schematic of computing a posterior distribution from a likelihood function and a prior distribution	A-12
A-3	Incidence of nasal turbinate lesions in B6C3F1 female mice exposed to <i>n</i> -hexane for 13 weeks	A-13
A-4	Posterior distribution for the <i>n</i> -hexane concentration associated with the specified health effect in Figure A-3	A-13

LIST OF FIGURES (cont'd)

<u>Number</u>		<u>Page</u>
A-5	Posterior distribution for the concentration of <i>n</i> -hexane associated with the specified health effects from the combined evidence of Sanagi et al. (1980) and Dunnick et al. (1989)	A-14
A-6	Posterior distributions for the manganese concentration associated with specified health effects from each of three studies: Roels et al. (1987a), Iregren (1990), and Chandra et al. (1981)	A-15
A-7	Posterior distribution for the manganese concentration associated with specified health effect using either exposure or estimated exposure distribution	A-16
A-8	Posterior distribution for the concentration of manganese associated with specified health effect from the combined evidence of Iregren (1990) and Roels et al. (1987a) with fixed exposure	A-16
A-9	Posterior distribution for the concentration of manganese associated with specified health effect from the combined evidence of Iregren (1990) and Roels et al. (1987a,b) with exposure distribution	A-17
A-10	Categorical data from published results on methyl isocyanate for exposures of less than 8 hours in duration and shown as NOAEL, AEL, or lethality	A-20
A-11	Categorical data from published results as in Figure A-10, excluding lethality data	A-22
A-12	Categorical regression analysis for data on carboxyhemoglobin in humans	A-22
A-13	Categorical regression analysis of tetrachloroethylene: acute effects	A-23
E-1	Lung volumes and capacities	E-3
E-2	Volume-time plot (spirogram) of the forced vital capacity maneuver	E-6
G-1	Comparison of regional deposition efficiencies and fractions for the mouse	G-10
G-2	Range of particles for lognormal distributions with same mass median aerodynamic diameter but differing geometric standard deviations	G-12

LIST OF FIGURES (cont'd)

<u>Number</u>		<u>Page</u>
G-3	Regional deposited dose ratios for rat:human as a function of mass median aerodynamic diameter for monodisperse and polydisperse particle size distributions	G-14
H-1	An example of the log-normal distribution function of an aerosol	H-4
H-2	Plot of same aerosol as in Figure H-1 on log-probability paper	H-6
H-3	Measurement ranges of aerosol monitoring instruments	H-8
H-4	Various airborne materials and their size ranges	H-11
I-1	Gas categorization scheme based on water solubility and reactivity as major determinants of gas uptake	I-5
I-2	Schematic of two-phase mass transport resistance model	I-13
I-3	Schematic of modeling approach to estimate regional respiratory tract dose of gases	I-18
I-4	Bohr model of ventilation and uptake	I-29
I-5	Schematic of physiologically based pharmacokinetic modeling approach to estimate respiratory tract dose of gases in Category 2	I-37
I-6	Schematic of surface-liquid/tissue phase concentration during exhalation	I-40
I-7	Schematic of change in surface-liquid/tissue phase concentration with distance and time	I-41
I-8	Schematic of change in mass during breathing cycle	I-42
J-1	Schematic of the physiologically based pharmacokinetic model assumed to describe the uptake and distribution of inhaled compounds	J-4
J-2	Plot of $NOAEL^*_{[HEC]}$ versus $NOAEL^*_{[A]}$ for the rat for four possible methods of determining $NOAEL_{[HEC]}$ estimates as defined in the text	J-15
J-3	Plot of $NOAEL^*_{[HEC]}$ versus $NOAEL^*_{[A]}$ for the mouse for four possible methods of determining $NOAEL^*_{[HEC]}$ estimates as defined in the text	J-16

AUTHORS, CONTRIBUTORS, AND REVIEWERS

This document was prepared under the direction of the Environmental Criteria and Assessment Office (ECAO) in Research Triangle Park, NC, of the Office of Health and Environmental Assessment (OHEA) within the U.S. Environmental Protection Agency's (EPA's) Office of Research and Development (ORD).

The principal authors are:

Annie M. Jarabek
Environmental Criteria and Assessment Office
Office of Health and Environmental Assessment
U.S. Environmental Protection Agency
Research Triangle Park, NC 27711

Linda Hanna, Ph.D.
Sciences International, Inc.
King Street Station
1800 Diagonal Road, Suite 500
Alexandria, VA 22314

Margaret Ménache
Center for Extrapolation Modeling
Duke University Medical Center
Durham, NC 27710

John Overton, Jr., Ph.D.
Health Effects Research Laboratory
Office of Health Research
U.S. Environmental Protection Agency
Research Triangle Park, NC 27711

The contributing authors to the current document, listed in alphabetical order, are:

Michael Dourson, Ph.D.
Environmental Criteria and Assessment Office
Office of Health and Environmental Assessment
U.S. Environmental Protection Agency
Cincinnati, OH 45268

Linda Erdreich, Ph.D.*
Environmental Research Information, Inc.
New York, NY 10018-3011

Judith A. Graham, Ph.D.
Environmental Criteria and Assessment Office
Office of Health and Environmental Assessment
U.S. Environmental Protection Agency
Research Triangle Park, NC 27711

Elaine C. Grose, Ph.D.[†]
537 Venard Rd.
Clark Summit, PA 18411

Mary Jane Selgrade, Ph.D.
Health Effects Research Laboratory
Office of Health Research
U.S. Environmental Protection Agency
Research Triangle Park, NC 27711

*Formerly with ECAO—Cincinnati.

[†]Formerly with the Health Effects Research Laboratory—RTP.

The authors are also grateful to several other individuals who contributed to the development of earlier versions of the methodology. Their thoughtful discussions at that time were useful in delineating important issues. These individuals, listed in alphabetical order, are:

Karen Blackburn, Ph.D.*
Proctor and Gamble
Cincinnati, OH

Christopher DeRosa, Ph.D.*
Agency for Toxic Substances and Disease
Registry
Atlanta, GA

Mark Greenberg, M.S.
Environmental Criteria and Assessment Office
Office of Health and Environmental Assessment
U.S. Environmental Protection Agency
Research Triangle Park, NC 27711

Richard Hertzberg, Ph.D.
Environmental Criteria and Assessment Office
Office of Health and Environmental Assessment
U.S. Environmental Protection Agency
Cincinnati, OH 45268

Bruce Peirano, Ph.D.
Environmental Criteria and Assessment
Office
Office of Health and Environmental
Assessment
U.S. Environmental Protection Agency
Cincinnati, OH 45268

William Pepelko, Ph.D.
Human Health Assessment Group
Office of Health and Environmental
Assessment
U.S. Environmental Protection Agency
Washington, DC 20460

Greg Theiss, Ph.D.
Office of Program Planning and Evaluation
Office of Research and Development
U.S. Environmental Protection Agency
Washington, DC 20450

*Formerly with ECAO—Cincinnati.

Lastly, the authors thank Bette Zwyer and Carol Haynes (ECAO-Cincinnati) for diligently and graciously preparing the original drafts of the manuscript and Judith Olsen for excellent editorial support. The authors further thank Marianne Barrier, John Barton, Ivra Bunn, Lynette Cradle, Patricia Felix, Jorja Followill, Miriam Gattis, Lorrie Godley, Sheila Lassiter, and Wendy Lloyd of ManTech Environmental Technology, Inc. (Research Triangle Park, NC), for preparing several drafts for reviews (experts workshop, EPA's Science Advisory Board [SAB], and external peer) as well as the current, final document. The authors also are grateful to Donald Joyner of the Chemical Industry Institute of Toxicology for graphics support. Lastly, the authors express a special tribute to the late Director of ECAO—Cincinnati, Dr. Jerry F. Stara—his vision initiated the effort.

The following individuals participated as peer reviewers at a publicly held expert review at the EPA Environmental Research Center in Research Triangle Park, NC, on October 5 and 6, 1987, and provided valuable comments and written contributions on both the workshop draft and a subsequently revised draft:

Charles Hobbs, D.V.M.
Inhalation Toxicology Research Institute
Lovelace Biomedical and Environmental
Research Institute, Inc.
P.O. Box 5890
Albuquerque, NM 87185

Michael D. Lebowitz, Ph.D.
University of Arizona College of Medicine
Respiratory Sciences Center
1501 North Campbell Avenue
Tucson, AZ 85724

Daniel B. Menzel, Ph.D.*
Laboratory of Environmental Pharmacology
and Toxicology
P.O. Box 3813
Duke University Medical Center
Durham, NC 27710

Richard Schlesinger, Ph.D.
Laboratory for Pulmonary Biology and
Toxicology
Institute of Environmental Medicine
New York University Medical Center
Long Meadow Road
Tuxedo, NY 10987

Vera Fisgrova-Bergerova Thomas, Ph.D.
Department of Anesthesiology
University of Miami School of Medicine
P.O. Box 016370
Miami, FL 33101

Theodore Torkelson, Ph.D.
Toxicology Consultant
315 Birch Street
Roscommon, MI 48653

Curtis Travis, Ph.D.
Center for Risk Management
P.O. Box 2008
Building 4500S
Oak Ridge National Laboratory
Oak Ridge, TN 37831-6109

*Current address:

Department of Community and Environmental
Medicine
University of California—Irvine
Irvine, CA 92717.

On October 26, 1990, an external review draft (1990) of this document was reviewed by EPA's Science Advisory Board (SAB). The SAB reviewers were:

ACTING CHAIRMAN

Ronald Wyzga, Ph.D.
Electric Power Research Institute
3412 Hillview Avenue
P.O. Box 10412
Palo Alto, CA 94303

Richard Monson, Ph.D.
Department of Epidemiology
Harvard School of Public Health
677 Huntington Ave.
Boston, MA

MEMBERS AND CONSULTANTS

Mel Andersen, Ph.D.*
Chemical Industry Institute of Toxicology
P.O. Box 12137
6 Davis Drive
Research Triangle Park, NC 27709

D. Warner North, Ph.D.
Decision Focus Inc.
650 Castro Street, Suite 300
Mountain View, CA 94041

David Gaylor, Ph.D.
Biometry Division
National Center for Toxicological Research
Jefferson, AR 72079

Guenter Oberdörster, Ph.D.
Department of Environmental Medicine
University of Rochester School of Medicine
Rochester, NY 14642

Marshall Johnson, Ph.D.
Department of Anatomy and Developmental
Biology
Jefferson Medical College
1020 Locust Street
Philadelphia, PA 19107

Martha Radike, Ph.D.
Department of Environmental Health
University of Cincinnati Medical Center
3223 Eden Avenue
Cincinnati, OH 45267

Fred Miller, Ph.D.†
Center for Extrapolation Modeling
Duke University Medical Center
Durham, NC 27710

Bernard Weiss, Ph.D.
Department of Environmental Medicine
University of Rochester School of Medicine
Rochester, NY 14642

*Current address:
ICF Kaiser
1 Copley Park, Suite 102
Morrisville, NC 27650

†Current address:
Department of Inhalation Toxicology and
Biomathematical Modeling
Chemical Industry Institute of Toxicology
P.O. Box 12137
6 Davis Drive
Research Triangle Park, NC 27709.

After the 1990 SAB review, the document was revised and an additional peer review was conducted in August* and September† 1993 to evaluate the key revisions made in response to SAB comments. The following experts participated:

Alan Dahl, Ph.D.*†
Inhalation Toxicology Research Institute
Lovelace Biomedical and Environmental
Research Institute, Inc.
P.O. Box 5890
Albuquerque, NM 87185-5890

Vera Fiserova-Bergerova Thomas, Ph.D.*
Department of Anesthesiology
University of Miami School of Medicine
P.O. Box 016370
Miami, FL 33101

Clay B. Frederick, Ph.D.*†
Toxicology Department
Rohm and Haas Company
727 Norristown Road
Spring House, PA 19477

Michael D. Lebowitz, Ph.D.*
University of Arizona College of Medicine
Respiratory Sciences Center
1501 North Campbell Avenue
Tucson, AZ 85724

John Morris, Ph.D.*†
Department of Pharmacology and Toxicology
University of Connecticut
Storrs, CT 06269-2092

Curtis C. Travis, Ph.D.*
Center for Risk Management
P.O. Box 2008 Building 4500S
Oak Ridge National Laboratory
Oak Ridge, TN 37831-6109

James S. Ultman, Ph.D.*†
Department of Chemical Engineering
Penn State University
106 Fenske Laboratory
University Park, PA 16802

Ron K. Wolff, Ph.D.*
Lily Research Laboratories
P.O. Box 708
Greenfield, IN 46140

LIST OF ACRONYMS AND ABBREVIATIONS

a	Airway perimeter
ADI	Acceptable daily intake
BEIs	Biologic exposure indices
bw	Body weight
C_0	Initial concentration
C_{alv}	Pulmonary region gas concentration
$C_a(x)$	Gas concentration as a function of x
C_b	Blood concentration
$C_{b/g}$	Gas concentration in equilibrium with blood concentration
$C_{b/r}$	Concentration of gas in its chemically transformed (reacted) state
C_f	Concentration in the fat compartment
C_g	Gas phase concentration in airway lumen
C_{gi}	Gas-phase concentration at the interface of the gas phase with the surface liquid/tissue phase
C_i	Inhaled concentration
C_l	Surface-liquid/tissue phase concentration
C_{LG}	Concentration in the lung compartment
$C_{l/g}$	Surface-liquid/tissue concentration in equilibrium with the gas phase
C_{li}	Surface-liquid/tissue concentration at the interface of the gas phase and the surface-liquid/tissue phase
C_s	Imposed concentration
$C_{T/A}$	Concentration of reacted and unreacted gas in arterial blood
$C_{T/V}$	Concentration of reacted and unreacted gas in venous blood

LIST OF ACRONYMS AND ABBREVIATIONS (cont'd)

C_Z	Concentration in the surface-liquid/tissue phase
CA	Arterial (unoxygenated) blood concentration (mg/cm^3)
CL_{fat}	Clearance from the fat compartment
CL_{LIV}	Clearance from the liver compartment
CL_{SYS}	Clearance from the systemic compartment
CNS	Central nervous system
CV	Concentration in venous (oxygenated) blood entering gas-exchange (PU) region
$CX(\text{EXH})_{\text{ET}}$	Concentration exiting from extrathoracic region on exhalation
$CX(\text{EXH})_{\text{PU}}$	Concentration exiting from pulmonary region on exhalation
$CX(\text{EXH})_{\text{TB}}$	Concentration exiting from tracheobronchial region on exhalation
$CX(\text{INH})_{\text{ET}}$	Concentration exiting from extrathoracic region on inhalation
$CX(\text{INH})_{\text{TB}}$	Concentration exiting from tracheobronchial region on inhalation
D	Deposited fraction of mass
D_1	Liquid diffusivity
d_{ae}	Aerodynamic equivalent diameter
d_{ar}	Aerodynamic resistance diameter
DAF	Dosimetric adjustment factor
DNA	Deoxyribonucleic acid
d_p	Particle diameter
dx	Differential of axial distance into airway
dy	Differential of axial distance into capillary segment
dz	Differential of distance into the surface-liquid/tissue phase

LIST OF ACRONYMS AND ABBREVIATIONS (cont'd)

\dot{E}_{LG}	Elimination rate in the lung compartment
E_{MAX}	Maximum extraction efficiency
E_T	Liver extraction efficiency
ER	Extrarespiratory (systemic) or remote to respiratory tract
ERV	Expiratory reserve volume
ET	Extrathoracic respiratory tract region
f	Respiratory frequency
F	Flux fraction (unitless)
F_r	Fractional deposition
FEL	Frank-effect level
FEV ₁	Forced expiratory volume at one second
fp	Fractional penetration
fp _{ET}	Fractional penetration through the extrathoracic region
fp _{PU}	Fractional penetration through the pulmonary region
fp _{TB}	Fractional penetration through the tracheobronchial region
FRC	Functional residual capacity
FVC	Forced vital capacity
GI	Gastrointestinal
$H_{b/g}$	Blood:gas (air) partition coefficient
H_{EFF}	Effective partition coefficient
$H_{t/b}$	Tissue:blood partition coefficient
$H_{t/g}$	Surface-liquid/tissue:gas (air) partition coefficient

LIST OF ACRONYMS AND ABBREVIATIONS (cont'd)

Ha	Hatta number
HEC	Human equivalent concentration
IC	Inspiratory capacity
iv	Intravenous
k_g	Transport coefficient in the gas phase
K_g	Overall mass transport coefficient
K_{gET}	Overall mass transport coefficient of the extrathoracic region
K_{gPU}	Overall mass transport coefficient of the pulmonary region
K_{gTB}	Overall mass transport coefficient of the tracheobronchial region
k_l	Transport coefficient in the surface-liquid/tissue phase
k_{LG}	Elimination rate from lung compartment
k_m	Alveolar membrane diffusion coefficient
k_r	Reaction rate constant in the blood or tissue
KM	Michaelis constant
L	Airway length
LEL	Lowest-effect level
LOAEL	Lowest-observed-adverse-effect level
LOEL	Lowest-observed-effect level
M_d	Desorbed mass
M_{dET}	Desorbed mass from extrathoracic region to blood
M_{dPU}	Desorbed mass from pulmonary region to blood
M_{dTB}	Desorbed mass from tracheobronchial region to blood

LIST OF ACRONYMS AND ABBREVIATIONS (cont'd)

\dot{M}_{ET}	Mass flux from extrathoracic region to blood
\dot{M}_{PU}	Mass flux from pulmonary region to blood
\dot{M}_{TB}	Mass flux from tracheobronchial region to blood
MF	Modifying factor
MMAD	Mass median aerodynamic diameter
N	Overall transport or flux
N_g	Flux through the air phase
N_l	Flux through the surface liquid-tissue phase
NOAEL	No-observed-adverse-effect level
NOEL	No-observed-effect level
OEL	Occupational exposure level
PEL	Permissible exposure level
PU	Pulmonary respiratory tract region
\dot{Q}_{alv}	Alveolar ventilation rate
\dot{Q}_b	Blood flow rate
\dot{Q}_T	Cardiac output
RGD_r	Regional gas dose to respiratory tract region (r)
RDD_r	Regional deposited dose of particles to respiratory tract region (r)
$RDDR_r$	Regional deposited dose ratio of particles for respiratory tract region (r)
$RGDR_{ET}$	Regional gas dose ratio for the extrathoracic region
$RGDR_{PU}$	Regional gas dose ratio for the pulmonary region
$RGDR_r$	Regional gas dose ratio for respiratory tract region (r)

LIST OF ACRONYMS AND ABBREVIATIONS (cont'd)

$RGDR_{TB}$	Regional gas dose ratio for the tracheobronchial region
RfC	Chronic inhalation reference concentration
RNA	Ribonucleic acid
RV	Residual volume
S_p	Blood perfusion surface area
SA	Surface area of unspecified respiratory region
SA_{ET}	Surface area of the extrathoracic region
SA_{TB}	Surface area of the tracheobronchial region
SA_{PU}	Surface area of the pulmonary region
σ_g	Geometric standard deviation
t	Time
t_{EXH}	Time (duration) of exhalation
TB	Tracheobronchial respiratory tract region
TLC	Total lung capacity
TLV	Threshold limit value
TWA	Time-weighted average
UF	Uncertainty factor
URT	Upper respiratory tract
\dot{V}	Volumetric flow rate
V_b	Capillary blood volume
\dot{V}_E	Minute volume ($V_T \times f$)
V_{LG}	Lung compartment volume

LIST OF ACRONYMS AND ABBREVIATIONS (cont'd)

V_T	Tidal volume
V_{MAX}	Maximum velocity of saturable (Michaelis-Menton) metabolism path
x	Distance into the airway
Δy	Thickness of the surface liquid-tissue layer
z	Distance into the surface-liquid/tissue phase
Δz	Surface-liquid/tissue phase thickness

GLOSSARY

Activity Median Diameter (AMD)

Refers to the median of the distribution of radioactivity, toxicological, or biological activity with respect to particle size.

Acute Exposure

A one-time or short-term exposure with a duration of less than or equal to 24 h.

Aerodynamic Diameter

Term used to describe particles with common inertial properties to avoid the complications associated with the effects of particle size, shape, and physical density.

Aerodynamic Equivalent Diameter (d_{ae})

"Aerodynamic diameter" generally used. The diameter of a unit density sphere ($\rho_p = 1 \text{ g/cm}^3$) having the same settling velocity (due to gravity) as the particle of interest of whatever shape and density. Refer to Raabe (1976) and Appendix H for discussion.

Aerodynamic (Viscous) Resistance Diameter (d_{ar})

The "Lovelace" definition for aerodynamic diameter. Characteristic expression based on terms describing a particle in the Stokes' regime. Refer to Raabe (1976) for equation.

Aerosol

All-inclusive term. A suspension of liquid or solid particles in air.

ATPS

Ambient temperature and pressure, saturated (a condition under which a gas volume is measured).

BTPS

Body temperature and pressure, saturated (a condition under which a gas volume is measured).

Critical Effect

The first adverse effect, or its known precursor, that occurs as the dose rate increases. Designation is based on evaluation of overall data base.

Chronic Exposure

Multiple exposures occurring over an extended period of time, or a significant fraction of the animal's or the individual's lifetime.

Dosimetric Adjustment Factor (DAF)

A multiplicative factor used to adjust observed experimental or epidemiological data to human equivalent concentration for assumed ambient scenario. See regional gas dose ratio (RGDR) and regional deposited dose ratio (RDDR).

Diffusion Diameter

Diameter of a sphere having the same diffusion mobility as the particle in question.

$$d_p < 0.5 \mu\text{m}.$$

Expiratory Reserve Volume (ERV)

The maximum volume exhaled from FRC (FRC – RV).

f Respiratory frequency (breaths/min).

Fr

Fraction of inspired particles deposited in respiratory tract region (r).

Functional Residual Capacity (FRC)

The lung volume at the end of tidal expiration (TLC – IC).

Forced Expiratory Volume (FEV₁) at One Second

The volume of air that can be forcibly exhaled during the first second of expiration following a maximal inspiration.

Forced Vital Capacity (FVC)

The maximal volume of air that can be exhaled as forcibly and rapidly as possible after a maximal inspiration.

Generation

Refers to the branching pattern of the airways. Each division into a major daughter (larger in diameter) and minor daughter airway is termed a generation. Numbering begins with the trachea.

Inhalation Reference Concentration (RfC)

An estimate (with uncertainty spanning perhaps an order of magnitude) of a continuous inhalation exposure to the human population (including sensitive subgroups) that is likely to be without an appreciable risk of deleterious noncancer health effects during a lifetime. The inhalation reference concentration is for continuous inhalation exposures and is appropriately expressed in units of mg/m³.

Inspiratory Capacity (IC)

The maximum inhaled from FRC (TLC – FRC).

Henry's Law Constant

The law can be expressed in several equivalent forms, a convenient form being: $C_g = HC_l$ where C_g and C_l are the gas-(g) and liquid-(l) phase concentrations. The constant (H) is the ratio at equilibrium of the gas phase concentration to the liquid-phase concentration of the gas (i.e., moles per liter in air/moles per liter in solution).

Lowest-Effect Level (LEL)

Same as Lowest-Observed-Adverse-Effect Level.

Lowest-Observed-Adverse-Effect Level (LOAEL)

The lowest exposure level at which there are statistically and biologically significant increases in frequency or severity of adverse effects between the exposed population and its appropriate control group.

Mass Median Aerodynamic Diameter (MMAD)

Mass median of the distribution of mass with respect to aerodynamic diameter. Graphs for these distributions are constructed by plotting frequency against aerodynamic diameters.

Minute Volume (\dot{V}_E)

The volume of air exhaled per minute body temperature and pressure, saturated (BTPS).

Modifying Factor (MF)

An uncertainty factor that is greater than zero and less than or equal to 10; its magnitude reflects professional judgment regarding scientific uncertainties of the data base or study design not explicitly treated by the uncertainty factors (e.g., the number of animals tested). The default value for the MF is 1.

No-Observed-Adverse-Effect Level (NOAEL)

An exposure level at which there are no statistically and biologically significant increases in the frequency or severity of adverse effects between the exposed population and its appropriate control. Some effects may be produced at this level, but they are not considered as adverse, nor immediate precursors to specific adverse effects. In an experiment with several NOAELs, the assessment focus is primarily on the highest one for a given critical effect, leading to the common usage of the term NOAEL as the highest exposure without adverse effect.

Portal-of-Entry Effect

A local effect produced at the tissue or organ of first contact between the biological system and the toxicant.

Regional Deposited Dose (RDD_r)

The deposited dose (mg/cm^2 of respiratory tract region surface area per minute) of particles calculated for the respiratory tract region of interest (r) as related to the observed toxicity (e.g., calculated for the tracheobronchial region for an adverse effect in the conducting airways).

Regional Gas Dose (RGD_r)

The gas dose (mg/cm^2 of respiratory tract surface area per minute) calculated for the respiratory tract region of interest (r) as related to the observed toxicity (e.g., calculated for the tracheobronchial region for an adverse effect in the conducting airways).

Regional Deposited Dose Ratio ($RDDR_r$)

The ratio of the deposited dose in a respiratory tract region (r) for the laboratory animal species of interest (RDD_A) to that of humans (RDD_H). This ratio is used to adjust the observed particulate exposure effect level for interspecies dosimetric differences.

Regional Gas Dose Ratio (RGDR_r)

The ratio of the deposited gas dose in a respiratory tract region (r) for the laboratory animal species of interest to that of humans. This ratio is used to adjust the observed gas exposure level for interspecies dosimetric differences.

Reserve Volume

Volume of air remaining in the lungs after a maximal expiration.

Residual Volume (RV)

The lung volume after maximal expiration (TLC – VC).

Respiratory Bronchiole

Noncartilagenous airway with lumen open along one side to alveoli; when walls are completely alveolarized it is usually referred to as an alveolar duct. Essentially absent in rats.

Stokes' Law

The total drag force or resistance of the medium due to fluid motion relative to the particle is the sum of form and friction drag. When particle motion is described by this equation, it is said to be in the Stokes regime.

Subchronic Exposure

Multiple or continuous exposures occurring for approximately 10% of an experimental species lifetime, usually over 3 mo.

Terminal Bronchiole

Noncartilagenous airway that conducts airstream to respiratory bronchiole.

Threshold

The dose or exposure below which a significant adverse effect is not expected. Carcinogenicity is thought to be a nonthreshold endpoint, thus, no exposure can be presumed to be without some risk of adverse effect. Noncancer toxic health effects are presumed to have threshold endpoints, thus, some exposures are presumed to be without risk of adverse effects.

Tidal Volume (V_T)

Volume of air inhaled/exhaled during normal breathing.

Total Lung Capacity (TLC)

The lung volume at maximal inspiration.

Uncertainty Factor (UF)

One of several, generally 3- to 10-fold factors, used in operationally deriving the inhalation reference concentration (RfC) from experimental data. UFs are intended to account for (1) the variation in sensitivity among the members of the human population, (2) the uncertainty in extrapolating laboratory animal data to humans, (3) the uncertainty in extrapolating from data obtained in a study that is of less-than-lifetime exposure, (4) the uncertainty in using LOAEL data rather than NOAEL data, and (5) the inability of any single study to adequately address all possible adverse outcomes in humans. The RfC methods use 3 for the UF for interspecies extrapolation due to the incorporation of default dosimetric adjustments.

Vital Capacity (VC)

The maximum volume that can be exhaled in a single breath (TLC – RC).

1. INTRODUCTION AND OVERVIEW

This document describes the U.S. Environmental Protection Agency (EPA) methodology for estimation of inhalation reference concentrations (RfCs) (earlier terminology was "inhalation reference dose" or "RfD_i") as benchmark estimates of the quantitative dose-response assessment of chronic noncancer toxicity for individual inhaled chemicals. Noncancer toxicity refers to adverse health effects other than cancer and gene mutations. This overview chapter discusses general principles of dose-response assessment for noncancer toxicity, the development of the RfC methodology, and its role within the context of the risk assessment process. Subsequent chapters of the document discuss criteria and information to be considered in selecting key studies for RfC derivation, provide an overview of the respiratory system and its intra- and interspecies variables, and discuss areas of uncertainty and data gaps in relation to the proposed methodology.

1.1 INHALATION REFERENCE CONCENTRATION: DEVELOPMENT, DEFINITION, AND DERIVATION

The EPA has a history of advocating the evaluation of scientific data and calculation of Acceptable Daily Intake (ADI) values for noncarcinogens as benchmark values for deriving regulatory levels to protect exposed populations from adverse effects. For example, the Office of Pesticide Programs has long used the concept of ADI for tolerance estimates of pesticides in foodstuffs, the Office of Health and Environmental Assessment (OHEA) has used ADI values for characterizing levels of pollutants in ambient waters (Federal Register, 1980), and the National Research Council (1977, 1980) has recommended the ADI approach to characterize levels of pollutants in drinking water with respect to human health.

In 1983, the National Academy of Sciences (NAS) published a report entitled "Risk Assessment in the Federal Government: Managing the Process" (National Research Council, 1983). The NAS had been charged with evaluating the process of risk assessment as performed at the federal level in order to determine the "mechanisms to ensure that government regulation rests on the best available scientific knowledge and to preserve the

integrity of scientific data and judgements" so that controversial decisions regulating chronic health hazards could be avoided. The NAS recommended that the scientific aspects of risk assessment should be explicitly separated from the policy aspects of risk management. Risk assessment, as shown in Figure 1-1, was defined as the characterization of the potential adverse human health effects of exposures to environmental hazards and consists of the following four steps: (1) hazard identification: the determination of whether a chemical is or is not causally linked to a particular health effect; (2) dose-response assessment: the estimation of the relation between the magnitude of exposure and the occurrence of the health effects in question; (3) exposure assessment: the determination of the extent of human exposure; and (4) risk characterization: the description of the nature and often the magnitude of human risk, including attendant uncertainty.

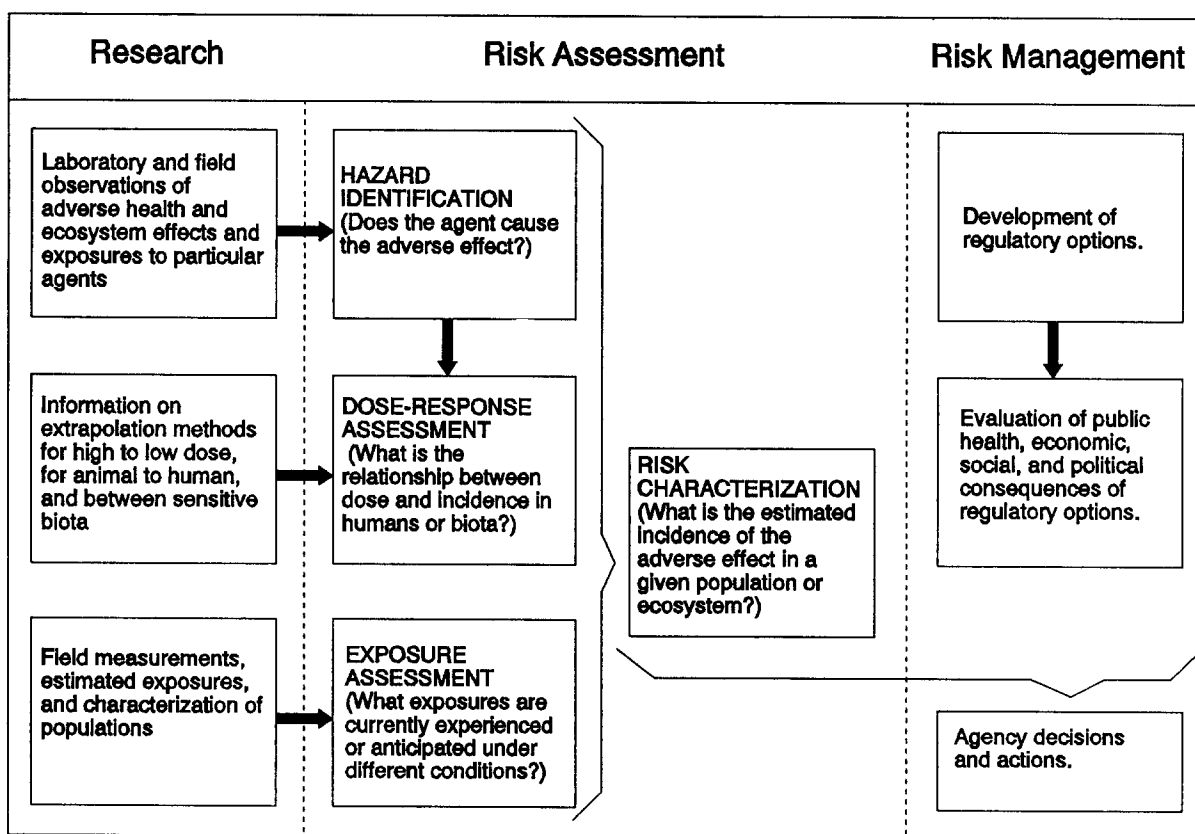

Figure 1-1. National Research Council (1983) framework for risk assessment and risk management. Key elements of each process are shown.

Following the NAS report, the EPA developed a methodology for evaluating available data pertaining to xenobiotics for purposes of developing oral reference doses (RfDs) (Barnes and Dourson, 1988). Although similar to ADIs in intent, RfDs were based upon a more rigorously defined methodology that adhered to the principles proposed by the NAS and included guidance on the consistent application of uncertainty factors for prescribed areas of extrapolation required in the operational derivation. The RfD methodology represents a quantitative approach to assess toxicity data in order to derive a dose-response estimate. According to the NAS paradigm, the final step of the risk assessment process, risk characterization, would involve the comparison of the RfD as a dose-response estimate with an exposure estimate.

The RfC methodology to estimate benchmark values for noncancer toxicity of inhaled chemicals significantly departed from the RfD approach. The same general principles were used, but the RfC methodology was expanded to account for the dynamics of the respiratory system as the portal of entry. The major difference between the two approaches, therefore, is that the RfC methodology includes dosimetric adjustments to account for the species-specific relationships of exposure concentrations to deposited/delivered doses. The physicochemical characteristics of the inhaled agent are considered as key determinants to its interaction with the respiratory tract and ultimate disposition. Particles and gases are treated separately, and the type of toxicity observed (respiratory tract or toxicity remote to the portal-of-entry) influences the dosimetric adjustment applied.

An inhalation reference concentration (RfC) is defined as an estimate (with uncertainty spanning perhaps an order of magnitude) of a continuous inhalation exposure to the human population (including sensitive subgroups) that is likely to be without appreciable risk of deleterious noncancer health effects during a lifetime.

The derivation of any dose-response¹ estimate, such as the RfC, to predict the potential for noncancer toxicity of a chemical requires evaluation of the data array, defined as the toxicity profile of adverse effects observed at the different levels tested among the available

¹Although the strict definitions of "dose", "response", and "effect" are recognized and discussed explicitly in Section 1.2., the conventions of the NAS paradigm will be used in this document, with the RfC being synonymous with a "dose-response" assessment. Therefore, in the broader sense, the term "dose" may encompass administered dose (i.e., exposure concentration), delivered dose, or target tissue dose. Likewise, "response" in the general sense, is an indication of an adverse influence regardless of whether the data were measured as quantal, count, continuous, or ordered categorical.

data. A challenging aspect of this evaluation is that across the available data, often different effects are measured in the same tissue; different endpoints are investigated in some studies; different species are used in various studies; and each investigation may or may not be performed at exposure concentrations that coincide with others. The effects measured may or may not represent different and/or unequivocal degrees of severity or adversity within disease continuums. The dose-response estimate must represent a synthesis of this entire array of data. Therefore, the evaluation of this data array and choice of data on which to base the operational derivation of a dose-response estimate are critical and require somewhat sophisticated toxicological judgment.

In the simplest terms,² the RfC derivation begins with the identification of a no-observed-adverse-effect level (NOAEL) and a lowest-observed-adverse-effect level (LOAEL), which are determined for the specified adverse effect from the exposure levels of a given individual study on the various species tested. The NOAEL is the highest level tested at which the specified adverse effect is not produced and is therefore, by definition, a subthreshold level (Klaassen, 1986). This NOAEL/LOAEL approach, is also a function of the exposure levels used in the experimental design or is the function of designating a specified health effect measure (e.g., 10% incidence of a lesion) in the case of some alternative modeling approaches, and thus, does not necessarily reflect the "true" biological threshold.

The RfC methodology requires conversion by dosimetric adjustment of the NOAELs and LOAELs observed in laboratory animal experiments or in human epidemiological or occupational studies to human equivalent concentrations (HECs) for ambient exposure conditions. These conditions are currently assumed to be 24 h/day for a lifetime of 70 years. The dosimetric conversion to an HEC is necessary before the different adverse effects in the data array can be evaluated and compared.

Definition of an HEC may be viewed as a naive presumption. However, because the methodology acknowledges that accurate dose-response relationships depend on the degree to which state-of-the-art research has achieved understanding and characterization of the

²As discussed in Appendix A, there are alternative approaches under development aimed at deriving estimates of exposures that are analogous in intent to the establishment of a NOAEL. The NOAEL/LOAEL approach outlined here is not intended to discourage alternative or more sophisticated dose-response procedures when sufficient data are available, but rather to present key issues involved in any approach for the assessment of noncancer toxicity.

exposure-dose-response continuum and will therefore be revised accordingly, it must be recognized that the definition of HEC is iterative and dynamic as well. That is, the HEC is a concentration back-extrapolated from an appropriate surrogate internal dose to the extent that this has been defined.

Although it is preferable to use human studies as the basis for the dose-response derivation, adequate human data are not always available, often forcing reliance on laboratory animal data. Presented with data from several animal studies, the risk assessor first seeks to identify the animal model that is most relevant to humans, based on comparability of biological effects using the most defensible biological rationale; for instance, by using comparative metabolic, pharmacokinetic, and pharmacodynamic data. In the absence of a clearly most relevant species, however, the most sensitive species is used as a matter of science policy at the EPA. For RfCs, the most sensitive species is designated as the species that shows the critical adverse effect at an exposure level that, when dosimetrically adjusted, results in the lowest HEC.

The critical toxic effect used in the dose-response assessment is generally characterized by the lowest $\text{NOAEL}_{[\text{HEC}]}$ that is also representative of the threshold region (the region where toxicity is apparent from the available data) for the data array. The objective is to select a prominent toxic effect that is pertinent to the chemical's key mechanism of action. This approach is based, in part, on the assumption that if the critical toxic effect is prevented, then all toxic effects are prevented (see Section 1.2, general principles of dose-response assessment for noncancer toxicity). The determination of the critical toxic effect from all effects in the data array requires toxicologic judgment because a chemical may elicit more than one toxic effect (endpoint) in tests of the same or different exposure duration, even in one test species. Further, as discussed in Appendix A, the NOAEL and LOAEL obtained from studies depend on the number of animals or subjects examined and on the spacing of the exposure levels. The $\text{NOAEL}_{[\text{HEC}]}$ from an individual study (or studies) that is also representative of the threshold region for the overall data array is the key datum synthesized from an evaluation of the dose-response data. Determination of this critical effect represents the first scientific evaluation required by the RfC dose-response assessment.

The RfC is an estimate that is derived from the $\text{NOAEL}_{[\text{HEC}]}$ for the critical effect by consistent application of uncertainty factors (UFs). The UFs are applied to account for

recognized uncertainties in the extrapolations from the experimental data conditions to an estimate appropriate to the assumed human scenario. Determination of which UFs to apply and the magnitude of each represents the second scientific evaluation required by an RfC dose-response assessment. The standard UFs applied are those for the following extrapolations (as required): (1) effects in average healthy humans to sensitive humans, (2) laboratory animal data to humans, (3) studies of subchronic to chronic duration, (4) a LOAEL_[HEC] to a NOAEL_[HEC], and (5) an incomplete to complete data base. The UFs are generally an order of magnitude, although incorporation of dosimetry adjustments or other mechanistic data has routinely resulted in the use of reduced UFs for RfCs. The typical reduced UF is three or one-half log₁₀ (i.e., 10⁻⁵). The composite UF applied to an RfC will vary in magnitude depending on the number of extrapolations required. An RfC will not be derived when use of the data involve greater than four areas of extrapolation. The composite UF when four factors are used is generally reduced from 10,000 to 3,000 in recognition of the lack of independence of these factors. An additional modifying factor (MF) may also be applied when scientific uncertainties in the study chosen for operational derivation are not explicitly addressed by the standard UFs. For example, an MF might be applied to account for a statistically minimal or inadequate sample size or for poor exposure characterization.

Thus, notationally, the RfC is defined as

$$\text{RfC} = \text{NOAEL}^*_{[\text{HEC}]} / (\text{UF} \times \text{MF}), \quad (1-1)$$

where:

NOAEL^{*}_[HEC] = The NOAEL or analogous effect level obtained with an alternate approach as described in Appendix A, dosimetrically adjusted to a human equivalent concentration (HEC);

UF = Uncertainty factor(s) applied to account for the extrapolations required from the characteristics of the experimental regimen; and

MF = Modifying factor to account for scientific uncertainties in the study chosen as the basis for the operational derivation.

Confidence levels of high, medium, or low are assigned to the study used in the operational derivation, to the overall data base, and to the RfC itself. Confidence ascribed to the RfC estimate is a function of both the confidence in the quality of the study and confidence in the completeness of the supporting data base together, with the data base confidence taking precedence over that assigned to the study. High confidence in the RfC is an indication that the data base included investigation of a comprehensive array of noncancer toxicity endpoints established from studies of chronic duration in various mammalian species and that the study (or studies) established an unequivocal NOAEL. Therefore, a high confidence RfC is not likely to change substantially as more data become available, with the exception of additional mechanistic data or sophisticated tests that may change the perspective of the evaluation. Low confidence in an RfC is usually applied to a derivation that is based on several extrapolations and indicates an estimate that may be especially vulnerable to change if additional data become available. For some chemicals, the data base is so weak that the derivation of a low confidence RfC is not possible (see Section 4.1 for minimum data base criteria). In such cases, the data base supporting an RfC for a chemical is designated as "not-verifiable". Upon the availability of new data, this not-verifiable status would be reevaluated.

It must be emphasized that the RfC as a quantitative dose-response estimate is not numeric alone. As risk assessments have become a more prevalent basis for decision-making, their scientific quality and clarity of presentation have gained unprecedented importance (American Industrial Health Council, 1989). Due to the complexity of many risk assessments, desirable attributes include the explicit treatment of all relevant information and the expression of uncertainty in each element (i.e., hazard identification, dose-response assessment, exposure assessment, risk characterization). Any dose-response assessment, such as the RfC, has inherent uncertainty and imprecision because the process requires some subjective scientific judgment, use of default assumptions, and data extrapolations. A complete dose-response evaluation should include communication of the rationale for data selection, the strengths and weaknesses of the data base, key assumptions, and resultant uncertainties (Habicht, 1992; American Industrial Health Council, 1989, 1992; U.S. Environmental Protection Agency, 1984a). The rationale for the choice of the data from which the RfC is derived, a discussion of data gaps, and the resultant confidence in the

RfC are all outlined in the summary of the RfC entered on the EPA's Integrated Risk Information System (IRIS). A discussion and rationale for the UFs used in the RfC derivation are also provided. This information is an important part of the RfC and must be considered when evaluating the RfC as a dose-response estimate, in addition to assumptions and resultant uncertainties inherent in an exposure assessment, when attempting to integrate the assessments into a risk characterization.

In summary, the RfC methods presented herein were developed based on the NAS 1983 framework and are in keeping with the recent NAS report on science and judgement in risk assessment (National Research Council, 1994). Default options for derivation of NOAELs and LOAELs and for dosimetric adjustments of particle or gas exposures are presented. Principles for modifying and departing from these default options are also provided. The methods represent the currently available science. Uncertainty factors are utilized that allow for RfC derivation in the absence of some data, but the UF and confidence statements explicitly call out prescribed areas of extrapolation in order to communicate data gaps. For example, a UF is used to account for intraindividual variability, an area identified by the NAS as one requiring additional data to more accurately characterize susceptibility of subpopulations.

1.2 GENERAL PRINCIPLES OF DOSE-RESPONSE ASSESSMENT FOR NONCANCER TOXICITY

Noncancer toxicity refers to adverse health effects or toxic endpoints, other than cancer and gene mutations, that are due to the effects of environmental agents on the structure or function of various organ systems. These effects include those on the tissue where the chemical enters the body, such as the respiratory tract for inhaled agents, and also effects that follow absorption and distribution of the toxicant to a site remote to its entry point. Most chemicals that produce noncancer toxicity do not cause a similar degree of toxicity in all organs, but usually demonstrate major toxicity to one or two organs. These are referred to as the target organs of toxicity for that chemical.

Empirical observation generally reveals that as the dose of a toxicant is increased, the toxic response also increases. "Response", in the context of the RfC methodology discussion

may be the degree or severity of an effect in an individual or the fraction of a population responding. A distinction is sometimes made between response and effect as different measurements. Effects are graded and measured; whereas responses are quantal and counted (O'Flaherty, 1981). The distinction is necessary in order to determine an appropriate mathematical or statistical model for analysis. For dichotomous responses, model estimates describe probabilities of events in individuals. These probabilities can also be thought of as the fraction of a population that will show the response. For continuous effects, models estimate expected changes in individuals. These expected changes can be expressed as shifts in population means. For practical and sound conceptual reasons, responses and effects can be considered to be identical (Klaassen, 1986). That is, in a qualitative sense when trying to ascertain if a toxic agent exerts an adverse influence, the distinction is unimportant. It is recognized that the distinction must be carefully applied when employing mathematical models to calculate estimates.

The importance of understanding the relationship between concentration (applied dose) and response has been established in the theory and practice of toxicology and pharmacology. Dose-response behavior is exemplified by the following types of data: (1) quantal responses (dichotomous), in which the number of responding individuals in a population increases as a function of dose (e.g., number of animals with a specified effect at each exposure concentration); (2) count responses, in which the number of measured events increases as dose is increased (e.g., number of lesion foci in tissue); (3) dose-graded responses (ordered categorical), in which the severity of the toxic response within an individual or system increases with dose (e.g., pathology graded from mild to severe); and (4) continuous responses, in which changes in a biological parameter (e.g., organ weight, nerve conduction velocity) vary with dose.

Classic toxicology texts and the NAS framework for risk assessment refer to dose-response assessment as the process of estimating an expected response at various exposure levels (i.e., the response at various applied dose levels or exposure concentrations). Because tissue dose of the putative toxic moiety for a given response is not always proportional to the applied dose of a compound, emphasis has recently been placed on the need to clearly distinguish between exposure concentration and dose to critical target tissues. The term "exposure-dose-response assessment" has been recommended as more accurate and

comprehensive (Andersen et al., 1992). This expression refers not only to the determination of the quantitative relationship between exposure concentrations and target tissue dose, but also to the relationship between tissue dose and the observed/expected responses in laboratory animals and humans.

As shown in Figure 1-2, the process of determining the exposure-dose-response continuum is achieved by linking the mechanisms or critical biological factors that regulate the occurrence of a particular process and the nature of the interrelationships among these factors (Andersen et al., 1992). Although the mechanisms of interaction at the molecular level are very different from the mechanisms involved at the population level, in each case they refer to biological determinants that control the responses at the respective level of organization. This figure illustrates that the exposure-dose-response continuum evolves from protective to predictive as more information becomes available on mechanisms and toxic events. Dose-response assessment estimates based on characterization at the first "black box" level necessarily incorporate large uncertainty factors to ensure that the estimates are protective in the presence of data gaps, which are often substantial. With each progressive level, incorporation and integration of mechanistic determinants allow elucidation of the exposure-dose-response continuum and thus, a more accurate characterization of the pathogenesis process. Although utilization of these data reduces uncertainty in the dose-response assessment (thus allowing it to be more predictive in nature), in reality, there will always be some degree of uncertainty.

As this comprehensive continuum is characterized, mechanistic determinants of chemical disposition, toxicant-target interactions, and tissue responses are integrated into an overall model of pathogenesis. The three proposed stages in the continuum between exposure and response are similar to the previously described division of "pharmacokinetics" versus "pharmacodynamics". Pharmacokinetics was defined to encompass processes relating exposure to consequent tissue doses, whereas pharmacodynamics encompassed processes that determined response to the tissue dose. This comparison to the two traditional areas of investigation is offered only as a context for the new terminology because any divisions are artificial and a reflection of the degree of understanding of events in the pathogenesis process.

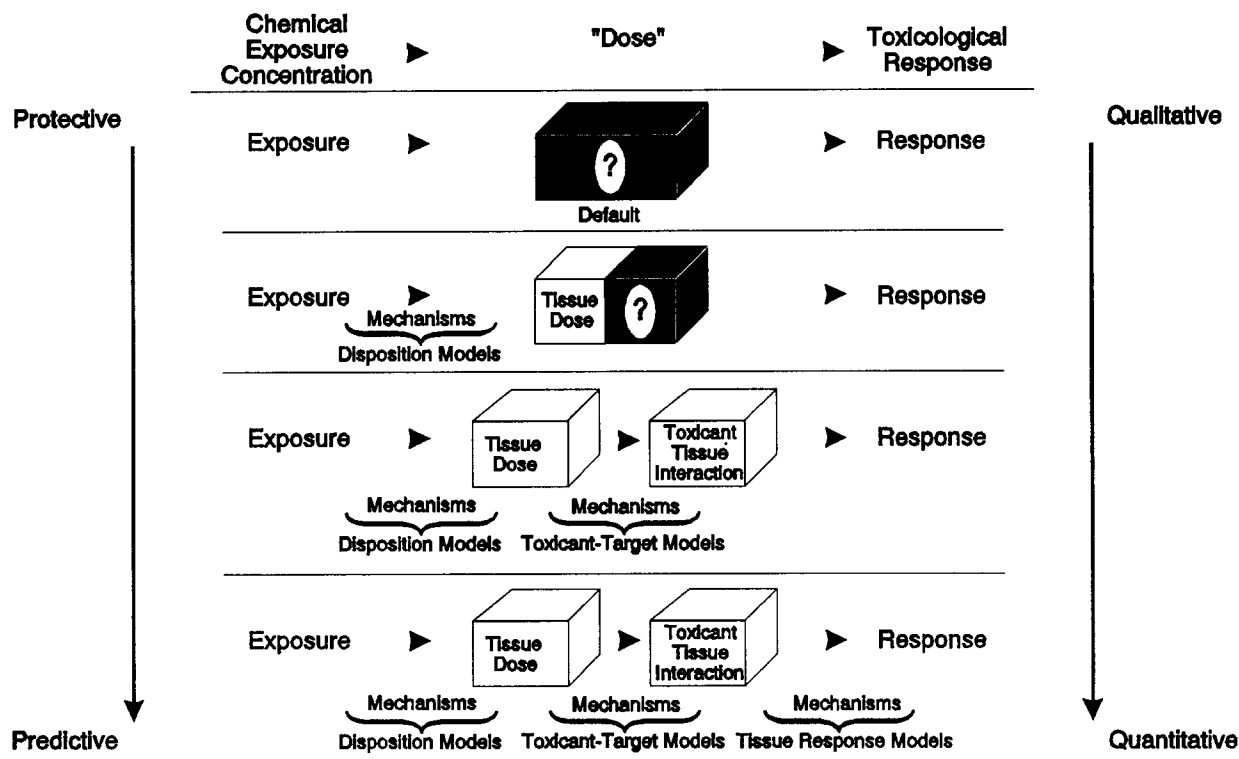

Figure 1-2. Schematic characterization of comprehensive exposure-dose-response continuum and the evolution of protective to predictive dose-response estimates.

Adapted from Conolly (1990) and Andersen et al. (1992).

Disposition includes deposition, absorption, distribution, metabolism, and elimination of chemicals. Mathematical models of the mechanistic determinants of the disposition of a parent compound and/or its metabolites, such as physiologically based pharmacokinetic (PBPK) or dosimetry models, have been useful in describing the relationships between exposure concentration and target tissue dose (Overton, 1984; Andersen et al., 1987a). These disposition models can be linked to other models that address the mechanistic determinants of the toxicant-target tissue interaction and tissue response, respectively. These latter models refine the designation of response. The tissue dose is linked to determinants of target-tissue interaction, (e.g., critical mechanistic events such as cytotoxicity and rebound

cellular proliferation), which, in turn, may then be related via other mechanisms to the ultimate production of lesions or functional changes that are typically defined as the disease (pathogenesis) outcome. To the extent that these events are explanatory of the disease outcome, they can be used to quantitate important nonproportionalities or as replacement indices of the response function. It is important to emphasize that the integration of the mechanistic determinants may not necessarily be achieved by linking respective models in a series (i.e., the output of one model becomes input to the next) but may require simultaneous solution (e.g., the mechanistic determinants of disposition are dynamically related "moment-by-moment" to mechanisms of toxicant-target interaction). Eventually, causality of the critical mechanistic toxic effect can be correlated to the internal toxic moiety as the dose surrogate, rather than relating the exposure concentration to the "black box" of the organism within a population. It should also be recognized that the history of toxicology shows that the discovery of a mechanism of toxicity is often accompanied by the identification of a new or more refined uncertainty. In spite of such knowledge dynamics, expanding the envelope of "knowns" clearly improves quantitative dose-response assessment, while creating more challenges to continue to define unknowns.

Predictive dose-response estimates are desired in order to increase the accuracy of the estimates and eliminate attendant uncertainties. An advantage to the iterative process of characterizing the exposure-dose-response continuum is that the models used to describe the pathogenesis process are dynamic and can be updated by additional data and/or changes in understanding of the process. As will be seen in later chapters, dosimetry and PBPK models not only are considered the optimal approach for extrapolation of dose across species, but also have provided insight on important mechanistic determinants that have been utilized in the default dosimetry adjustments applied to RfC derivation.

Since the dosimetric adjustments incorporate mechanistic determinants of disposition, they can be applied, after consideration of underlying assumptions described herein, to adjustment of other inhalation exposures (e.g., acute exposures) or toxicity (e.g., cancer). The framework evaluating alternative model structures would also be applicable.

Although RfCs are expressed as exposure concentrations so that units are comparable to those of exposure assessment estimates, it must be emphasized that the RfC exposure concentrations are back-extrapolated and based on target tissue dose and/or critical

mechanistic effects, to the extent possible. As more data become available and understanding of the pathogenesis process changes, changes in the dose-response estimate are anticipated.

Generally, based on understanding homeostatic and adaptive mechanisms, most dose-response assessment procedures operationally approach noncancer health effects as though there is an identifiable threshold (both for the individual and for the population) below which effects are not observable. However, it is recognized that there are inherent difficulties in the identification of population thresholds (Gaylor, 1985). For example, although each National Ambient Air Quality Standard (NAAQS) is based on noncancer toxicity, not one is based on a threshold. This is likely the result of the extensive nature of the data base and the investigation of the effects in identified sensitive subpopulations that support each of the NAAQS. That is, the operational identification of a threshold is a function of the available data and current understanding of the exposure-dose-response continuum, which may be revised as more information such as data from studies encompassing additional endpoints or more sensitive indicators of toxicity, such as mechanistic determinants, are developed and evaluated.

For an individual, the threshold concept presumes that a range of exposures from zero to some finite value can be tolerated by the organism without adverse effects. As an example, there could be a large number of cells that perform the same or similar function whose population must be significantly depleted before an adverse effect is seen. This threshold will vary from one individual to another, so that there will be a distribution of thresholds in the population. Because sensitive subpopulations (i.e., those individuals with low thresholds) are frequently of concern in setting exposure standards, risk-assessment efforts are aimed at estimating levels at which these sensitive individuals would not be expected to respond.

The identification of a threshold currently distinguishes approaches for noncancer toxicity assessment from those for carcinogenic endpoints, which dose-response assessment procedures typically approach as resulting from nonthreshold processes. However, it should be noted that as the exposure-dose-response continuum described above is characterized better for both certain carcinogens and noncarcinogens, knowledge of the mechanistic determinants may blur this distinction between approaches for noncancer toxicity and carcinogenicity. As mentioned above, consideration of dosimetry determinants are applicable regardless of

toxicity endpoint. The EPA guidelines for cancer assessment are undergoing revision, and an issue under review is how to incorporate mechanistic data (Federal Register, 1988a).

1.3 GUIDELINES ON SPECIFIC ENDPOINTS

As mentioned, one of the major challenges to performing dose-response assessment for noncancer endpoints is that it requires the evaluation of effects measured in a number of different tissues. Often different endpoints are investigated in different studies, in different species, and at various concentrations. The effects measured may represent different degrees of severity or adversity within disease continuums. Individual studies must be evaluated for their usefulness for quantitative assessment, which will be discussed in Chapter 2. The available information then must be synthesized into an assessment of the dose-response for noncancer toxicity based on the entire array of data. The overall data array analysis and integration of data are a critical aspect of the RfC methodology and are discussed in Chapter 4 (Section 4.3.7).

In order to promote technical quality and consistency in risk assessment, guidelines have been developed on how to evaluate toxicity data for cancer and a number of different noncancer endpoints, how to evaluate mixtures (U.S. Environmental Protection Agency, 1987), and how to perform an exposure assessment (Federal Register, 1992a). Guidelines have also been promulgated for the evaluation of developmental toxicity (Federal Register, 1991) and proposed for the evaluation of female and male reproductive toxicity (Federal Register, 1988b,c). Guidelines under development for other noncancer endpoints include those for neurotoxicity, immunotoxicity, and respiratory tract effects.

The historical and conceptual development of the guidelines and their role in the EPA have been discussed elsewhere (U.S. Environmental Protection Agency, 1987; Jarabek and Farland, 1990). Within the context of the RfC methodology, these guidelines present key considerations and approaches to the evaluation of data within an individual endpoint to arrive at a dose-response estimate. Therefore, the RfC methodology will look to the guidelines on individual endpoints for ways to consider the data, organize the data, and conduct a dose-response assessment. The RfC methodology then provides guidance on how to approach the

synthesis of the resultant dose-response estimate with estimates for other noncancer endpoints to arrive at an overall dose-response estimate for the data array.

1.4 USE OF THE INHALATION REFERENCE CONCENTRATION IN THE NATIONAL ACADEMY OF SCIENCES RISK ASSESSMENT AND RISK MANAGEMENT PARADIGM

As discussed earlier, the 1983 NAS report on risk assessment in the federal government recommended that the scientific aspects of risk assessment should be explicitly separated from the policy aspects of risk management. The RfC approach described here represents one component of the risk assessment process, the dose-response component, and as such must be compared against an exposure estimate in order to characterize risk. The attendant uncertainties and default assumptions of the RfC estimate should be evaluated in context with those of the exposure estimate (e.g., averaging time of the measured exposure, exposure pattern, particle size) to ascertain whether the two are appropriate to integrate. The explicit treatment of all such relevant information and resultant uncertainties is a requisite for any final risk characterization. One of the uncertainties that needs to be considered when comparing an RfC to an exposure estimate is the "order-of-magnitude" imprecision of the RfC itself, as stated in the definition of the RfC. From a purely mathematical viewpoint, this refers to a \log_{10} around the RfC (i.e., 3-fold above and below). However, such uncertainty is not purely mathematical, but rather is an expression of the difficulty in translating a data base (which is often very limited) into a single number that is thought to represent a relatively safe exposure. This discussion is not intended to be a complete presentation on the use of RfCs. Rather, it expresses a few of the issues that require consideration and illustrates that simplistic comparisons of one dose-response value to one exposure value may be inadequate to precisely represent risk characterization.

The EPA recognizes that regional, state, and local health protection departments need uniform and scientifically sound procedures for the calculation of benchmark inhalation dose-response estimates. The proliferation of diverse risk assessment values for inhalation exposure and the resulting confusion this has caused attests to the importance of a consistent approach. It is the intention of the EPA that the RfC approach described will be useful to many in performing dose-response assessments as one piece of the risk assessment process.

1.5 OCCUPATIONAL EXPOSURE LIMITS VERSUS INHALATION REFERENCE CONCENTRATIONS

Occupational exposure limit (OEL) is a generic term used to denote a variety of standards that usually reflect a documented body of toxicological, epidemiological, and clinical information pertaining to human exposure to airborne contaminants. Due to their derivation methods, attendant assumptions, and intended application, they represent risk management values, and this distinction with the RfC as a dose-response estimate must be emphasized.

Occupational exposure limits have often been chosen by organizations for their risk management programs because they are available for nearly 700 pollutants. The OELs include the Occupational Safety and Health Administration Permissible Exposure Limits (PELs) or full text standards, the National Institute of Occupational Safety and Health Recommended Standards, and the American Conference of Governmental Industrial Hygienists (ACGIH) threshold limit values (TLVs). The OELs differ among themselves in regard to the philosophy of the sponsoring organization, legal mandate, objectives, assumptions, and evaluation of scientific data. They share the common elements of the evaluation of effects due to inhalation exposure and the goal of protection of human health.

The OELs are generally time-weighted average concentrations of airborne substances to which a healthy worker can be exposed during defined work periods and under specific work conditions throughout a working lifetime, without material impairment of health.

An important underlying assumption of most OELs is a workplace setting in which industrial hygienists are able to control the environments. Therefore, the OEL can represent, in part, a risk management decision that considers nonhealth issues such as the technological feasibility of control measures and analytical detection limits. Some OELs, such as the ACGIH TLV, also reflect the cost of controlling exposure levels. The appropriateness of some of these assumptions and extenuating considerations to the application of deriving ambient air levels for pollution control have been discussed elsewhere (Jarabek and Segal, 1994).

A number of these same assumptions and considerations preclude the use of OELs directly for the derivation of RfCs. The OELs often are not based on chronic effects and may differ from RfCs in severity of effect. The OELs further assume intermittent exposure periods of the workplace, whereas RfCs are set to protect against continuous exposure. The

OELs may not incorporate the most current toxicological information because toxicological review is not on a regular basis. Also, the unavailability of unpublished corporate documentation precludes scientific scrutiny of the primary basis for a number of TLVs (Castleman and Ziem, 1988). The evaluation of toxicity data by agencies deriving OELs may differ from that of EPA with respect to weight-of-evidence classification, application of UFs, and other issues. Finally, the use of OELs is established to protect the average healthy worker (ages 18 to 65 years) against the adverse effects of inhaled pollutants to which they are exposed only a fraction of a day (i.e., during a typical 8-h work shift). Inhalation reference concentrations, however, are relevant to those of any age and health status and are aimed at protecting the most sensitive members of the population, assuming long-term continuous exposures. Therefore, the EPA does not endorse the use of OELs in deriving RfCs. The OEL data base should be evaluated along with all other data according to the methodology for RfC derivation. The biological endpoint, quality and nature of the underlying data sets, the exposure scenarios, and applicability to highly sensitive subpopulations are among those factors that must be considered for relevance to nonoccupational exposures.

An issue paper on OEL values, developed by the Inhalation Technical Panel of EPA's Risk Assessment Forum, discusses the history, use, and limitations of OELs as surrogates for ambient exposure RfC values (U.S. Environmental Protection Agency, 1990).

1.6 PRIMARY NATIONAL AMBIENT AIR QUALITY STANDARDS VERSUS INHALATION REFERENCE CONCENTRATIONS

The Clean Air Act requires that NAAQS be set for any ubiquitous air pollutant that, if present in the air, may reasonably be anticipated to endanger the public health or welfare and whose presence in the air results from numerous or diverse mobile or stationary sources. These so-designated pollutants are called criteria pollutants. Primary standards are designed to protect public health, and secondary standards are designed to protect public welfare (Code of Federal Regulations, 1991). The primary NAAQS are solely health-based and designed to protect the most sensitive group of individuals (but not necessarily the most sensitive members of that group) against adverse health effects. Therefore, by definition, the primary

NAAQS define allowable pollutant concentrations that can be present in the atmosphere without causing adverse health effects and represent a complete health risk characterization according to the NAS risk assessment and risk management paradigm.

This RfC methodology will not be applied to the criteria air pollutants (carbon monoxide, lead, ozone, nitrogen dioxide, particulate matter, and sulfur dioxide) due to legislative requirements in the Clean Air Act and major differences in the health data bases of these pollutants. Development of NAAQS for the criteria pollutants is governed by Sections 108 and 109 of the Clean Air Act. The health assessment is described more fully elsewhere (Padgett and Richmond, 1983) and essentially is a scientific process that undergoes extensive review by the public and the Clean Air Scientific Advisory Committee of EPA's Science Advisory Board. The determination of adversity and identification of a NAAQS with an adequate margin of safety is a decision reserved to the EPA Administrator by the Clean Air Act. This is profoundly different from an RfC in which the determination of adversity and uncertainty factors are part of the scientific assessment itself. Furthermore, the criteria air pollutants have extensive health data bases that enable avoiding many of the simplifying assumptions and default procedures of the RfC methodology. For additional details, refer to the Code of Federal Regulations (1991a), criteria documents for these chemicals (U.S. Environmental Protection Agency, 1982a,b,c; 1984b,c; 1986a,b,c,d; 1991; 1992; 1993a,b), and an overview article describing the NAAQS development process (Padgett and Richmond, 1983).

1.7 STATE-OF-THE-ART APPLICATIONS TO THE DEVELOPMENT OF THE INHALATION REFERENCE CONCENTRATION METHODOLOGY

All elements of risk assessment (i.e., hazard identification, dose-response assessment, exposure assessment, risk characterization) involve some degree of reliance upon assumptions or extrapolations that substitute for unavailable quantitative information and, by that, impart varying degrees of uncertainty. Risk assessments ultimately serve as the basis for personal or governmental risk management decisions on safeguarding health and have consequential economic impacts. As the state-of-the-art of health risk science progresses, the accuracy of risk assessments will be improved, insofar as these advancements are incorporated into risk

assessment procedures. This makes it imperative that, as scientific advancements in related disciplines such as biologically motivated extrapolation modeling are made, they are appropriately incorporated into the elements of the risk assessment process. The RfC methodology, as a set of procedures to estimate a dose-response assessment, has inherent uncertainty and imprecision because the process requires some subjective scientific judgment, use of default assumptions, and data extrapolations. Therefore, OHEA, Office of Research and Development, has committed to a regular reevaluation of the scientific advancements in the field and will continue to make recommendations for significant improvements in the methodology. Modifications are anticipated on approximately a 2-year basis or as appropriate. If research advancements having a striking impact on the methodology were to occur earlier or slightly later, the timing of the process may be altered.

In summary, one objective of the RfC methodology is that it always be scientifically based, and thus, the methodology should be considered dynamic. Pertinent issues and their solutions will be incorporated as identified and reviewed for applicability on a continuing basis. These actions will make the methodology sufficiently reliable to serve as one of the key bases for decisions on protecting the public health.

2. QUALITATIVE EVALUATION OF THE DATA BASE

This chapter outlines considerations for the collection and qualitative evaluation of diverse data into a cohesive toxicity profile that then can be evaluated by means of the quantitative procedures for dose-response analysis provided in Chapter 4. The conceptual basis for the dosimetry adjustments applied to inhaled agents and other considerations specific to this administration route are addressed in Chapter 3.

The aim of the inhalation reference concentration (RfC) methodology is to establish a relationship between a particular agent in the air and a specific health effect (or effects). To define such a relationship, evidence must be collected from diverse sources and synthesized into an overall judgment of health hazard (Hackney and Linn, 1979). One of the major challenges to performing dose-response assessment for noncancer endpoints is that it requires the evaluation of effects measured in a number of different tissues. Often different endpoints are investigated in different studies, in different species, and at various concentrations. The effects measured may represent different degrees of severity (adversity) within disease continuums. Qualitative evaluation of the data base, also known as the hazard identification component of risk assessment, involves integrating a diverse array of data into a cohesive, biologically plausible toxicity "picture" or weight-of-the-evidence relationship to establish that the agent causes an effect (or effects) and is of potential human hazard. Questions addressed by this process include whether the agent associated with an effect is responsible for the effect, if the effect is biologically significant, and what the potential public health implications might be. Answering such questions requires ascertaining the validity and meaning of the toxicity data, determining whether the experimental results as a whole suggest or show causality between the agent and the effect, and evaluating whether or not the causal relationship is applicable under other sets of circumstances (e.g., in extrapolating from test animals to humans). This entails consideration of all relevant human and laboratory animal data of various study types, studies with differing results (e.g., positive and negative), pharmacokinetic disposition data (deposition, absorption, distribution, metabolism, elimination) mechanistic information, and structure-activity relationships. This process integrates information needed for the dose-response assessment, which is discussed in

Chapter 4. Thus, qualitative evaluation of a diverse data base necessitates a systematic approach for obtaining agreement on the validity, selection, and interpretation of studies to be used in the quantitative methodological procedures of the dose-response assessment.

2.1 GUIDELINES FOR SELECTIONS OF KEY STUDIES

Key studies are those that contribute most significantly to the weight of evidence as to whether or not a particular chemical is potentially hazardous in humans (Barnes and Dourson, 1988). These studies are of two types: (1) epidemiologic, clinical, or case reports on humans and (2) experimental studies on animals. Each has unique considerations that will be addressed separately here. However, whenever the data base permits, the most robust qualitative evaluation typically involves an integrated interpretation of human and animal data, taking advantage of the unique strengths of each. Once the key studies demonstrating the critical toxic effect have been identified, the selection of effect level and the RfC derivation arises from an objective scientific evaluation of the data array available on the chemical as described in Chapter 4.

2.1.1 Human Data

Utilization of human data avoids the necessity of extrapolating from laboratory animals to humans, thereby decreasing uncertainty in the risk assessment. Human data have often been useful in developing oral reference doses (RfDs) (Barnes and Dourson, 1988). There are significantly more human data on inhalation than on ingestion exposures, however, so that criteria for evaluating studies and their results need to be stated explicitly, particularly if they are to be used in a quantitative fashion. Since 1977, when the Clean Air Act identified goals related to air quality and health, the task of clarifying how population studies can be used for determining scientifically reasonable standards and how to define an adverse respiratory health effect has been rigorously debated (Lebowitz, 1983; American Thoracic Society, 1985; National Research Council, 1985). Many of the results from these efforts can be applied as guidance for the RfC methodology.

Three types of human studies are most often utilized to obtain data pertinent to understanding the risk of chemicals to humans in order to protect public health:

(1) epidemiologic studies, (2) clinical studies or controlled exposure experiments, and (3) case reports. In addition, recent advances in molecular epidemiology and physiologically based pharmacokinetic (PBPK) simulation modeling provide other types of data useful to evaluating and synthesizing data from these three types of human studies along with laboratory animal data. When using these studies for risk assessment, several factors are important in evaluating their quality and in determining the level of certainty associated with their use. The factors that are most relevant to developing chronic RfCs from human data relate to biomarkers and epidemiologic studies, which are discussed more fully below. Clinical studies are typically of acute or short durations and therefore, as such, are less useful as the basis of an RfC, but can be useful in the development of dosimetric data relevant to biomarkers.

2.1.1.1 Molecular Epidemiology and Biologic Markers

In the early 1980s, the concept of "molecular epidemiology" was developed to describe an evolving approach to research that attempts to synthesize advanced laboratory methods with analytical epidemiology (Perera and Weinstein, 1982). Although originally defined for cancer, molecular epidemiology can encompass any disease outcome and can provide important insights and understanding of a wide variety of critical issues in current risk assessment (Hattis, 1986). The approach is based on the combination of two biologic tenets: (1) early biologic effects from a toxic exposure are far more prevalent in the population at risk than the late events of direct (historical) interest such as disease, and may sometimes be more specific to the exposure than the outcome itself; and (2) given technological advances, most xenobiotics can either be directly quantified in the body or indirectly measured by identification of some predictable, dose-related biologic response (Cullen, 1989). Thus, once (prevalent, early) "markers" of effect and (accurate) "markers" of dose can be developed in the laboratory, human epidemiology could, with appropriate research, proceed without its prior methodologic constraints; relative risks are high because the events studied are either very common among the exposed (i.e., sensitive markers) or very rare among the unexposed (i.e., specific markers); exposures can be precisely classified by direct measurement and the lapsed time between first human exposure and an opportunity for study is foreshortened because endpoints are, by definition, "early" (Cullen, 1989).

Biologic markers are not new. Markers such as blood lead, mercury levels in hair, and urinary metabolites or liver function assays after solvent exposure have long been used in health research and practice to indicate exposures to or to predict effects of these compounds. As defined by the National Research Council (NRC) Board on Environmental Studies and Toxicology, a "biologic marker" is any cellular or molecular indicator of toxic exposure, adverse health effects, or susceptibility (National Research Council, 1987). The markers may represent signals—generally biochemical, molecular, genetic, immunologic, or physiologic—in a continuum of events between a causal exposure and resultant disease as shown in Figure 2-1.

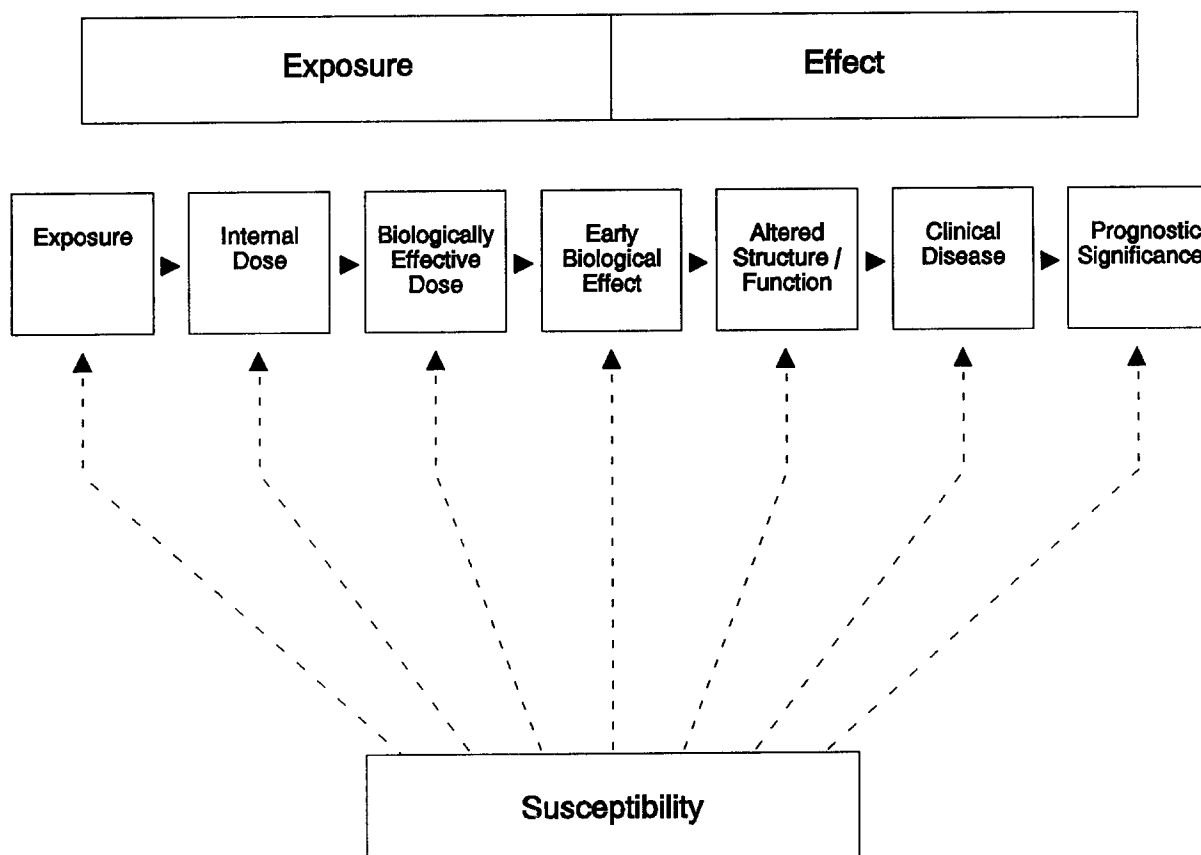

Figure 2-1. Biological marker components in sequential progression between exposure and disease.

Source: Schulte (1989).

The distinguishing aspect of this paradigm vis-à-vis the previous use of biological markers is that current technological advances and developments in basic sciences allow for detection of smaller signals at diverse points in the continuum. Thus, the historical analytic epidemiology approach for estimating risks by relating exposure to clinical disease (morbidity and mortality) may be supplemented by a fuller method, one that identifies intervening relationships more precisely or with greater detail than in the past. As a result, health events are less likely to be viewed as dichotomous phenomena (presence or absence of disease) but rather as a series of changes in a continuum from homeostatic adaptation, through dysfunction, to disease and death (Schulte, 1987, 1989; National Research Council, 1991b). Significant side benefits of this research modality include: (1) an improvement in the accuracy of exposure variables; (2) a contribution to the understanding of underlying pathogenic mechanisms inherent in the study of events at the molecular, cellular, or tissue levels; (3) the potential for more accurate and etiologic classifications of environmental diseases; and (4) the possibility that recognition of early effects could prompt strategies for secondary prevention or early disease modification (Hulka and Wilcosky, 1988). Quantitative consideration of the events in the exposure-dose-disease continuum has implications for dose-response assessment and could provide insight on how to extrapolate from high to low exposure levels, the reliability of extrapolation from laboratory species to humans, the relevance of certain physiologic events to disease outcome, and an index of human interindividual variation.

The progression from exposure to disease as shown in Figure 2-1 has been characterized by a number of authors and scientific committees on the use of biomarkers (Perera, 1987; Schulte, 1989; National Research Council, 1987, 1991a,b). It should be pointed out that components in the progression shown in Figure 2-1 are not necessarily discrete or the only events in the continuum. There may be a series of other components (steps or stages) between or in parallel with these that have yet to be discovered (Schulte, 1989). The similarity of this paradigm to that presented in Figure 1-2, as proposed by laboratory toxicologists, is striking and emphasizes the interdisciplinary and collaborative nature that will be required of future research on disease etiology and of associating causality to events along the continuum for use in dose-response assessment. Due to the anticipated impact that biological markers will have on future epidemiologic research and the potential for use of

such data in health risk assessment, this section will discuss the evolving concepts and definitions of biological markers and provide a framework for their validation and use in dose-response assessment. Methodologic issues and their effect on research design will be discussed in subsequent sections on the use of epidemiologic and nonepidemiologic data. It should be noted that many of these considerations are the same for any bioassay, as the level of sensitivity of the measured effect moves from the macro (e.g., histopathology) to molecular (e.g., receptor binding) level.

Concepts and Definitions

Because it is important that risk assessors understand the purpose of a given marker, that is, the reason the marker is being considered and what aspect of the exposure-dose-disease ("response") association it is supposed to indicate, markers are often classified into three broad categories: markers of exposure, disease, or susceptibility. It must be emphasized that this classification depends on the state of knowledge concerning the mechanistic relationship between the marker and the conditions of exposure, disease, or susceptibility that the markers represent. Thus, allocation of markers to one or more of three categories is subjective and could change (National Research Council, 1991b).

External exposure is defined as the sum amount of the xenobiotic material presented to an organism, whereas internal dose is the amount actually absorbed into the organism. An effect is defined as: (1) an actual health impairment or (by general consensus) recognized disease, (2) an early precursor of a disease process that indicates a potential for impairment of health, or (3) an event peripheral to any disease process but correlated with it and therefore predictive of development of impaired health. An intrinsic genetic or other characteristic or a preexisting disease that results in an increase in the internal dose, the biologically effective dose, or the target tissue response can be markers of increased susceptibility (National Research Council, 1987).

As shown in Figure 2-1, along the progression from exposure in the environment to the development of clinical disease, four generic component classes of biologic markers can be delineated: (1) indices of the internal dose, (2) indices of the biologically effective dose, (3) early biologic effects, and (4) altered structure and function. Clinical disease can also be represented by biologic markers for the current disease as well as by markers for prognostic

significance. Internal dose is the amount of xenobiotic substance found in a biologic medium; the biologically effective dose is the amount of xenobiotic material that interacts with critical subcellular, cellular, and tissue targets or with an established surrogate target tissue. A marker of early biologic effect represents an event that is correlated with, and possibly predictive of, health impairment. Altered structure and function are precursor biologic changes more closely related to the development of disease. Markers of clinical disease and of prognostic significance show the presence and predict the future of developed disease, respectively. Markers of susceptibility are indicators of increased (or decreased) risk for any component in the continuum. Even before exposure occurs, there may be biological differences between humans that cause some individuals to be more susceptible to environmentally induced disease (National Research Council, 1987,1991a,b).

A marker may be: (1) an actual measure of an event, such as blood lead to indicate exposure; (2) a surrogate for an event, such as creatinine clearance for renal function; (3) a correlate of an event, such as DNA adducts to reflect organ-specific exposure; or (4) a risk predictor, such as human lymphocyte antigen (HLA) B27 for ankylosing spondylitis (Schulte, 1989). Therefore, biological markers are tools that can be used to provide greater resolution of aspects of exposure-disease associations, that is, to clarify the relationship, if any, between exposure to a xenobiotic compound and health impairment.

Framework for Validation and Use

Although the development and use of biologic markers is increasing at a rapid rate, the validity and meaning of many of the markers need to be established before they can be used as analogous to "exposure" or "disease" in classical epidemiologic research and prior to their use in quantitative dose-response assessment. The key to relating variables in the exposure-dose-disease continuum and to validation is agreement on what constitutes a "critical effect". A critical effect is the biologic marker deemed most representative of a particular component in the continuum and ultimately most pathognomonic (Schulte, 1989). There is a need to have general agreement on which of these are critical (i.e., indicating some aspect of a disease response) and which are merely adaptive. This usually requires a series of independent studies, primarily toxicologic, and then clinical and epidemiologic, as delineated in Table 2-1. Knowledge of these steps can be useful in evaluating data that may characterize

TABLE 2-1. STEPS IN THE DEVELOPMENT OF A BIOMARKER

Step	Action Required	Relative Importance ^a
1. Chemical Selection	Prioritize based on occurrence, significant human exposure, potential for adverse human health effects.	C
2. Conceptualization	Identify logical consequence of chemical exposure that might serve as a useful measure of exposure.	C
3. Confirmation of Concept	Experimentally confirm the validity of the basic concept.	C
4. Develop Method of Measurement	Identify method for reliably detecting changes in biomarker at doses at or below those producing toxic effects.	C
5. Biomarker Practical for Field?	Develop feasible field methodology and develop sufficient sensitivity of biomarker to monitor existing exposures.	L
6. Establish Dose-Response Relationship	Characterize pharmacokinetics and metabolism of chemical. (Consistent relationship to systemic dose is critical; knowledge of effective dose is limiting.)	C,L
7. Identify Variables Affecting Relationship with Dose	Establish specificity of response and identify lifestyle, genetic, disease state, therapeutic, or occupational variables that modify the response.	C,L
8. Measures Toxic Effect?	Identify advantages of this biomarker among other biomarkers of equal efficacy as measures of exposure.	N
9. Validation of Applicability to Humans	Conduct pilot study in small groups of humans with defined exposure gradients to the chemical of interest.	C
10. Conduct Demonstration Study	Determine whether variation in response in larger population can be accounted for by known variables.	C

^aC = Critical to the application of the biomarker; L = Limiting to the application of the biomarker (i.e., places limits on interpretation of results for secondary purposes) (e.g., risk assessment); N = Nice to have, but not essential to the application of the biomarker.

Source: Adapted from Bull (1989).

biomarkers as surrogates for dose or disease to determine dose-response relationships. As more causal component associations are identified, it becomes necessary to elucidate quantitative relationships of the kinetics, natural history, and rates of transition along the continuum. The hypothesis of the role that the marker has in the disease development should sustain throughout these refinements. Subsequently, it is necessary to relate critical effects to dose estimates, to determine what factors affect dose, and to define a no-observed-adverse-effect level (NOAEL).

Reliability and Validation

Because biological markers are measurements, they have inherent signals (true effects) and noise (random errors). Measurement errors need to be acknowledged and controlled since failure to do so may lead to a decreased sensitivity due to the lack of reliability in the measurements, which may lead to systematic biases or correlations toward underestimation, a need for increased sample size, and bias selection in case-control studies. It is recommended that a pilot reliability study be performed as standard practice.

The validity of a biologic marker can be viewed in terms of "measurement validity" as used in epidemiology (Schulte, 1989; National Research Council, 1991b). Three aspects of validity have been defined: (1) construct validity (i.e., the ability to correspond to theoretical constructs under study [e.g., if some event such as kidney function changes with age, then a marker with construct validity should also change]), (2) content validity (i.e., the domain of the phenomenon under study is incorporated [e.g., a DNA adduct for aromatic amines will represent exposure from various routes and from occupational and lifestyle exposures]), and (3) criterion validity (i.e., the extent to which the marker correlates with an external measure of the phenomenon under study). There are two types of criterion validity: concurrent validity and predictive validity. Concurrent validity is when the marker and the criterion refer to the same point in time (e.g., exhaled breath measures could be validated against ambient air measures of occupational exposure to a chemical). Predictive validity indicates the ability of a marker to predict a criterion (e.g., detection of a marker can be validated against the appearance of an effect).

It is necessary to have precise, accurate, sensitive, specific, and reliable assays for each component estimate and an understanding of the factors that influence them (Schulte, 1987;

Griffith et al., 1988). A validated relationship between the various components along the exposure-dose-disease continuum (Figure 2-1) would include knowledge established at four levels (Gann, 1986): (1) the association between a marker and a preceding exposure or subsequent effect; (2) the location, shape, and slope of the exposure marker, or of the marker-effect relationship; (3) the threshold of "no observed adverse effect"; and (4) the positive predictive value of the marker for exposure or for disease. The validity may be assessed in terms of sensitivity, specificity, disease frequency, and predictive value. The relationship between these parameters and ways to calculate them are provided in detail elsewhere (Schulte, 1989; Khoury et al., 1985; Griffith et al., 1988). A qualitative rating scale for the validity of biologic markers is provided in Table 2-2.

TABLE 2-2. QUALITATIVE RATING FOR VALIDITY OF BIOLOGIC MARKERS

-
-
- (1) "Totally experimental", with complete uncertainty about health or exposure significance of results.
 - (2) Experimental, but theoretical reasons exist to suggest that the marker will correlate with exposure or disease.
 - (3) Correlates well with exposure or disease, but significance of the data is still uncertain.
 - (4) Probably correlates well with exposure or disease, but truly conclusive data are not available.
 - (5) Extensively studied and has been validated as a useful tool for monitoring exposure or disease, but gives an unexpected positive response in 10% of people screened.
 - (6) Extensively studied and has been validated as a useful tool for monitoring exposure or disease, but gives an unexpected negative response in 10% of people screened who have a history of chronic abnormal exposure.
 - (7) Extensively studied and has been validated as a useful tool for monitoring exposure or disease, with no or very rare false positives and negatives.
 - (8) Validated and is completely predictive of exposure or disease.
-
-

Source: Schulte (1989).

Conceptually, the goal of validation is to explore and establish links between markers along the exposure-dose-disease continuum. The conventional approach to validation is to

relate a critical effect to exposure or dose, or to toxic effects. It has also been suggested that validation of biologic markers include testing the association for one component of the continuum and any other critical component elsewhere in the continuum (Schulte, 1989), as shown in Figure 2-2. This approach is consistent with the iterative process of research and the steps in development of biologic markers, as discussed. The risk assessor should consider the degree to which these criteria have been addressed for a biomarker when considering its application to dose response assessment. Hattis (1991) offers guidance on and provides examples of how to incorporate biomarkers and pharmacokinetic analysis into risk assessment.

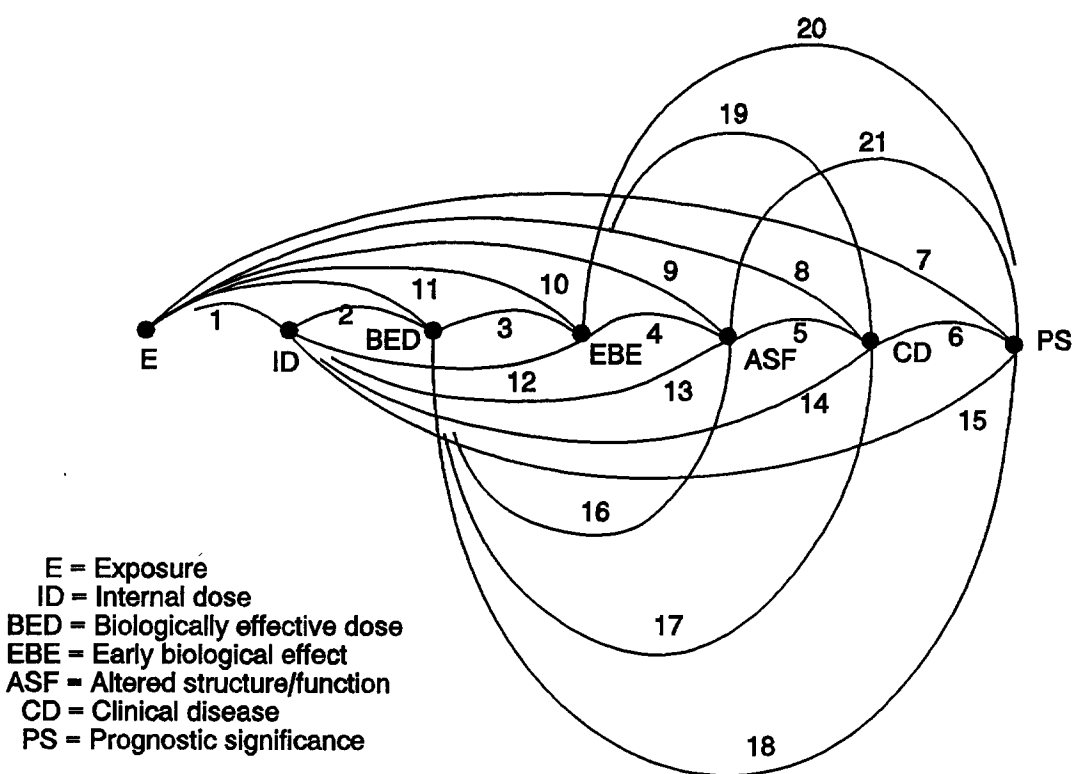

Figure 2-2. Schematic representation of possible relationships (1 to 21 pairs) to research using biologic markers.

Source: Schulte (1989).

Analytic Issues

The conventional techniques for assessing exposure-disease associations, for screening for disease in populations, and for handling multiple variables can be practiced for any two or more components in the continuum. The major assumption that permits this approach is that there is an association between the component markers. Figure 2-2 shows the 21 possible pairwise relationships that may be evaluated along the continuum between exposure and disease. The ability to characterize these relationships is dependent on the degree of mechanistic knowledge, whereas the importance of each of these will vary depending on the priorities and objectives of the investigators and/or the application to dose-response assessment.

Essentially, at issue is whether the marker is truly an intervening variable or a confounding factor. Any marker that represents a step in the causal progression between exposure and disease is not a confounding factor but, in fact, is an intervening variable. When there is uncertainty about the mechanism, handling a potential confounding factor as both confounding and not confounding in different analyses is justified. Seasoned judgment of the best available information in the face of lack of mechanistic data will be required.

Relationships between components in the continuum can be modeled by two approaches: empirical and process modeling. The empirical approach can be used when there are no explicit hypotheses about components. The approach is to use statistical techniques to find the combination of descriptors that "best" explain the observed effects (e.g., gauging the relative appropriateness of different dose surrogates determined principally by the nature of the pathogenesis process) (Schulte, 1989). For use in dose-response assessment, it is also necessary to determine the extent that a marker reflects recent or past exposures, peak as opposed to integrated exposures, and cumulative rather than noncumulative biologic effects (Checkoway and Rice, 1992). The process modeling approach uses quantitative toxicologic models to estimate concentrations in biological compartments and temporal patterns of occurrence. It requires explicit hypotheses. Process modeling should be the goal as more is learned about the continuum.

Biologic Exposure Indices

Perhaps the one area where use of biologic markers has achieved the most success as applied to dose estimation is in setting biologic exposure indices (BEI) based on occupational epidemiology and experimental studies. Figure 2-3 shows the relationship between air monitoring and biologic monitoring as practiced for risk management of occupational exposures. Air monitoring and its related threshold limit value (TLV), usually expressed as a time-weighted average (TWA), is a measure of external dose, whereas biological monitoring and the associated BEI relates to indirect monitoring of the internal dose (Droz, 1985). Air monitoring as often conducted, however, does not reflect unexpected exposure resulting from peculiarities of certain jobs or from poor working practices (Fiserova-Bergerova, 1990), so that surveillance of workers by monitoring BEIs is recommended (American Conference of Governmental Industrial Hygienists, 1986).

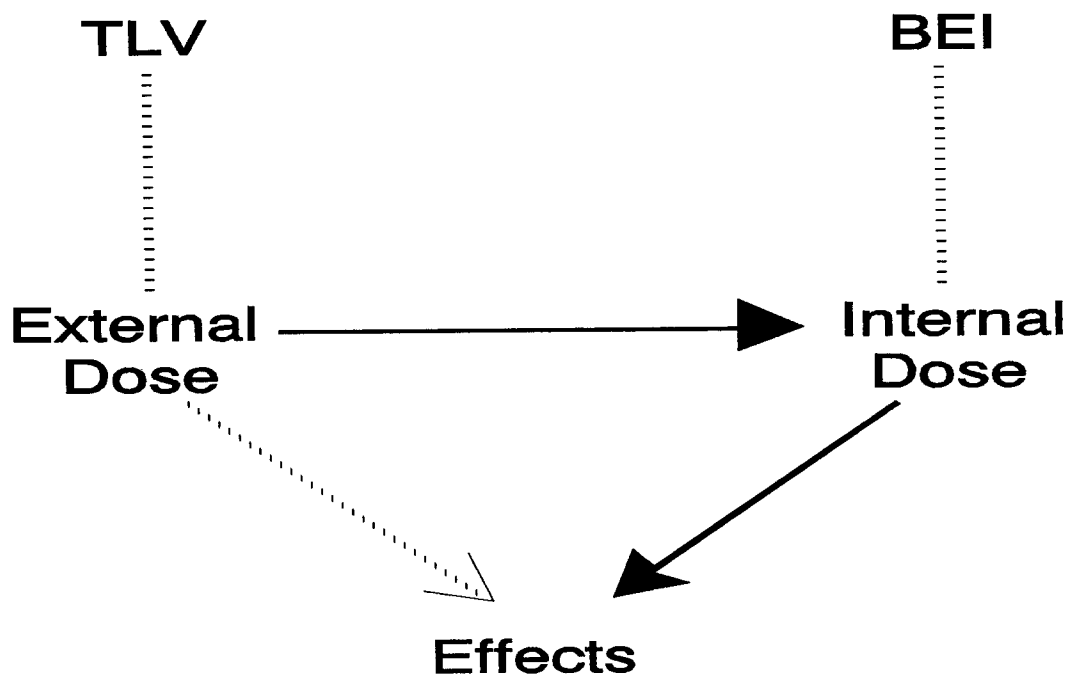

Figure 2-3. Schematic relationships between threshold limit values in air (TLV), biologic exposure indices (BEI), and effects.

Source: Droz (1985).

In order to develop and set a BEI, the relationship between internal dose (i.e., the BEI) and health effects should be established. However, most of the available toxicologic data relate exposure dose directly to health effects. In order to make use of these data, approaches to development of the BEIs recommended by the ACGIH have considered that the BEIs are bioequivalent to the TLV (Droz, 1985). A similar type of reasoning can be used to establish NOAELs or lowest-observed-adverse-effect levels (LOAELs) associated with occupational epidemiology exposures. Exposure estimates such as a TWA (or other exposure measure [e.g., duration or cumulative exposure]) are a measure of the composition of the external environment surrounding a worker. The BEI is a measure of an internal dose farther along the exposure-dose-disease continuum, and as such can better reflect individual exposure variability and response. Therefore, appropriate BEI levels can serve as dose surrogates, associated with an observed effect in a population (e.g., lower confidence limit on mean metabolite in blood) then extrapolated back to exposure estimates in order to calculate a human equivalent concentration (HEC).

The correlation between the degree of exposure and biological levels is influenced by variability in the exposure concentration (temporal repetition, intraday concentration variation, and interday concentration variation) and individual variability (workload, body build, and metabolism). The relationships between exposure levels and BEIs can be established using three main approaches: (1) epidemiologic field studies on groups of workers or populations exposed to the chemical in question; (2) experimental or clinical studies on volunteers exposed in controlled chambers; and (3) PBPK simulation studies, using different kinds of mathematical models to allow the simulation of various exposure situations and individual characteristics (Droz, 1985; Fiserova-Bergerova, 1990). These three approaches are complementary and each has its own advantages and disadvantages, as qualitatively summarized in Table 2-3. The ranking of these factors depend heavily on experimental design and could be quite different for a particular chemical or set of studies. The BEI documentation for individual chemicals should be consulted for considerations pertaining to these modifying factors and their influence on interpretation of results (American Conference of Governmental Industrial Hygienists, 1986).

TABLE 2-3. COMPARISON OF THE QUALITIES OF FIELD AND EXPERIMENTAL APPROACHES IN THE STUDY OF THRESHOLD LIMIT VALUE/BIOLOGIC EXPOSURE INDICES RELATIONSHIPS

Factor	Approach	
	Field	Experimental
Exposure (dose) measurement	+ +	+ + +
Physical workload characterization	+	+ + +
Timing of biological sampling	+	+ + +
Effects of exposure repetition	+ + +	+ +
Environmental variability	+ +	+ +
Representativity of the subjects	+ + +	+

+++ = Good; ++ = Medium; + = Poor.

Source: Droz (1985).

Application of Physiologically Based Pharmacokinetic Models

Physiologically based pharmacokinetic models are simulation models described by simultaneous differential equations, the number of which is dictated by the number of compartments needed to describe the physiological and metabolic processes involved. In the context of characterizing the exposure-dose-disease continuum, simulation models can be considered as complementary, providing critical insight on key processes related to the fate of chemicals in the body and for depicting the contribution of various exposure and biological factors to the variability of response. That is, these models can provide the following information on which biological monitoring (e.g., BEIs) is designed and data are interpreted: (1) concentration-effect relationships, (2) time-effect relationships, (3) matching exposure in the workplace with integrated exposure, (4) depicting effects of external and internal factors that alter the relationship between intensity of exposure and biological concentration and body burden of the biologic marker, (5) extrapolation and prediction of biological concentrations resulting from exposure to new compounds or new exposure conditions, and (6) verification of data (Leung, 1992; Fiserova-Bergerova, 1990; Leung and Paustenbach, 1988; Droz, 1985). Simulation models, because of their ability to match the extent of exposures associated with the predetermined dose or biological markers of exposure, are a valuable tool

in extrapolation of reference values for workers with unusual workshifts (Andersen et al., 1987b; Saltzman, 1988).

2.1.1.2 Epidemiologic Data

There are essentially three areas of concern in assessing the quality of an epidemiologic study. These involve the design and methodological approaches used for: (1) exposure measures, (2) effect measures, and (3) the control of covariables and confounding variables (Lebowitz, 1983). The study population and study design must adequately address the health effect in question in order to support a risk assessment (Lebowitz, 1983). In order to accomplish this goal, the exposure measures must be appropriate and of sufficient quality; the statistical analysis methods must be suitable to the study design and goals; the health effect measures must be reliable and valid; and the covariables and confounding variables need to be controlled or eliminated. Additional guidance on evaluation of the quality of individual epidemiologic studies is provided in Appendix B. Criteria for causal significance are provided in Appendix C.

Assessment of Exposure Measures

The problem of the accuracy and relevance of exposure measurements is not unique to epidemiologic investigations, but it can be exacerbated due to the long-term nature of these studies. For example, the nature of aerometric data may change over time because of different air sampling techniques. Exposures also change over time because of different industrial hygiene practices and because individuals change jobs and residences. Accurate documentation of air toxicant levels, therefore, is critical in determining the usefulness of an investigation as well as documentation that the analysis of the air toxicant is appropriate and of sufficient sensitivity. It also is advisable to have the concentrations of other pollutants reported and considered in the statistical analyses to help rule out confounding or interactive effects. The number, location, and timing of monitors should be suitable to allow an appropriate determination of exposure of the subjects to the pollutant being studied and to the pollutants that could confound the results. When appropriate, the exposure measure or estimate should take into account indoor/outdoor exposures and activity and subject location data. Unfortunately, exposure measures often are the weakest component of an

epidemiologic study. Minimally, the exposure measure or estimate needs to be representative of the actual exposure.

Assessment of exposure measures should attempt to establish whether the following wide range of aspects (National Research Council, 1991a) were addressed:

- Contaminant and potential biological response
- Specification and selection of the target population
- Spatial and temporal variability of concentration distribution patterns
- Frequency and intensity of exposure
- Selection of the sampling period in appropriate relationship to the time scale of biological effect (e.g., peak exposure versus TWA; short-term versus lifetime)
- Precision and accuracy requirements.

Exposure measures employed can either be direct (e.g., personal monitoring and in some cases biological markers) or indirect (e.g., environmental monitoring such as area samples, models that predict spatial and temporal concentration distributions of air contaminants in microenvironments, questionnaires, and questionnaires or diaries). Each type has distinct advantages and disadvantages, and depending on the nature of the agent in question, may address the above aspects to greater or lesser degrees.

Assessment of Effect Measures

Effect measures refer to the methods used to define disease indices. For epidemiologic studies, these include incidence, standardized mortality ratios, and relative risk ratios.

Criteria for assessment require the proper selection and characterization of both the exposed and control groups. For example, criteria for inclusion in the control category of a case-control study must ensure that this group has no exposure to the agent of concern. For studies without internal control groups, reference populations are needed, particularly when evaluating spirometric data (Ferris, 1978; American Thoracic Society, 1979; Crapo et al., 1981; Knudson et al., 1976). Each population used to predict "normal" pulmonary function tests has its own characteristics, which should be considered when used for comparisons.

Other considerations include the adequacy of study duration and quality of the follow-up. A disease with a long latency before clinical presentation requires a longer study duration than one with an acute onset. Valid ascertainment (such as verification according to the International Classification of Diseases IX) of the causes of morbidity and death also is necessary.

Evaluation of epidemiologic studies may require interpretation of a variety of subjective health effects data. Questionnaire responses may be biased by the way questions are worded, the training of an interviewer, or the setting. However, a study based on a high-quality questionnaire can provide useful results. For example, a committee of the American Thoracic Society (ATS) charged with defining an adverse respiratory health effect, has come to a consensus that "in general, increased prevalence of chronic respiratory symptoms as determined from questionnaire surveys should be considered to be an adverse health effect" (American Thoracic Society, 1985). Questionnaires should be validated as part of the investigation protocol, unless a standard questionnaire that has previously been validated is used (Medical Research Council, 1960; Ferris, 1978; National Institute for Occupational Safety and Health, 1986).

It is very important to consider differences between statistical significance and medical or biological significance. Both the variability of an outcome measure and the magnitude of an exposure's effect determine the level of statistical significance. For example, data from a large study population analyzed with sophisticated techniques may yield statistically significant effects of small magnitude that cannot readily be interpreted biologically. Conversely, apparently large changes of clinical importance may not be statistically significant if the study population is too small. In addition, some studies present false negative or no-effect results due to the lack of power. Judgments concerning medical or biological significance should be based on the magnitude and class of a particular effect. For example, cough or phlegm production can be considered less important than effects resulting in hospital admissions, but daily productive cough can be more important than infrequent cough. Underlying assumptions and nuances of the statistical procedures applied to the data also need to be considered. This will probably best be accomplished on a case-by-case basis.

Because the RfC considers both portal-of-entry and remote (systemic) effects, it would be helpful to define an "adverse respiratory health effect." An ATS committee published

guidelines that defined such an effect as medically significant physiologic or pathologic changes generally evidenced by one or more of the following (American Thoracic Society, 1985):

- Interference with the normal activity of the affected person or persons
- Episodic respiratory illness
- Incapacitating illness
- Permanent respiratory injury or
- Progressive respiratory dysfunction

Appendix D provides detailed descriptions of adverse respiratory effects in humans.

Assessing the Control of Confounding and Covariables

Epidemiologic investigations attempt to relate an exposure to a given health effect, but this includes accounting for the "background" health effect (pathologic condition) that exists in individuals due to predisposing factors and preexisting health conditions, or from other variables, such as occupational exposures.

Various host factors contribute as risk factors for disease and can influence the health indices assessed. For example, asthmatics may be particularly susceptible to effects from exposure to irritant gases. Epidemiologic evaluation of these factors often not only accounts for such interactions but also can help to characterize susceptible or sensitive groups. Covariables can be as important as the major aerometric variables themselves in affecting human health. Other exposures, such as concomitant occupational exposures and smoking, in particular, can affect the disease outcome. Meteorologic variables such as air velocity, temperature, and humidity also are very important factors when considering respiratory health effects. These covariables should be controlled by both the study design and analysis, as appropriate.

The final step in the inferential process from an epidemiologic investigation is the extension of the study results to persons, populations, or settings not specifically included in the experimental design, that is, to demonstrate consistency of results within replicates in

different scenarios. The confidence with which this is done for positive results is usually based implicitly on how successful the investigators have been in identifying and handling the potential risk factors and covariables that produce or influence the pollution-effect association they have observed. Uncertainties also arise because the general population includes some people, such as children, who may be more susceptible than people in the epidemiologic study. Factors such as the "healthy worker" effect and the bias of a predominantly male worker sample must be considered when using occupational studies (National Research Council, 1985). Intraindividual variability concerns are addressed in Section 2.1.1.4.

2.1.1.3 Nonepidemiologic Data

Human data also include clinical studies and case reports. The case reports may provide support for the weight-of-the-evidence decision, but are often of limited utility in establishing a quantitative relationship between environmental exposures and anticipated effects (Barnes and Dourson, 1988). Controlled human clinical studies, properly conducted, can be of great value to dose-response assessment. Although such studies for ethical reasons are typically for acute durations and therefore, by definition, do not meet the criteria for development of a chronic RfC estimate, they can be valuable in improving understanding of the nature of the effect in humans. Some of the discussion found in Section 2.1.2.2, Impact of Experimental Protocol (for laboratory animal studies), is also appropriate to consider.

Clinical Studies

Clinical studies may contain exposure-response information that can be used in estimating effects. Most clinical studies combine the strong point of animal toxicology, rigorous control of the experimental exposure and subject, with the strong point of epidemiology, the unquestioned relevance to human health. In addition, clinical studies can be independently confirmed somewhat more easily (requiring a reasonably short time and resource commitment) than epidemiologic studies. There are limitations, however, that include short exposure duration and "noninvasive" techniques that might not ascertain the full array of effects. The test atmospheres are usually within the range expected to produce only mild and temporary health effects. Certainly, clinical studies should be recognized and given credence to the extent that they are scientifically rigorous, relevant to human health concerns,

and have been independently replicated. They may be particularly useful for acute or less-than-lifetime dose-response assessment. The prediction of long-term effects from short-term observations remains questionable, but confidence in clinical findings can be bolstered by supporting evidence from epidemiology and laboratory animal toxicology, and vice versa.

Although clinical exposures and respiratory measurements (at least the noninvasive ones for functional mechanics) are typically done on nonsedated humans, the breathing pattern remains an important consideration. Experimental protocol often dictates the breathing pattern (i.e., nonspontaneous breathing) where a subject patterns his or her breathing to a metronome or is instructed to take a deep breath on every fifth inhalation. Because the efficiency of time-dependent deposition mechanisms is greater during inspiration than expiration, an ideal "academic" breathing pattern would keep the inspiration time/expiration time ratio (t_i/t_e) constant (Heyder et al., 1975). Relevance of such an academic pattern to risk assessment, however, remains equivocal and most investigations do not attempt to maintain a constant ratio. Documentation of breathing patterns should be included in the experimental protocol and considered in the extrapolation of dose.

The exposure mode is also important to consider. Because the nasal passages are more efficient at removing particles (particularly for large particles) than the oral cavity, increased lung deposition of larger particles could occur through mouth breathing. This would affect both the amount and the size distribution of an inhaled aerosol in the lower respiratory tract. Even the specific configuration of the mouthpieces used in inhalation exposures delivered orally can affect the extent of deposition (Schlesinger, 1985). Miller et al. (1988) showed that regional respiratory tract deposition of insoluble particles in humans is a complex function of breathing route, ventilatory level, and the particulate physicochemical and aerodynamic properties. Some gases (especially highly water soluble and reactive ones) are extensively removed in the nasal passages, making exposure mode important for gases as well. Whether the subjects were free-breathing or whether they breathed through a mouthpiece or used a facemask affects gas deposition as well and should be considered.

Case Reports

Individual case reports of adverse effects due to a specific agent also can provide some help in evaluating the potential risk from exposure to a toxic air pollutant. These reports are

especially valuable qualitatively for indicating that the quantitative effect observed in animals occurs in exposed humans. These reports must be examined carefully and used with discretion because they represent a very small sample and are usually related to heavy exposures (Goldstein, 1983). Nevertheless, these observations should not be overlooked, especially when a large number of case histories exist with the same endpoint.

2.1.1.4 Intraspecies Variability and Identifying Sensitive Subgroups

In order to control factors other than the chemical being tested, laboratory animals (e.g., rodents) used in toxicity studies are often bred for homogeneity. In contrast, the human population is heterogeneous. The broad genetic variation of the human population in processes related to chemical disposition and tissue response causes individual differences in sensitivity to toxic chemicals. A susceptible individual is one who will experience an adverse health effect to a pollutant significantly earlier in the course of exposure or at lower doses than the average individual, because of host factors that predispose the individual to the harmful effects. Sensitive individuals may be those whose genetic makeup puts them at the extreme end of a continuous distribution of a biological function, such as the amount of enzyme production, or those who possess a unique genetic difference, such as an altered enzyme, that makes them markedly different from the general population.

In addition to genetic factors, personal characteristics such as age, sex, health status, nutrition or personal habits make some people more susceptible (Calabrese, 1978). The activity pattern of people is a major host factor influencing the dose-response by its effect on delivered dose. Generally, exercise increases the delivered dose and alters the regional deposition of the dose.

Environmental risk assessment also should consider host factors that both increase susceptibility and that occur relatively frequently in the population. Erdreich and Sonich-Mullin (1984) estimated the prevalence of population subgroups who are potentially hypersusceptible to some common pollutants. Table 2-4 shows five subgroups of individuals who, based on empirical observations or compromised physiological functions, are assumed susceptible to the listed chemicals. Theoretically, elderly individuals could be more susceptible to some chemicals and children to others. Unfortunately, very little is known about this important area. Likewise, very little is known about gender differences.

TABLE 2-4. PREVALENCE OF SUBGROUPS SUSCEPTIBLE TO EFFECTS OF COMMON POLLUTANTS

Susceptibility Subgroup	Population Prevalence	Chemicals ^{*,a}	Reference
Embryo, fetus, neonate	Pregnant women: 21/1,000 ^b	Carcinogens, solvents, CO, mercury, lead, PCBs, pesticides	Rice (1981), Kurzel and Cetrulo (1981), Saxena et al. (1981), U.S. Environmental Protection Agency (1986a, 1991)
Young children	Ages 1-4: 70/1,000 ^b	Hepatotoxins, PCBs, metals, NO ₂	Calabrese (1981), Friberg et al. (1979), U.S. Environmental Protection Agency (1993a)
Chronic obstructive pulmonary disease	Chronic bronchitis: 13,494,000 (5.4%) ^c Asthma: 12,375,000 (4.9%) ^c Emphysema: 1,915,000 (0.8%) ^c	O ₃ , Cd, particulate matter, SO ₂ , NO ₂	Holland et al. (1979), Redmond (1981), U.S. Environmental Protection Agency (1982b; 1993a,b)
Circulatory conditions	Ischemic heart disease: 8,155,000 (3.2%) ^c	Chlorinated solvents, fluorocarbons, CO	McCauley and Bull (1980), Aviado (1978), U.S. Environmental Protection Agency (1991)
Liver disease	Liver abnormalities: 20/1,000 ^d	Carbon tetrachloride, PCBs, insecticides, carcinogens	Calabrese (1978)

***Abbreviations:**

CO = Carbon monoxide;

PCBs = Polychlorinated biphenyls;

O₃ = Ozone;

Cd = Cadmium;

SO₂ = Sulfur dioxide;

NO₂ = Nitrogen dioxide.

^aRepresentative samples of chemicals to which these individuals may be susceptible. Some evidence from laboratory animal studies only.

^bEstimates of Erdreich and Sonich-Mullin (1984) from 1970 census statistics data.

^cPopulation base 251,448,000; estimate from U.S. Department of Health and Human Services (1992).

^dEstimate of Erdreich and Sonich-Mullin (1984) from Health Interview Survey (National Center for Health Statistics, 1975).

Source: Adapted from Erdreich and Sonich-Mullin (1984).

As a result of epidemiologic investigations, it is well recognized that a population of adult workers experiences less morbidity and mortality than the general population (Fox and Collier, 1976; Wen et al., 1983; Monson, 1986). However, sufficient qualitative and

quantitative information on interindividual variability and susceptibility for specific chemicals rarely exists.

If the RfC is based on data derived from subgroups of the general population, such as workers who are generally a selected group of healthy adults, the calculation procedures must include an appropriate uncertainty factor (UF) to account for the anticipated broader variability in the general population. Worker populations are nonrepresentative in terms of sex, age distribution, and general health status. Susceptible subpopulations may not be represented because they may not seek or sustain employment, particularly in situations such as those represented in workplace exposure studies. Occasionally, data are available on more sensitive subgroups such as children or asthmatics. In these cases, dose-response assessments can be made for the general population with greater confidence. In the absence of data on the more susceptible individuals in the population or lack of identification of such individuals, UFs are used to protect unidentified individuals at greater risk.

There are two steps necessary to obtain information addressing the problem of sensitive individuals: (1) examine chemical-specific data for empirical evidence of sensitivity and hypersusceptibility, and (2) ascertain whether the mechanism of toxicity for a given chemical suggests that any population group would be more sensitive.

In addition to this chemical-specific evaluation, guidance should be developed concerning the prevalence of sensitive subgroups and the range of sensitivities in the general population exposed to inhaled toxicants. Some research has assessed the magnitude of interindividual variability in pharmacokinetic parameters related to the delivery of the biologically effective dose, in order to develop guidance for appropriate UFs. Differences among normal healthy adults may be as much as 10-fold (Hattis et al., 1987). Therefore, the potential that exists for broad differences when children, the elderly, the ill, and those previously exposed are included.

2.1.1.5 Summary

Based on the foregoing discussion, guidelines for the qualitative assessment of human data are as follows:

Evaluation of the Epidemiologic Data Base

- Examine epidemiologic and clinical data for dose-response information in potential or previously identified sensitive groups (e.g., studies in asthmatics and children).
- Examine laboratory animal data for models that may help identify potential sensitive individuals.
- Evaluate epidemiologic studies to ascertain genetic and personal factors that increase the risk of adverse response. Evaluate implications of these risk factors for identifying sensitive groups.
- Examine data for reports of ranges of responses or response variables, and for information on individual responses. This is particularly important in evaluating human data for assessing the range of variability in response because epidemiologic studies may find a LOAEL with no NOAEL.
- Evaluate available biological monitoring data and clinical and experimental data for indications of characteristics of increased susceptibility. For example, irritants may induce responses earlier in individuals with asthma.
- Evaluate data on mechanisms of toxicity, pharmacokinetics, and critical target organs to identify characteristics that may imply broad interindividual variability or susceptible individuals. For example, the elderly may be more sensitive to certain chemicals in relation to age-related changes in oxidative metabolism potential.

Evaluation of Individual Studies

- Assess the makeup of the study population and control groups to identify the presence or absence of sensitive individuals. Data on healthy workers, for example, are not representative of the general population and will require reduction of NOAELS or LOAELS by UFs.
- Consider the activity pattern of the subjects. Whether the subjects received exposure while at rest or at level(s) of exercise that influenced the inhaled dose as well as the pattern of deposition.
- In longitudinal (cohort) studies, evaluate information in relation to the natural history of the disease (e.g., the progression of lesions). For example, normal changes over time, such as increased forced expiratory volume at 1 s (FEV₁) as children get older, and decline of FEV₁ with aging in older adults, should not be adversely affected. Cross-sectional studies may suggest such associations but will not support causality as strongly as will cohort studies.
- For parameters that have known variability with age, such as FEV₁, evaluate results within age groups and ascertain whether appropriate reference populations were used.

2.1.2 Laboratory Animal Data

When the data base lacks adequate information on effects in humans, as is frequently the case, the key studies are drawn from experiments conducted on nonhuman mammals. Animals most often used include the rat, mouse, guinea pig, hamster, rabbit, monkey, and dog. Such animal studies have often been conducted with controlled exposure conditions on relatively homogenous populations, but nevertheless, present the risk assessor with concerns about evaluating dose and exposure regimen. Unlike the human, inbred laboratory animals have homogeneous constitutions. Genetic background differences and numerous other interspecies differences are confounding factors during key study selection.

Evaluation of the quality of individual animal toxicity studies requires consideration of factors associated with the study's hypothesis, design, execution, analysis, and interpretation. Guidelines for assessing individual animal studies are provided in Appendix F and are adopted from a number of recommendations (National Research Council, 1984; Society of Toxicology, 1982; James, 1985; Muller et al., 1984; Lu, 1985a). Refer to this appendix for a more detailed description of those issues.

2.1.2.1 Study Design

An ideal study addresses a clearly defined hypothesis, follows a carefully prescribed protocol, is conducted in adherence to good laboratory practice, and includes appropriate and sufficient subsequent analysis to support its conclusions. The EPA Good Laboratory Practice Standards (Code of Federal Regulations, 1991b,c) are designed to ensure the quality and integrity of data used in hazard evaluation. These regulations contain detailed guidance on provisions for personnel, facilities for animal care, animal supply, handling of test and control substances, equipment, operation of testing facilities, characterization of test and control chemicals, protocol and conduct of a laboratory study, report records, record storage, and record retrieval. Studies that do not precisely follow these guidelines may still be judged adequate if, in the context of overall results, the deviations are not important. The type of deviation (from the guidelines) and its magnitude, as well as the potential for its interaction among all the variables, must be assessed (National Research Council, 1984). For example, a study may still be judged adequate, despite an insufficient number of test animals specified

by the appropriate reference protocol guidelines, if the results are so definitive that the addition of more test animals would almost certainly not have affected the conclusion. A dose-response assessment that is based on a study with deficiencies may include a modifying factor to account for the added uncertainty (see Section 4.3.8.2).

The use of statistics in design and interpretation of studies is an area in animal toxicity testing that is often neglected or applied inappropriately (Muller et al., 1984). Consideration of statistical applications restricted to confirmatory analysis (i.e., outcome is dependent on the mathematically randomized test condition and is independent of other observations) versus exploratory analysis (i.e., many tests on a variable) should be emphasized.

2.1.2.2 Impact of Experimental Protocol

The techniques and measurements used in inhalation toxicology investigations may affect the exposure conditions or the interpretation of toxic effects, thereby altering the results used for risk assessment. Areas that introduce uncertainty into interspecies extrapolations of inhaled dose include measurement techniques, the definitions and underlying assumptions used in the procedures, and the exposure technology. Careful consideration should be given to each when estimating the effective inhaled dose. This discussion is also appropriate to consider when evaluating clinical human studies.

Equipment Specifications

The equipment used will impart restrictions on any interpretation (i.e., limitations of sensitivity for exposure analysis or to monitor an effect) of investigative results and therefore should be considered when evaluating test results.

Generation and Characterization of Exposures

Just as the working definitions and underlying assumptions alter the interpretation of measurement techniques, the operative exposure level (e.g., for use in risk assessment, prediction models, etc.) of a test agent is a function of how its particulate mass and composition (mean particle diameter and distribution) and gas concentration are expressed. Other specific characteristics (e.g., adequate test substance mixing in chamber, hygroscopicity, charge density) should be accounted for as part of this description. The

soundness and interpretation of the animal data are dependent on the methods employed to generate and analyze the test atmosphere data because the methods influence deposition calculations.

The two most common ways in which particle size is expressed are the count median diameter (CMD) and mass median diameter (MMD). The toxicity of a material is most consistently related to its mass distribution. Measurement of mass has the further advantage of a minor quantitative error at the small end of the size spectrum. To assess risk, however, the activity diameter may be a more appropriate expression of particle size as discussed in Appendix H. Methods of particle measurement include settling, filtration, wet and dry impingement, multiple impaction, electrical precipitation, thermal precipitation, centrifugation, and observation of optical effects. Each of these has its own principle of operation and limits of sensitivity that, in turn, affect the expression or characterization of the test aerosol. Fiber exposures are further complicated by the need to describe the aspect criteria and distributions. As discussed in the section on anatomy and physiology, certain mechanisms contribute to the deposition fraction in each respiratory region. Failure to account for characteristics such as hygroscopicity or charge density when generating an aerosol could change its deposition in certain regions. This variability in the aerosol characterization would be expressed as uncertainty in the dose-response assessment.

Gaseous contaminant atmospheres are usually somewhat easier to characterize. Delivered concentrations must be consistent across exposure location and duration and may be less than the generated concentration. If the gas is extremely reactive, loss due to reactions with the walls of the transport system (e.g., tubing) and chamber will occur. Losses due to decomposition or alteration of the test substance during some generation procedures also may be a factor. Gas flow rate (delivery) must be known, steady, and calibrated for the given gas because it is density-dependent. Analysis of the air is limited by the detection device specifications. If online analysis is not feasible, consideration should be given to the frequency of samples taken. The period between samples for intermittent analysis should be less than one-tenth of the total exposure time for any given day (McKenna, 1982).

For all generation and characterization of pollutants, periodic calibration of all measurement systems is a critical quality control/quality assurance step. This also needs to be considered when evaluating the study, as discussed in Appendix F.

Generation of the compound under study and subsequent exposure also will affect the derived inhaled dose. Exact determination of the dose achieved in inhalation studies is a complex process. Proper generation, appropriate characterization, and accurate delivery of the test atmosphere are integral to this determination. Varieties and limitations of the available technology must be considered when evaluating the selection of methods and interpreting experimental results. The reader is referred to review articles for details on inhalation exposure systems (Cheng and Moss, 1988; Barrow, 1988; Moss and Cheng, 1988; Gardner and Kennedy, 1993).

Exposure Regimen

Extrapolation from one exposure regimen to another has uncertainties, most of which are not quantified. For most chemicals, the quantitative relationship between the toxic effect and concentration or duration of exposure is not studied. Some studies have indicated that the relationship is dependent on many factors, including (1) the number of exposure hours per day; (2) the exposure scenario, that is, continuous versus interrupted (e.g., 1 week of exposure, 1 week of air, 1 week of exposure, etc.), versus intermittent (X hours per day, Y days per week) regimens; (3) the time of endpoint assessment (e.g., acute versus subchronic versus chronic studies or studies with recovery time before observation); (4) the endpoint(s); and (5) the mechanisms of toxicity. Examples of particles and gases follow that illustrate some of the complexities involved in extrapolating across exposure scenarios.

The actual amount of particles or gas found in the respiratory tract at any time is determined by the relative rates of deposition and clearance. The efficiencies of the deposition mechanisms are different in each respiratory tract region. The defense mechanisms and clearance rates for each of these regions also are different. Therefore, it is expected that the kinetics of the toxic effect of an exposure will be influenced by the duration of exposure. There is experimental evidence for such a differential dependence of effect on exposure duration. For example, Albert et al. (1971) showed that low single doses or early effects of repeated exposure to cigarette smoke were associated with acceleration of clearance rates in the tracheobronchial trees of both donkeys and humans. Heavier doses and long-term repeated exposures were associated with sporadic clearance, stasis intervals, and some retrograde movement. Unfortunately, there has not been a systematic comparison and

quantification of differential clearance rates across species. This will be necessary before the effects of duration can be assessed in the same models or default values can be developed.

Ozone can be used as an illustration for gases because it has a large health effects data base. Kenoyer et al. (1981) showed that rats exposed to O₃ for 4 h showed delays in the early clearance and an acceleration in the late clearance rate of tracer particles. These investigators postulated that the delays in early clearance could be caused by effects that decrease mucous transport (e.g., decreased ciliary beat rate or change in mucous properties), whereas acceleration of the late clearance rate was most likely due to an increase in numbers or activities of alveolar macrophages. Rats exposed intermittently (7 to 8 h/day to O₃ for approximately 1 week) had similar changes in lung antioxidant enzymes to animals exposed continuously (24 h/day), even though the dose, expressed as the product of concentration (C) and time (T) of exposure, was different (Mustafa and Lee, 1976). Monkeys exposed to O₃ for 18 mo continuously or for 18 mo bimonthly (equivalent to 9 mo of exposure) had some similar alterations in lung morphology; additional alterations were observed in the intermittent exposure group although they received a lower C × T (Tyler et al., 1985). Using morphometric measurements of the proximal alveolar region of lungs of rats receiving prolonged low-level exposures of O₃, Huang et al. (1988) have shown that the increase in the relative volume of Type I epithelial cells was related to the C × T, whereas other morphometric indices were more dependent on concentration than on time.

For nitrogen dioxide (NO₂), the data base is equally complex on the exposure scenario issue. Using the mouse infectivity model (an index of antibacterial lung defenses), concentration was found to be more important than duration of exposure in causing the effect (Gardner et al., 1979). When a typical urban pattern of NO₂ was used (i.e., a baseline of continuous exposure to a low level of NO₂ on which were superimposed two 1-h peaks of NO₂ each weekday), the study indicated that on a C × T basis, this regimen was not more toxic than a continuous exposure to the baseline level after a short period of exposure (Graham et al., 1987). After a chronic exposure, the spikes to the baseline increased the effects relative to the baseline exposure only (Miller et al., 1987a).

The topic of extrapolating across different exposure scenarios is beyond the scope of this document. However, the few examples provided illustrate the complexity of the issue with respect to concentration and duration. Other factors that also influence interspecies

extrapolation (e.g., temperature, humidity, particle size, and distribution are discussed) in Chapter 3. Risk assessors will have to consider the effects of exposure on a case-by-case basis and utilize default assumptions until the needed research data are available.

Exposure Modes

The various exposure techniques can be divided according to the extent to which the test species are exposed. The techniques range from whole-body exposure at the one extreme to exposures limited only to the lower respiratory tract (Lippmann, 1980). These techniques include whole-body, head-only, nose-only, nasal, oral, and tracheal cannula exposures, and tracheal instillations. Practical considerations such as economic feasibility, special precautions for safe and efficient generation, amount of material, test compound stability, exposure duration, and the measurements desired dictate the selection of an exposure technique for a given study design. For example, whole-body exposure of laboratory animals in cages is the most common method to conduct chronic inhalation exposures for more than 1 to 2 h/day, whereas nose-only exposures are most often used for short durations particle exposures.

Wolff et al. (1982) studied the deposition and retention of 0.1 μm radiolabeled gallium oxide ($^{67}\text{Ga}_2\text{O}_3$) aggregate aerosols in Fischer 344 rats following whole-body and nose-only exposures of 3 days duration. In this investigation, lung deposition for whole-body exposures was similar to that for nose-only exposures ($\sim 15\%$ of the inhaled particles). Due to preening, passage of material into the GI tract, however, was 1.6-fold greater for whole-body exposures than with nose-only exposures. This could be important in cases where there is either a specific GI response (i.e., stomach lesions) or substantial GI absorption that may result in a systemic effect.

Rotation of animals in whole-body chambers is recommended and should be included in the experimental design (Griffis et al., 1981) to minimize dosimetric differences that would result if the aerosol was not uniformly distributed in the chamber. The effects of factors such as heat and/or other stress upon animals in confinement tubes used for nose- or head-only exposures need to be considered, particularly because these factors may be species-dependent. For example, rats in confinement tubes for short exposures have been shown to have respiratory values and body temperatures that remain constant, although Syrian golden

hamsters exhibit increasing ventilation and temperature (Raabe et al., 1973). Adaptation to exposure or measurements may be a function of behavior, such as ability to be trained (Mauderly and Kritchevsky, 1979), but in general, animals in confinement tubes or animals forced to breathe through mouthpieces will experience abnormal stress (Raabe et al., 1973). Nose-only restraint was shown to induce indications of material toxicity but did not appear to affect normal embryo/fetal morphologic development in mice exposed on gestational days 6 through 15 for 6 h per day (Tyl et al., 1994). The potential for stress should be accounted for in the experimental protocol. The tubes can be modified into plethysmographs to monitor respiratory function changes indicative of stress, or cooled to a constant temperature to prevent it. If such modifications are not made, the risk assessor must be aware of potential influences on results.

Anesthesia

Anesthesia greatly influences the respiration characteristics of the test animal. This is a consideration when evaluating pulmonary function parameters for adverse effects. Prolonged anesthesia can compromise the respiratory system, altering normal function and response. Anesthesia also can alter the metabolism of the study compound. Anesthesia has been reported to interfere with autonomic control, produce atelectasis, decrease lung compliance, block reflex responses, and introduce an undesirable risk to animals committed to long-term toxicology studies (Dorato et al., 1983). These alterations in ventilation and breathing mechanics produced by anesthesia could have severe effects on the results of respiratory function measurements. This possibility provided the impetus for the development of procedures for measuring respiration in unsedated laboratory animals (Amdur and Mead, 1958; Mauderly et al., 1979). Data now are available on respiratory characteristics in sedated and unsedated animals; consideration of anesthesia should be included in data analysis to ensure appropriate comparisons.

Breathing Pattern

Consideration should be given to the possible alteration of the breathing pattern due to the exposure concentration, which, in turn, would alter the delivered dose. Exposure of certain agents, such as irritants, may lead to concentration-dependent changes in pulmonary

mechanics measurements (Costa and Tepper, 1988; Alarie, 1981). Correct quantification of inhaled dose therefore may require measurement of breathing pattern (respiratory frequency and V_T) during the course of the exposure. Differences in delivered "dose" correlated with the species-dependent differences in ventilation have been reported for formaldehyde toxicity (Chang et al., 1983).

Measurement Techniques

Because measurements of ventilation and breathing mechanics often are used to evaluate respiratory functional alterations or to estimate inhaled/retained dose, performance parameters of such measurements are critical to their interpretation. The patterns of respiration (breathing route, depth, and rate) affect the air flow characteristics, which, in turn, influence the relationship between competing particle deposition mechanisms and the relative contribution of gas transport processes. The penetration depth of the exposure air is determined by the tidal volume (V_T), the airway caliber, and the ratio of functional residual capacity to total lung capacity (FRC/TLC). As the FRC/TLC increases, deposition would be expected to increase (Schlesinger, 1985). For example, rapid shallow breathing often is associated with increased deposition of larger particles in the upper respiratory tract, as compared to slow, deep breathing. Therefore, performance parameters include both the factors that influence the test species (including human) respiration characteristics and the performance limitations of the techniques.

Pharmacologic Effects of Agents

The test agents may affect lung ventilation and function. Administration of a chemical with narcotic properties will lower physical activity, whereas an irritant might increase movement. The test agent could also alter clearance mechanisms. All of these states would affect deposition, uptake, and retention of the dose. In addition, the agent could disrupt the immune system and render the animal more susceptible to disease during long-term testing, thereby altering the study results.

There are several examples of irritating or potentially anesthetic chemicals that can depress ventilation. Chang et al. (1983) reported a 40% decrease in minute volume in mice exposed to 15 ppm formaldehyde. This inhibition was maintained during the entire course of

the daily exposure period. Ventilation was decreased to as little as 1/15 of resting values during exposure of mice to 10 ppm ozone (O₃), and to as little as 1/3 of resting values during exposure of mice to acrylate esters (Bruce et al., 1979).

Particle overloading in the lungs of laboratory animals is a recognized outcome of excessive particle exposures, especially during chronic inhalation studies. The phenomenon has been associated both with protracted retention time of particles in the lung and with changes that can confound toxicological interpretations (Morrow, 1992). Concurrent and persistent features of the progressive prolongation of pulmonary retention include histological evidence of aggregated alveolar macrophages (AM) engorged with phagocytized dust particles, chronic inflammatory response, increased uptake of particles in the interstitial spaces, and an increased alveolar cell hyperplasia. Subsequent development of alveolitis, granulomas, and fibrosis are related to the duration and severity of the overload condition. Morrow (1988) has developed the hypothesis that excessive levels of dust (particles) in the lungs lead to excessive engulfment of particles by AMs and after a certain degree of loading occurred, the AMs become progressively immobilized and aggregated. The activated AM can also release mediators that can affect the integrity of the epithelial barrier, inhibit antiproteases, or cause influx of inflammatory cells. The relative or complete loss of AM mobility increases the likelihood of direct particle-epithelial cell interactions and interstitial localization of dust particles. The impact of this phenomenon is likely modulated by the particle surface properties, the amount of dust phagocytized, the intrinsic cytotoxicity of the particles and the persistence of the particle laden cells in the lung milieu.

It has been concluded that particle overloading seriously confounds toxicological interpretations in the F344 rat (Morrow, 1992) and has important implication for most species, including humans. At this juncture, differentiating overload effects from those induced by the intrinsic toxicity of the inhaled material relies to a major extent on the characterizing the toxic potency of the particles. If the possibility for a particle overload phenomenon exists, caution is warranted in the use of first-order kinetics to describe clearance kinetics. Models that incorporate realistic functional and cytological bases and appropriate kinetic descriptions such as that of Yu and Yoon (1990) to describe diesel particle clearance, are necessary to describe both reasonable and excessive particle dust burden retention.

Definitions/Underlying Assumptions

Additional variability and uncertainty in evaluating available inhalation studies occur because investigators have used different definitions of various respiratory regions and have employed different methods to estimate total or regional deposition. For example, total deposition often is estimated by calculating the difference between the amount of compound in the inhaled air and that in the exhaled air. By making assumptions about mixing and dead space, estimates of regional deposition may be obtained using measurements of the compound concentration in different volume fractions of the expired air. As another example, the definition of upper respiratory tract in various studies has included any or all of the following anatomic regions: nasopharynx, oropharynx, larynx, or upper trachea. In other studies, deposition values based on chemical or radiologic assays of tissues after exposure assume no particle translocation before or during dissection. Some investigators include measurement of material in the gastrointestinal (GI) tract in their reported value for upper respiratory tract deposition, while others ignore this translocation. The underlying assumptions and working definitions for different experimental conditions can contribute a large degree of variability in reported results. Conversion to some common basis will be necessary in order to calculate and accurately compare inhaled doses.

2.1.2.3 Appropriateness of Laboratory Animal Species as a Model for Humans

For inhalation studies in particular, there is a dichotomy in terms of the types of endpoints monitored in human versus laboratory animal studies. Human data concerning the consequences of inhalation exposure generally consist of information on subjective symptoms along with clinical data concerning pulmonary function. The relationship between the clinical picture and lung pathology is poorly defined. However, standard animal toxicological protocols generally incorporate respiratory tissue evaluation as part of the routine necropsy, but do not evaluate pulmonary function. Of course, once the lung has been identified as a target tissue, more detailed studies of it as a target organ may be conducted. When these more detailed data are available, two additional questions are raised: (1) What is the significance of alterations in test species' pulmonary performance in terms of potential human effects? and (2) If tests showing differences in pulmonary biochemistry are available, what is the utility of the biochemical changes as predictors of disease? Correlations between

functional decrements and immunologic, biochemical, and pathologic changes need to be quantitated. Work in progress on animal models (see Section 3.1.2.1), biological exposure indices (Lowry, 1986), and in vitro alterations of lung biochemistry as predictive of lung disease (Last, 1983) are contributing to this end.

Each inhalation study should be evaluated for possible indications that the respiratory system is the critical target organ. Human studies that provide only cursory evaluation of respiratory endpoints make careful evaluation of animal data essential. Human data should be evaluated with special emphasis on the significance of respiratory system endpoints and adequacy of their characterization. Extrapolation from oral to inhalation exposures may be utilized only after careful consideration of factors presented in Section 4.1.2.

For compounds that appear to produce their critical effect within the respiratory system itself, decisions concerning adversity need to be made on a case-by-case basis. Appendix D provides specific information concerning evaluation of the severity of respiratory tract endpoints in humans, while Appendix E provides a summary of issues and references for pulmonary function evaluation.

Emphysema provides an example of some of the complexities involved in this issue. Appropriate animal model selection may be contingent upon pathological identification of early changes consistent with the human syndrome; for example, a clear choice of the most appropriate laboratory animal species has not been established for emphysema (Snider et al., 1986). The most recent definition of emphysema by the National Heart Lung and Blood Institute, Division of Lung Diseases Workgroup (Snider et al., 1985), differentiates between emphysema in human lungs and animal models of emphysema. When reports of emphysema following exposures of animals are to be extrapolated to potential hazards for humans, the definition of human emphysema, rather than that for laboratory animal models of emphysema, must be used. Thus, the current definitions of emphysema in human lungs and in laboratory animal models are critical to this review (U.S. Environmental Protection Agency, 1993a).

The report from the National Institutes of Health (Snider et al., 1985) first defines respiratory airspace enlargement. "Respiratory airspace enlargement is defined as an increase in airspace size as compared with the airspace size of normal lungs. The term applies to all varieties of airspace enlargement distal to the terminal bronchioles, whether occurring with or

without fibrosis or destruction." Emphysema is one of several forms of airspace enlargement. In human lungs, "Emphysema is defined as a condition of the lung characterized by abnormal, permanent enlargement of airspaces distal to the terminal bronchiole, accompanied by destruction of their walls, and without obvious fibrosis." Destruction is further defined: "Destruction in emphysema is further defined as nonuniformity in the pattern of respiratory airspace enlargement so that the orderly appearance of the acinus and its components is disturbed and may be lost." The report also indicates that "Destruction...may be recognized by subgross examination of an inflation-fixed lung slice..." Emphysema in laboratory animal models was defined differently. The stated reason for this difference in the definitions of emphysema in humans and in laboratory animal models was "In order to foster the development of new knowledge, animal models of emphysema are defined as nonrestrictively as possible: An animal model of emphysema is defined as an abnormal state of the lungs in which there is enlargement of the airspaces distal to the terminal bronchiole. Airspace enlargement should be determined qualitatively in appropriate specimens and quantitatively by stereologic methods." Thus, in laboratory animal models of emphysema, airspace wall destruction need not be present. "Appropriate specimens presumably refers to lungs fixed in the inflated state and is similar to the 1962 American Thoracic Society Committee's requirement for tissue fixation. This document states "It is still not clear whether the airspace enlargement of age is due to age alone or to the combination of age and environmental history, but the occurrence of these changes in nearly all subjects suggests that the changes are normal" (Meneely et al., 1962). Control animals of the same age as the experimental animals appear necessary to avoid potential confusion due to age. This National Institutes of Health committee also noted that, to date, animal models of emphysema fall into two general classes. "The first class centers on testing the pathogenicity of agents suspected of being relevant to the genesis of emphysema; models produced by NO₂, cadmium, and tobacco smoke are examples of this type. The second class of models is analytical, for testing specific hypotheses of the pathogenesis of emphysema."

Thus, in reviewing reports of emphysema following experimental exposure to a toxicant, important considerations include (1) whether the tissue was fixed in an inflated state; (2) whether airspaces distal to the terminal bronchiole were enlarged beyond normal and whether that enlargement was determined quantitatively by stereologic methods (control

animals of identical age as exposed animals should be used for sterologic studies to exclude the possibility that airspace enlargement was due to age); and (3) whether or not airspace wall destruction, as defined by the NHLBI workgroup (Snider et al., 1985), was present. The presence of airspace wall destruction, as defined by the NHLBI workgroup, is critical. In published reports of emphysema following exposure to a toxicant evidence of airspace wall destruction can only be obtained by careful review of the authors' description of the lesions or by examining the micrographs the author selected for publication. Thus, although a particular animal species may share a number of similarities with humans in respiratory tract physiology, it may be dissimilar in crucial parameters and, therefore, be a less than adequate source as a model.

Sensory Irritation

One endpoint that is specific to inhalation is sensory irritation. Sensory irritants are defined as chemicals that stimulate trigeminal nerve endings in the cornea and nasal mucosa and that evoke a stinging or burning sensation. This perception can be accompanied by irritation of the throat and coughing from stimulation of laryngeal nerve endings. Sensory irritants induce, among other effects, a postinspiratory apnea in experimental animals, resulting in a decrease in breathing rate. A test for sensory irritation in laboratory animals was developed, based on the premise that if sensory irritation can be prevented then systemic effects will be prevented as well (Alarie, 1984). The test is based on the decrease in respiratory frequency occurring in numerous laboratory animals (cats, dogs, mice, rats, rabbits, and guinea pigs) when exposed to chemical irritants. The decrease in respiratory rate was found to be concentration-related. The RD_{50} is the concentration that induces a 50% decrease in respiratory rate and it has been proposed as the basis of comparison for the irritating potencies of chemicals (Kane et al., 1979; Alarie, 1984). The test has become a standard method adopted by the American Society for Testing and Materials.

It should be emphasized that the mechanism of sensory irritation is a different mechanism than that by which stimuli (physical, toxicologic, or pharmacologic) cause obstruction in the lower respiratory tract regions (tracheobronchial and pulmonary). In fact, the epidemiology of bronchial or airway responsiveness and the mechanisms underlying the physiologic phenomenon of airway hyperresponsiveness still are not completely understood.

Multiple mechanisms have been suggested and one or another may predominate in any given individual. Possible mechanisms include: alterations in airway geometry, disordered autonomic regulation of smooth muscle tone, structural alterations in airway smooth muscle, increased accessibility of stimuli to the muscle, and the release of locally acting mediators of inflammation. Atopy is a multifactorial trait, both genetically and environmentally determined, and is only one mechanism by which levels of airway responsiveness can be increased.

The relationship of sensory irritation to airway irritation is unknown. It is known that irritation and toxicity can interfere with trigeminal nerve stimulation. An evaluation of the sensory irritation test for the assessment of occupational health risk found that quantitative evaluation with respect to human data was not possible due to a number of factors, including interlaboratory differences in ability to perform the test and intra- and interspecies inconsistencies in response (Bos et al., 1992), although correlation of RD₅₀ values with TLV values has been demonstrated (Schaper, 1993). Histopathology has also been reported after short-term exposure to the RD₅₀ concentration for some irritants (Buckley et al., 1984). For these reasons, the suitability of the sensory irritation test results is limited to serving as an indication of the potential for respiratory tract irritation. Dose-response assessment of the sensory irritation test is not recommended especially for quantitative evaluation of chronic effects.

Asphyxiation

Another effect specific to the inhalation route is asphyxiation. This effect is thought to be brought about by reversible, "physical" interactions of gas molecules with biomolecules (e.g., "displacement" of oxygen by carbon dioxide) (Tichy, 1983). The vapor pressure of a liquid or solid at ambient temperatures determines the maximum exposure concentration (MEC) for its vapor. The MEC in parts per million may be calculated from the vapor pressure (VP) at 25 °C according to

$$\text{MEC (ppm)} = \frac{\text{VP}_{25^\circ\text{C}} \text{ (mm Hg)}}{760 \text{ mm Hg}} \times 10^6. \quad (2-1)$$

Knowing the VP of a liquid or solid is important for estimating its capacity to produce reversible effects. A compound with a VP of less than 0.76 mm Hg at room temperature will attain an air concentration of less than 1,000 ppm at the saturated vapor concentration. This concentration is below the limits for which narcotic or anesthetic effects are generally observed (Tichy, 1983). Therefore, if a material has a VP of less than 0.76 mm Hg, its potential to produce such effects can reasonably be ruled out (Dahl, 1990).

Allergic Sensitization

Although most pollutants would be expected to elicit a dose-response upon exposure, some pollutants cause tolerance/adaptation and some act by allergic or asthmatic mechanisms. Allergic sensitizers may be considered a subgroup of the agents that produce their critical effect in the respiratory system. Sensitization is typically caused by high initial doses. Subsequently, any challenge level of exposure (including low concentrations) may be sufficient to induce the asthmatic syndrome in sensitized individuals. There is evidence that IgE antibody levels and inflammatory pulmonary reactions play a role in such syndromes. Toluene diisocyanate is a well-known example of a sensitizing agent that affects immunological and pharmacological mechanisms and induces asthma.

The potential for chemicals to induce an airway immune response is related to their ability to interact with human airway proteins resulting in haptization or the formation of new antigenic determinants. Hence, if the structure of the compound suggests that it is reactive or if it is related to one of the chemicals known to elicit hypersensitivity in humans (Table 2-5), it is suspect as a potential sensitizing agent. Classes of compounds that have been most extensively studied for the effects are the anhydrides, isocyanates, and some of the metal salts.

Several methodologies are now available that test chemicals for their sensitizing potential. Three of the major approaches include: (1) the Karol method (Karol et al., 1985; Karol, 1994), (2) the Sarlo method (Sarlo et al., 1992), and (3) the Dearman/Kimber method (Dearman et al., 1992). None of the methods have been well validated for a range of chemicals and all have drawbacks. The reader is referred to the summary of workshop entitled "The Status of Test Methods for Assessing Potential of Chemicals to Induce Respiratory Allergic Reactions" (Selgrade et al., 1994) and to Briatico-Vangosa et al.

TABLE 2-5. AGENTS CAUSING WHEEZING AND BRONCHOCONSTRICTION

Large molecular weight compounds	Cyanuric chloride
Animals proteins	Platinum salts
Laboratory animals	Dyes
Domestic animals	Azo, anthraquinone, remazol black B dye
Birds	Diisocyanates
Sea squirts	Toluene diisocyanate
Prawns	Diphenylmethane diisocyanate
Grain weevils	Hexamethylene diisocyanate
Mites	Antibiotics
Arthropods	Metallic salts
Enzymes (animal)	Nickel
Subtilisin	Chromium
Trypsin, pancreatin	Aluminum
Plant proteins	Fluxes
Cereal grains	Colophony
Legumes (coffee, soy, castor bean)	Aminoethylethanolamine
Pollen	Miscellaneous
Seeds (cotton, flax, linseed)	Formaldehyde
Enzymes (plant)	Piperazine
Papain, bromelain, pectinase, diastase	Plicatic acid
Vegetable gums	Pyrethrins
Karaya, tragacanth, acacia (arabic), quillaja	Extract of henna
Fungi	
Mold	
Inorganic and organic compounds of small molecular weight	
Abietic acid	
Anhydrides	
Phthalic, trimellitic, hexahydrophthalic, tetrachlorophthalic, himic	

Adapted from: Moller et al. (1986); Selgrade et al. (1994); Briatico-Yangosa et al. (1994).

(1994) for additional information and guidance on hazard identification and assessment of respiratory allergic reactions.

Summary

Identification of the most appropriate laboratory animal species is the end result of an interpretative process that examines all facets of a data base from study design to data relevance to the extrapolation methodology.

The most sensitive species is selected from evaluation of key studies. Although this approach (i.e., NOAEL identification) may have the advantage of affording a greater degree of protection, the species most sensitive to an agent may not be as toxicologically relevant as other species for extrapolation to humans because of a variety of interspecies variables.

Selection of an appropriate animal model and key study depends on the depth of understanding of the human disease syndrome, adverse effect, or indicator of toxicity selected as the criterion for evaluation. For agents whose toxicological outcome is dependent on the degree to which it is metabolized, the most appropriate animal species is contingent upon proper evaluation of the numerous interspecies differences with respect to metabolism (see also Section 3.2). The studies of Plopper et al. (1983) suggest that animal species differ widely in metabolizing potential of the respiratory tract. Hamsters and rabbits have much greater metabolizing potentials than do monkeys and rats. Interspecies differences in the metabolic pathway, as shown for xylene (National Toxicology Program, 1986), may serve as a basis for selecting one study for RfC derivation and rejecting another. Species-dependent variables in mucous production and secretion are factors in selecting an appropriate animal model (see also Chapter 3) for irritants.

The subject of appropriate animal models has been reviewed (Hakkinen and Witschi, 1985) and various mammalian species (rat, hamster, and rabbit) were identified as appropriate species for extrapolation from several perspectives. Other reviews that discuss the current limitations and need for the development of animal models as surrogates for humans include those of Reid (1980), Slauson and Hahn (1980), and Calabrese (1983).

2.1.2.4 Study Validity and Relevance to Extrapolation

The validity of the study and its relevance to human extrapolation is another major area to consider when assessing individual animal studies. It involves the evaluation of a number of factors, including all elements of exposure definition (concentration, duration, frequency, administration route, and physicochemical characterization of the chemical used), reliability of and limits to the procedures used for both exposure and effects measurements, relevance of the exposure level tested to the anticipated human exposure level, nature of the effect (consistency with the area of toxicology assessed and the suspected mechanism of action), and the similarities and differences between the test species and humans (e.g., in absorption and metabolism).

Animal studies are conducted using a variety of exposure scenarios in which the concentration, frequency, and duration of exposure may vary considerably. Studies may use different durations (acute, subchronic, and chronic) as well as schedules (single, intermittent, and continuous). All of these studies contribute to the hazard identification of the risk assessment. Special consideration should be addressed to those studies of appropriate duration for the reference level to be determined (i.e., chronic investigations for the RfC).

These exposure concerns (concentration and duration) are compounded when the risk assessor is presented with data from several animal studies. An attempt to identify the animal model most relevant to humans should be made on the most defensible biological rationale (e.g., comparable metabolism and pharmacokinetic profiles). In the absence of such a model, the most sensitive species (i.e., the species showing a toxic effect at the lowest administered dose) is adopted for use as a matter of science policy at the EPA (Barnes and Dourson, 1988). This selection process is more difficult if the laboratory animal data are for various exposure routes, especially if the routes are different from that in the human situation of concern.

Because the data base may be deficient for the route of exposure of interest, it is the EPA's view that the toxicity potential manifested by one route can be indicative of potential toxicity via any other exposure route unless convincing contrary evidence exists (Barnes and Dourson, 1988). Quantitative extrapolation, however, requires consideration of the differences in the dosimetry for the chemical resulting from the different exposure routes. Detailed consideration is given to route-to-route extrapolation in Section 4.1.2.

2.1.3 Summarizing the Evidence

The culmination of the hazard identification phase of any risk assessment involves integrating a diverse data collection into a cohesive, biologically plausible toxicity "picture"; that is, to develop the weight of evidence that the chemical poses a hazard to humans. The salient points from each of the laboratory animal and human studies in the entire data base should be summarized as should the analysis devoted to examining the variation or consistency among factors (usually related to the mechanism of action), in order to establish the likely outcome for exposure to this chemical. From this analysis, an appropriate animal model or additional factors pertinent to human extrapolation may be identified.

The utility of a given study is often related to the nature and quality of the other available data. For example, clinical pharmacokinetic studies may validate that the target organ or disease in laboratory animals is likely to be the same effect observed in the exposed human population. However, if a cohort study describing the nature of the dose-response relationship were available, the clinical description would rarely give additional information. An apparent conflict may arise in the analysis when an association is observed in toxicologic but not epidemiologic data, or vice versa. The analysis then should focus on reasons for the apparent difference in order to resolve the discrepancy. For example, the epidemiologic data may have contained other exposures not accounted for, or the laboratory animal species tested may have been inappropriate for the mechanism of action. A framework for approaching data summary is provided in Table 2-6. Table 2-7 provides the specific uses of various types of human data in such an approach. These guidelines have evolved from criteria used to establish causal significance, such as those developed by the American Thoracic Society (1985) to assess the causal significance of an air toxicant and a health effect. The criteria for establishing causal significance can be found in Appendix C. In general, the following factors enhance the weight of evidence on a chemical:

- Clear evidence of a dose-response relationship;
- Similar effects across sex, strain, species, exposure routes, or in multiple experiments;
- Biologically plausible relationship between metabolism data, the postulated mechanism of action, and the effect of concern;

**TABLE 2-6. APPROACH FOR SUMMARIZING THE EVIDENCE
FROM DIVERSE DATA**

CONCEPT 1: STRENGTH OF THE ASSOCIATION

The stronger the association, the greater the confidence that the agent causes the effect.

- Presence of low LC₅₀, low NOAEL, high potency index
- Dose-response gradient evident
- High incidence rate, large excess risk
- High level of statistical significance in relevant studies

CONCEPT 2: CONSISTENCY

The association is observed in various circumstances.

- Observed in a number of experimental species
- Various routes
- Different dose regimens
- Descriptive epidemiologic data
- Analytical epidemiologic studies

CONCEPT 3: BIOLOGICAL PLAUSIBILITY

The association is plausible in terms of other scientific information related to the putative causal mechanism.

- A gradient of responses observed
 - Short-term or in vitro tests
 - Pharmacokinetics
 - Molecular action and pathology
 - Structure-activity relationship
 - Preclinical indicators
 - Biological monitoring of exposure
-

Source: Erdreich (1988).

- Similar toxicity exhibited by structurally related compounds;
- Some correlation between the observed chemical toxicity and human evidence.

The greater the weight of evidence, the greater the confidence in the conclusion derived.
Developing improved weight-of-evidence schemes for various noncancer health effect

TABLE 2-7. HUMAN DATA FOR USE IN HEALTH RISK ASSESSMENT

Study (Alternative Terms)	Comment on Potential Use
EPIDEMIOLOGIC DATA	
Cohort (longitudinal, prospective, incidence)	Rates as percent response useful in risk assessment. Measure of excess risk can be obtained. If dose or exposure data are available, dose-response curves can be constructed. Studies with ordinal exposure data support strength of evidence and hazard identification.
Case-control (retrospective, dose or case-referent)	No direct measure of disease rates. If exposure data are available, a NOAEL may be identified. ^a Studies with ordinal or nominal exposure data may support strength of evidence and hazard identification.
Cross-sectional (prevalence) ^b	Similar to case-control for short-term effects. Prevalence data less reliable for effects from chronic exposures.
Geographic correlation ^b	An inexpensive screening procedure. Crude indicator of potential hazard. Rates are usually only indirectly related to exposure. Generates hypotheses for analytical studies.
Clinical trials	Generally not applicable to environmental issues, because exposures are treatments or preventive measures. Intervention trials in which an exposure is removed or changed (e.g., medication, smoking, diet) are useful in strength of the evidence for evaluating causality.
NONEPIDEMIOLOGIC DATA	
Experimental studies	The only human data with controlled exposure levels. Usually interval level exposure data but low dose, limited exposure time. Use for hazard identification and dose-response assessment.
"Exposed-control" comparisons (noncohort; see text for discussion)	Rates may be biased because of self-selection or incomplete ascertainment of exposed population. Cannot be used to support absence of hazard. Clinical descriptions useful for hazard identification.
Case series ^c	Can be used to demonstrate hazard if syndrome is unusual. Usually high level, short-term exposure. May yield data point for adverse-effect levels. Cannot be used to show absence of hazard.
Case reports	Suggests nature of acute endpoints in humans. Cannot be used to support absence of hazard.

^aExposure history is difficult to reconstruct, particularly outside of the occupational setting.

^bMay be available pertinent to air pollution exposure.

^cSeveral cases seen by or reported by a single investigator. Cases may be attributed to unique exposure incident, but total exposed population is not defined.

Source: Adapted from Erdreich and Burnett (1985).

categories has been the focus of efforts by the Agency to improve health risk assessment methodologies (Perlin and McCormack, 1988).

Another difficulty encountered in this summarizing process is that certain studies may produce apparently positive or negative results, yet may be flawed. The flaws may have arisen from inappropriate design or execution in performance (e.g., lack of statistical power or adjustment of dosage during the course of the study to avoid undesirable toxic effects). The treatment of flawed results is critical; although there is something to be learned from every study, the extent that a study should be used is dependent on the nature of the flaw (Society of Toxicology, 1982). A flawed negative study could only provide a false sense of security, whereas a flawed positive study may contribute to some limited understanding. Although there is no substitute for good science, grey areas such as this are ultimately a matter of scientific judgment. The risk assessor will have to decide what is and is not useful within the framework outlined earlier.

Studies meeting the criteria detailed in Sections 2.1.1 and 2.1.2 (epidemiologic, nonepidemiologic data), and experimental studies on laboratory animals that fit into this weight-of-evidence framework are used in the quantitative dose-response assessment discussed in Chapter 4.

3. CONCEPTUAL BASIS FOR INHALATION DOSE-RESPONSE ASSESSMENT METHODOLOGY

As discussed in Chapter 1, comprehensive characterization of the exposure-dose-response continuum is the fundamental objective of any dose-response assessment. Species differences in anatomical and physiological characteristics, the wide range of physicochemical properties associated with inhaled chemicals, the diversity of cell types that may be affected, and a myriad of mechanistic and metabolic differences combine to make the characterization particularly complex for the respiratory tract as the portal of entry. This chapter attempts to discuss these factors within the exposure-dose-response context in order to present unifying concepts. These concepts are used to construct a framework by which to evaluate the different available dosimetry models; appreciate why they are constructed differently; and determine how the default approaches presented in Chapter 4 are derived.

3.1 FACTORS CONTROLLING COMPARATIVE INHALED DOSE

The various species used in inhalation toxicology studies do not receive identical doses in comparable respiratory tract regions when exposed to the same external particle or gas concentration (Brain and Mensah, 1983). The biologic endpoint or health effect, therefore, may be more directly related to the quantitative pattern of mass deposited within the respiratory tract than to the external exposure concentration. Regional deposition pattern determines not only the initial lung tissue doses but also the specific pathways and rates by which the inhaled agents are cleared and redistributed (Schlesinger, 1985).

This section discusses the issues associated with the two major factors controlling the deposition pattern: (1) respiratory anatomy and physiology (Section 3.1.1) and (2) the physicochemical characteristics of the inhaled toxicant (Section 3.1.2).

The factors that control inhaled dose are discussed relative to the significant mechanisms by which particles and gases may initially be deposited or taken up in the respiratory tract. Note that, in this document, disposition is defined as encompassing the processes of deposition, absorption, distribution, metabolism, and elimination. Initial deposition is used in

reference to gases as well as particles because contact with the respiratory tract surface precedes absorption. For particles, deposition mechanisms include inertial impaction, sedimentation (gravitational), diffusion, interception, and electrostatic precipitation, whereas mechanisms important for gases include convection, diffusion, chemical reaction (including metabolism), dissolution, and perfusion. Detailed consideration of these mechanisms is beyond the scope of this discussion. The reader is referred elsewhere for more extensive discussions of particle deposition (U.S. Environmental Protection Agency, 1982b, 1986c; Hatch and Gross, 1964; Raabe, 1979; Hinds, 1982; Lippmann and Schlesinger, 1984) and gas absorption (U.S. Environmental Protection Agency, 1986, 1993b; Fiserova-Bergerova, 1983; Overton, 1984; Overton and Miller, 1988).

It must be emphasized that dissection of the factors that control inhaled dose into discrete topic discussions is deceptive and masks the dynamic nature of the intact respiratory system. For example, although deposition in a particular respiratory region will be discussed separately from the clearance mechanisms for that region, retention (the actual amount of inhaled agent found in the lungs at any time) is determined by the relative rates of deposition and clearance. Retention and the toxicologic properties of the inhaled agent are related to the magnitude of the pharmacologic, physiologic, or pathologic response. Therefore, although the deposition, clearance mechanisms, and physiochemical properties of the agent are described in distinct sections, assessment of the overall toxicity requires integration of the various factors.

As discussed in Chapter 1, comprehensive description of the exposure-dose-response continuum requires integration of quantitative knowledge of appropriate mechanistic determinants of chemical disposition, toxicant-target interactions, and tissue responses into an overall model of pathogenesis. Improvements in this process will be accomplished in the area of extrapolation modeling (Miller et al., 1983a; Fiserova-Bergerova, 1983). This involves determining the dose delivered to the target organ of various species and the sensitivity of the target organ to that dose. Once such dosimetry has been established and species sensitivity accounted for, the effective pollutant concentration in laboratory animals can be quantitatively related to concentration responses in humans. Extrapolation models should incorporate parameters such as species-specific anatomical and ventilatory differences, metabolic

processes, and the physicochemical properties of the pollutant and should be physiologically based upon the factors that govern transport and removal of the pollutant.

This chapter provides background information on the major determinants controlling comparative inhaled dose that should be considered when evaluating the results of toxicological and human studies for selection of the key studies for the determination of an inhalation reference concentration (RfC). This background information also provides the theoretical considerations that are addressed (to varying degrees) by different dosimetry models, such as those described in Appendices G, I, and J that serve as the basis for the dosimetric adjustments used in Chapter 4 to extrapolate from experimental conditions to human equivalent concentrations. A framework by which to evaluate the degree to which different dosimetry models address these considerations is provided as a summary in Section 3.2.3.

3.1.1 Respiratory Anatomy and Physiology

The respiratory systems of humans and various experimental animals differ in anatomy and physiology in many quantitative and qualitative ways. These variations affect air flow patterns in the respiratory tract, and in turn, the deposition of an inhaled agent, as well as the retention of that agent in the system. The variations in anatomy and physiology will be discussed according to respiratory regions and branching patterns, clearance mechanisms, and cell types. Clearance mechanisms as used here include processes such as the mucociliary escalator, solubilization in various compartments, uptake, and metabolism.

3.1.1.1 Respiratory Regions and Branching Patterns

The respiratory tract in both humans and experimental animals can be divided into three regions on the basis of structure, size, and function: the extrathoracic region (ET) that extends from just posterior to the external nares to just anterior to the trachea, the tracheobronchial region (TB) defined as the trachea to the terminal bronchioles where proximal mucociliary transport begins, and the pulmonary region (PU) including the terminal bronchioles and alveolar sacs. The thoracic (TH) region is defined as the tracheobronchial and pulmonary regions combined. The anatomic structures included in each of these respiratory tract regions are listed in Table 3-1, and Figure 3-1 provides a diagrammatic

TABLE 3-1. RESPIRATORY TRACT REGIONS

Region	Anatomic Structure	Other Terminology
Extrathoracic (ET)	Nose	Head airways region
	Mouth	Nasopharynx (NP)
	Nasopharynx	Upper respiratory tract (URT)
	Oropharynx	
	Laryngopharynx	
	Larynx	
Tracheobronchial (TB)	Trachea	
	Bronchi	
	Bronchioles (to terminal bronchioles)	
Pulmonary (PU)	Respiratory bronchioles	Gas exchange region
	Alveolar ducts	Alveolar region
	Alveolar sacs	
	Alveoli	

Adapted from: Phalen et al. (1988).

representation. The retained dose of an inhaled agent in each of these regions is governed by the exposure concentration, by the individual species anatomy (e.g., airway size and branching pattern) and physiology (e.g., breathing rate and clearance mechanisms), and by the physicochemical properties (e.g., particle size, solubility, reactivity) of the chemical as discussed in Section 3.1.2.

In general, laboratory animals have much more convoluted nasal turbinate systems than do humans, and the length of the nasopharynx in relation to the entire length of the nasal passage also differs between species. This greater complexity of the nasal passages, coupled with the obligate nasal breathing of rodents, is generally thought to result in greater deposition in the upper respiratory tract (or ET region) of rodents than in humans breathing orally or even nasally (Dahl et al., 1991a), although limited data are available. The extent of upper respiratory tract removal affects the amount of particles or gas available to the distal respiratory tract.

Airway size (length and diameter) and branching pattern affect the aerodynamics of the respiratory system in the following ways:

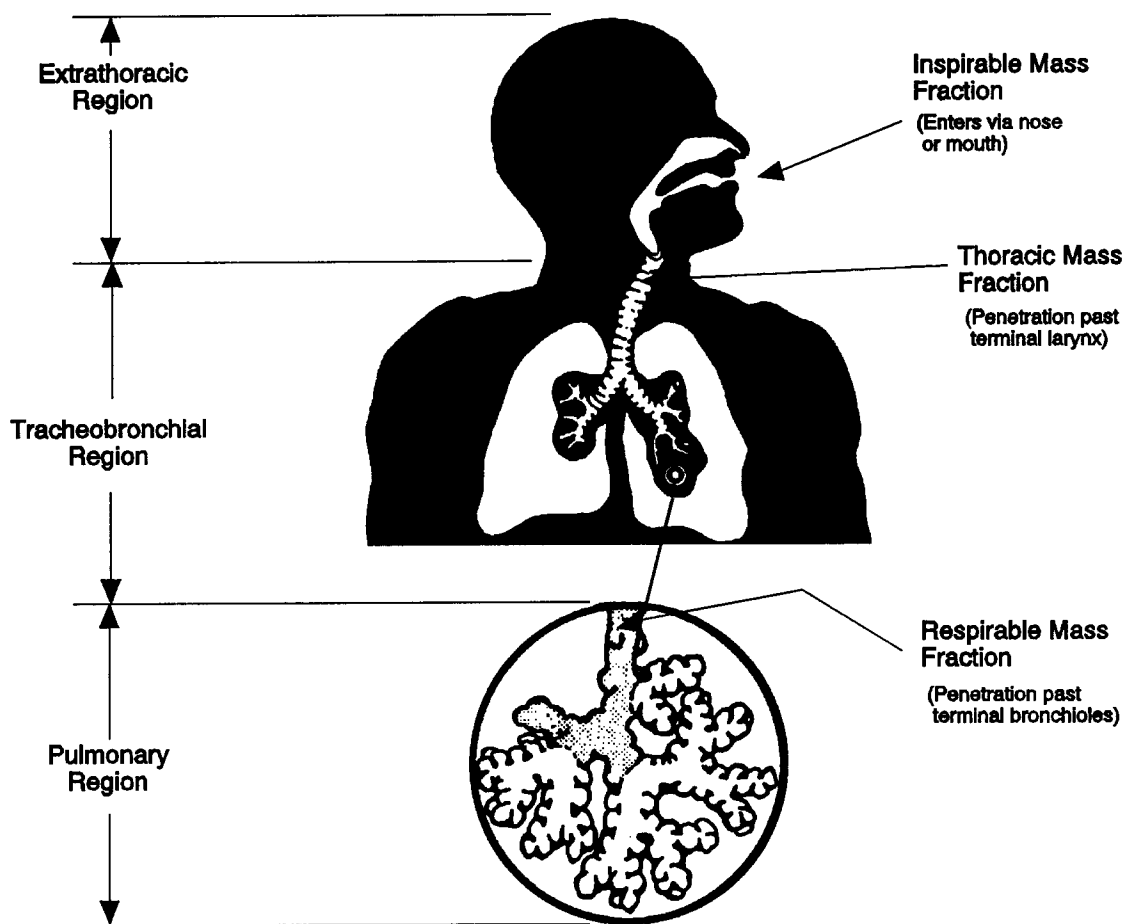

Figure 3-1. Diagrammatic representation of three respiratory tract regions.

- The airway diameter affects the aerodynamics of the air flow and the distance from the agent molecule or particle to the airway surface.
- The cross-sectional area of the airway determines the airflow velocity for a given volumetric flow.
- Airway length, airway diameter, and branching pattern variations affect the mixing between tidal and reserve air.

Differences in airway sizes and branching among species therefore may result in significantly different patterns of transport and deposition for both particles and gases. Alveolar size also differs between species, which may affect deposition efficiency due to variations on the distance between the airborne particle or molecule and alveolar walls (Dahl et al., 1991a).

Effect on Particle Deposition Mechanisms

Air flow in the extrathoracic region is characterized by high velocity and abrupt directional changes. Therefore, the predominant deposition mechanism in the ET region is inertial impaction. In this process, changes in the inhaled airstream direction or magnitude of air velocity streamlines or eddy components are not followed by airborne particles because of their inertia. Large particles ($> 5 \mu\text{m}$ in humans) are more efficiently removed from the airstream in this region.

Impaction remains a significant deposition mechanism for particles larger than $2.5 \mu\text{m}$ aerodynamic equivalent diameter (d_{ae}) in the larger airways of the TB region in humans and competes with sedimentation, with each mechanism being influenced by mean flow rate and residence time, respectively. As the airways successively bifurcate, the total cross-sectional area increases. This increases airway volume in the region, and the air velocity is decreased. With decreases in velocity and more gradual changes in air flow direction as the branching continues, there is more time for gravitational forces (sedimentation) to deposit the particle. Sedimentation occurs because of the influence of the earth's gravity on airborne particles. Deposition by this mechanism can occur in all airways except those very few that are vertical. For particles $\approx 4 \mu\text{m } d_{ae}$, a transition zone between the two mechanisms, from impaction to predominantly sedimentation, has been observed (U.S. Environmental Protection Agency, 1982b). This transition zone shifts toward smaller particles for nose breathing.

Differences in airway size and branching pattern are a major source of interspecies variability in inhaled dose for the TB region. Larger airway diameter results in greater turbulence for the same relative flow velocity (e.g., between a particle and air). Therefore, flow may be turbulent in the large airways of humans, whereas for an identical flow velocity, it would be laminar in the smaller experimental animal. Relative to humans, experimental animals also tend to have tracheas that are much longer in relation to their diameter. This could result in increased relative deposition in humans because of the increased likelihood of laryngeal jet flow extending into the bronchi. Human airways are characterized by a more symmetrical dichotomous branching than that found in most laboratory mammals, which have highly asymmetrical airway branching (monopodial). The more symmetrical dichotomous pattern in humans is susceptible to deposition at the carina because of its exposure to high air

flow velocities toward the center of the air flow profile. These comparative airway anatomy differences are summarized in Table 3-2.

Sedimentation becomes insignificant relative to diffusion as the particles become smaller. Deposition by diffusion results from the random (Brownian) motion of very small particles caused by the collision of gas molecules in air. The terminal settling velocity of a particle approaches 0.001 cm/s for a unit density sphere with a physical diameter of 0.5 μm , so that gravitational forces become negligible at smaller diameters. The main deposition mechanism is diffusion for a particle whose physical (geometric) size is $<0.5 \mu\text{m}$. Impaction and sedimentation are the main deposition mechanisms for a particle whose size is greater than 0.5 μm . Hence, $d_{ae} = 0.5 \mu\text{m}$ is convenient for use as the boundary between the diffusion and aerodynamic regimes. Although this convention may lead to confusion in the case of very dense particles, most environmental aerosols have densities below 3 g/cm^3 (U.S. Environmental Protection Agency, 1982b). Diffusional deposition is important in the small airways and in the PU region where distances between the particles and airway epithelium are small. Diffusion has also been shown to be an important deposition mechanism in the ET region for small particles (Cheng et al., 1988, 1990).

These mechanisms for particle deposition in the respiratory tract are schematically represented in Figure 3-2. Experimental deposition data and extrapolated estimates on humans that illustrate these same concepts are shown by the curves for PU (alveolar) and TB deposition in Figure 3-3. Deposition fraction is shown plotted against particle diameter. It is important to note that over half of the total mass of a typical ambient mass distribution would be deposited in the ET region during normal nasal breathing, with most of this being coarse particles (U.S. Environmental Protection Agency, 1986c). With mouth-only breathing, the regional deposition pattern changes dramatically compared to nasal breathing, with ET deposition being reduced and both TB and PU deposition enhanced. Oronasal breathing (partly via the mouth and partly nasally), however, typically occurs in healthy adults while undergoing moderate to heavy exercise. Therefore, the appropriate activity pattern of subjects for risk assessment estimation remains an important issue. Miller et al. (1988) examined ET and thoracic deposition as a function of particle size for ventilation rates ranging from normal respiration to heavy exercise. A family of estimated deposition curves were generated as a function of breathing pattern. Anatomical and functional differences

TABLE 3-2. COMPARATIVE LOWER AIRWAY ANATOMY AS REVEALED ON CASTS

Mammal/ Body Mass	Gross Structure				Typical Structure (Generation 6)			
	Left Lung Lobes	Right Lung Lobes	Airway Branching	Trachea length/diameter (cm)	Major Airway Bifurcations	Average Branch Angles Airway (Major Daughter/ L/D Minor Daughter) (ratio)	Typical Number of Branches to Terminal Bronchiole	Respiratory Bronchioles
Human/70 kg	Upper and lower	Upper, middle, and lower	Relatively symmetric	12/2	Sharp for about the first 10 generations, relatively blunt thereafter	2.2	11/33	14-17 About 3-5 orders
Rhesus monkey/2 kg	Superior, middle, and inferior	Superior, middle, and inferior, azygous	Monopodial	3/0.3	Mixed blunt and sharp	2.6	20/62	10-18 About 4 orders
Beagle dog/10 kg	Apical, intermediate, and basal	Apical, intermediate, and basal	Strongly monopodial	17/1.6	Blunt tracheal bifurcation, others sharp	1.3	8/62	15-22 About 3-5 orders
Ferret/0.61 kg	NR ^a	NR	strongly monopodial	10/0.5	Sharp	2.0	16/57	12-20 About 3-4 orders
Guinea pig/1 kg	Superior and inferior	Superior, middle, and inferior	Monopodial	5.7/0.4	Very sharp and high	1.7	7/76	12-20 About 1 order
Rabbit/4.5 kg	Superior and inferior	Cranial, middle, caudal, and postcaval	Strongly monopodial	6/0.5	Sharp	1.9	15/75	12-20 About 1-2 orders
Rat/0.3 kg	One lobe	Cranial, middle, caudal, and postcaval	Strongly monopodial	2.3/0.26	Very sharp and very high throughout lung	1.5	13/60	12-20 Rudimentary
Golden hamster/0.14 kg	Superior and inferior	Cranial, middle, caudal, and postcaval	Strongly monopodial	2.4/0.26	Very sharp	1.2	15/63	10-18 About 1 order

^aNR = Not reported.
Source: Phalen and Oldham (1983); Patra (1986); Crapo (1987).

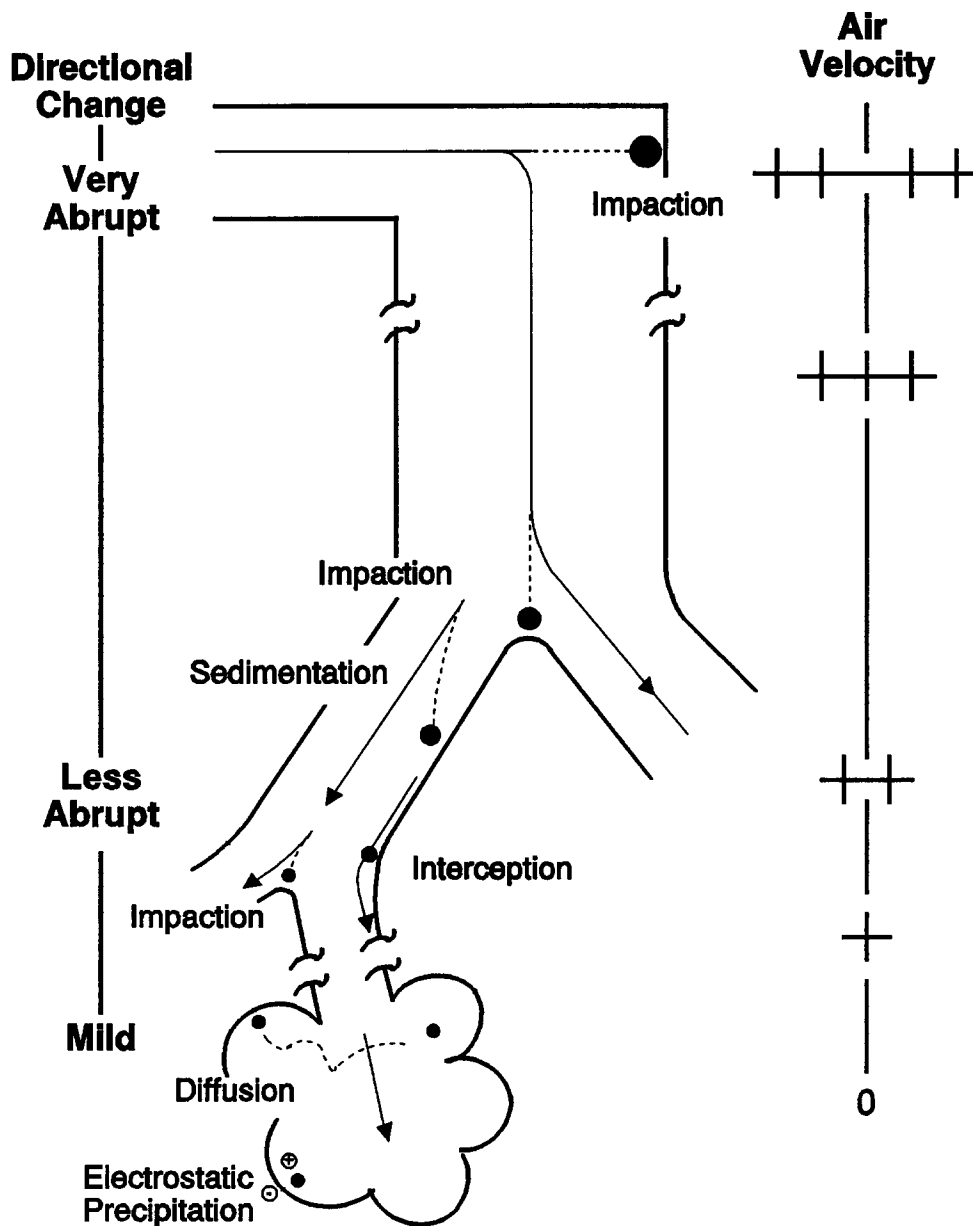

Figure 3-2. Schematic representation of selected parameters influencing regional deposition of particles in the respiratory tract.

Source: Adapted from Casarett (1975); Raabe (1979); Lippmann and Schlesinger (1984).

between adults and children are likely to yield complex interactions with the major mechanisms affecting respiratory tract deposition, again with implications for risk assessment. Age-dependent dosimetric adjustments may be possible, pending data availability for children.

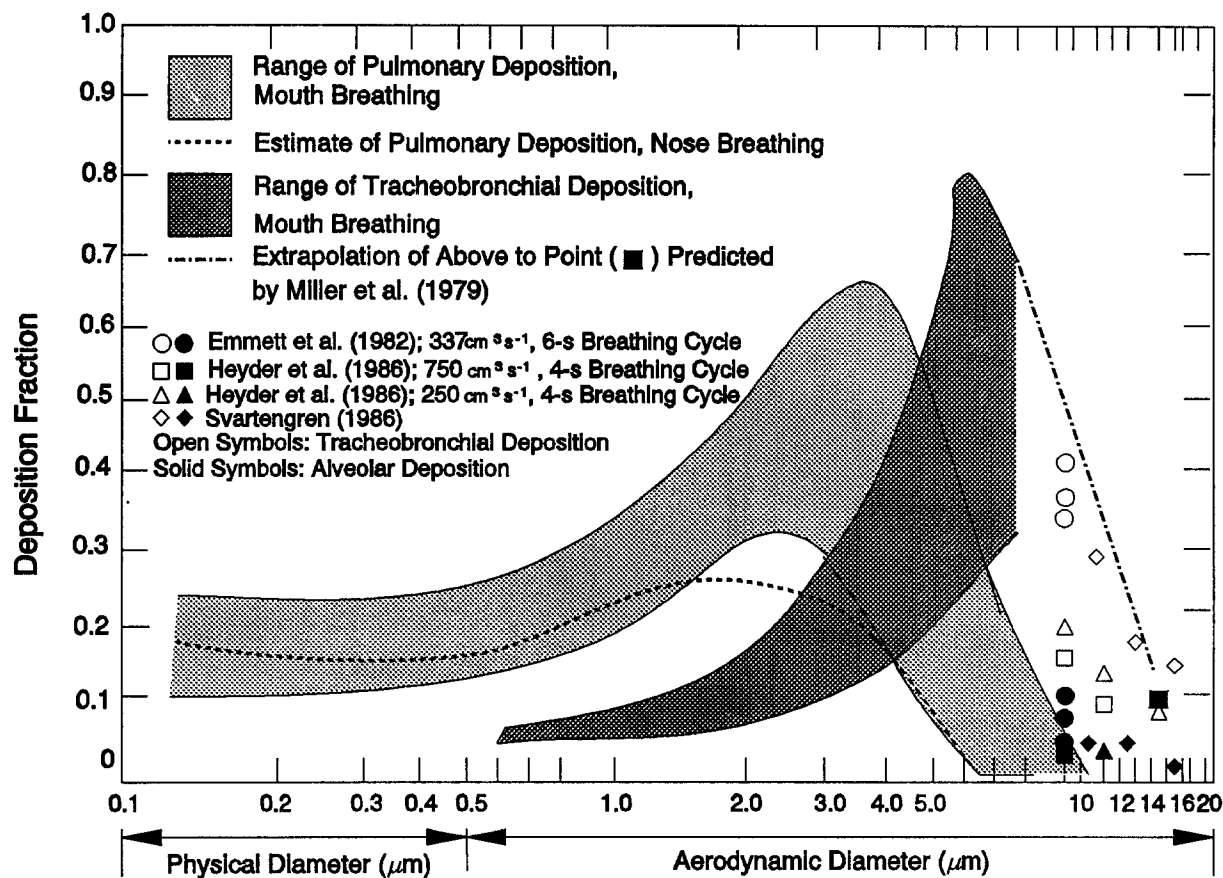

Figure 3-3. Regional deposition in humans of monodisperse particles by indicated particle diameter for mouth breathing (pulmonary and tracheobronchial) and nose breathing (pulmonary). Deposition is expressed as fraction of particles entering the mouth or nose. The PU band indicates the range of results found by different investigators using different subjects and flow parameters for PU deposition following mouth breathing. The TB band indicates intersubject variability in deposition over the size range measured by Chan and Lippmann (1980). The extrapolation of the upper bound of the TB curve in the larger particle size range also is shown and appears to be substantiated by data listed in the legend.

Source: U.S. Environmental Protection Agency (1986c).

Effect on Gas Deposition and Uptake

The major processes affecting gas transport involve convection, diffusion, absorption, dissolution, and chemical reactions. These mechanisms are schematically represented in Figure 3-4. Predictions of lower respiratory tract distribution of ozone from a detailed dosimetry model that accounts for many of these processes is shown in Figure 3-5.

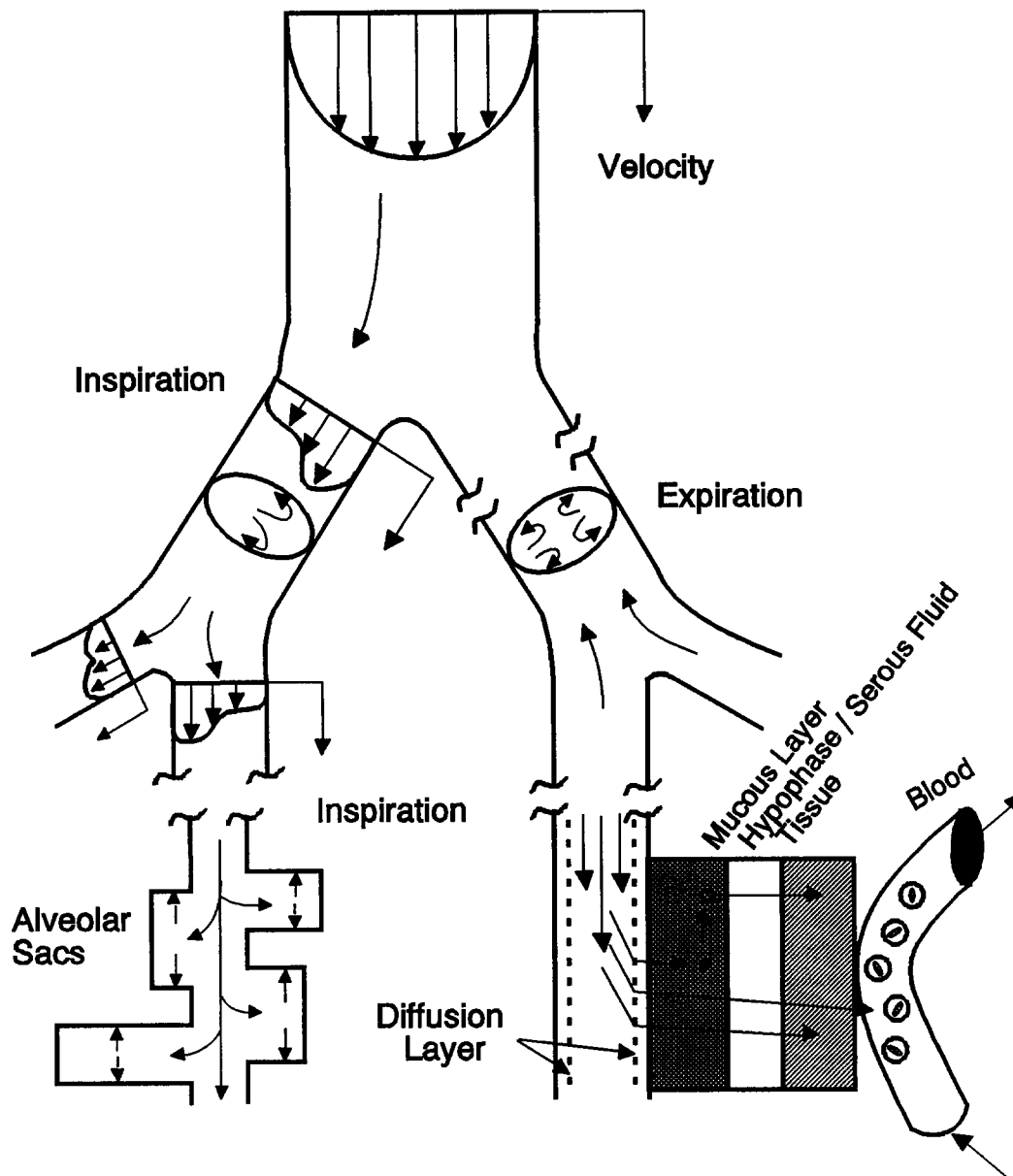

Figure 3-4. Schematic representation of selected parameters influencing regional deposition of gases in the respiratory tract.

Source: Overton (1984).

Beginning at the trachea, the model predicts the net ozone dose (flux to air-liquid interface) slowly decreases distally in the tracheobronchial region and rapidly decreases in the pulmonary region (U.S. Environmental Protection Agency, 1993b).

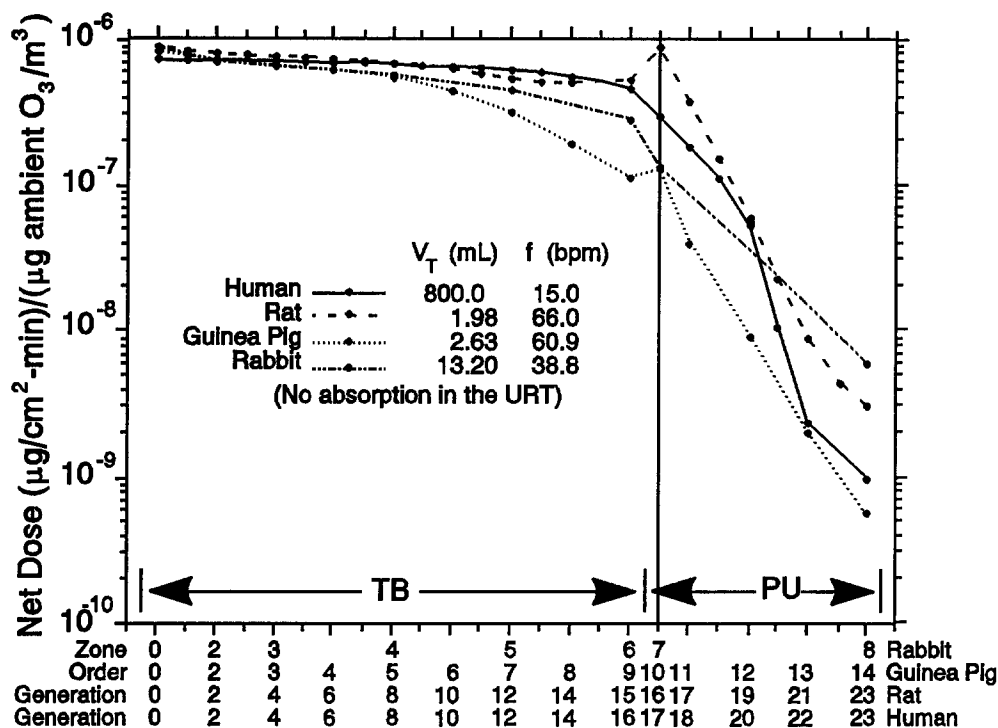

Figure 3-5. Net dose of ozone versus sequential segments along anatomical model lower respiratory tract paths for human, rat, guinea pig, and rabbit. In general, each segment represents a group of airways or ducts, with common features as defined by the designers of the anatomical model (human and rat: generation; guinea pig: order; rabbit: zone). For a given species the plotted dots represent a predicted dose that corresponds to a given segment. The dots have been joined by lines for ease of interpreting the plots; these lines do not represent predicted values except where they intercept the dots. TB = tracheobronchial region. PU = pulmonary region.

Source: Overton and Miller (1988).

The bulk movement of inspired gas in the respiratory tract is induced by a pressure gradient and is termed convection (U.S. Environmental Protection Agency, 1982b).

Convection can be broken down into components of advection (horizontal movement of a mass of air relative to the airway wall) and eddy dispersion (air mixing by turbulence so that individual fluid elements transport the gas and generate flux). Molecular diffusion is superimposed at all times on convection (bulk flow) due to local concentration gradients. Absorption removes gases from the lumen and affects concentration gradients.

The average concentration of a gas in a tube (i.e., an "idealized" airway) can be described by one-dimensional convection and dispersion. A pulse of substance moves down a tube with an average air velocity equal to the medium's (air's) average velocity, and its spread in the axial direction is governed by an effective dispersion coefficient that can be described by Fick's law of diffusion (Overton, 1984). This effective dispersion coefficient is larger than the molecular diffusion coefficient except in the PU region. As illustrated in Figure 3-4, perpendicular transport in this region can carry a gas molecule into the alveoli, but because of the alveolar walls, there is minimal net axial transport with respect to that in the central channel. The average axial transport is slowed because only a fraction of the molecules in the cross-sectional average can move axially, generally resulting in a dispersion process with a dispersion coefficient less than the molecular diffusion coefficient, although it is possible for longitudinal mixing to be enhanced by the presence of alveolar septa leading to dispersion coefficients that are actually greater than the molecular diffusivity (Federspiel and Fredberg, 1989). The dispersion coefficient is a function of the molecular diffusion coefficient, the total air volume, and the generation's alveolar airspace volume (Overton, 1984). The dispersion coefficient is also influenced by the absorption process (Dayan and Levenspiel, 1969).

Molecules are transferred from the flowing gas into the liquid layer lining the airway wall by molecular diffusion. A simple description for this process postulates a thin, stagnant air layer based on the assumption that the air velocity becomes very small as the air-liquid interface is approached. Transfer through this layer depends on the gas-phase diffusion coefficient, layer thickness, and the gas concentrations at the boundaries of the layer. If the molecules are absorbed, then the concentration of the gas in the diffusion layer is decreased at the liquid boundary. As the ability of the liquid to remove the gas increases, the relative concentration at the gas-liquid boundary decreases, and the mass transfer from the gas phase to the liquid phase increases. For poorly soluble, hydrophobic, and nonreactive gases, little gas is removed by the airways. The transport into and chemistry of the adjacent surface liquid and tissue layers will be described in Section 3.1.2.2, which describes the physicochemical characteristics of gases and vapors. These next layers can serve as a "sink" to help "drive" the delivery of gas across this layer. Capillary blood flow (i.e., perfusion) is important to the gas uptake in that it removes the gas or its chemical reaction products on the

other side of these liquid and tissue layers. Therefore, addressing species differences in alveolar ventilation, regional perfusion rates, and cardiac output is critical to estimating initial absorbed dose. The importance of regional differences (e.g., the distance from the air to the capillaries in the tracheobronchial region is 7 to 20 times that in the pulmonary region [Overton and Miller, 1988]) and interspecies differences in the anatomic relationship of the airspace to capillary blood should be considered. Transfer also is enhanced by a reduction in diffusion layer thickness that is dependent on the nearby rate of airflow; the higher the flow velocity, the thinner the layer, again emphasizing the significance of airway morphology.

Although the preceding figures have only illustrated these concepts for the lower respiratory tract, the influence of anatomy on comparative deposited dose is also important in the ET region. Species differences in gross anatomy, nasal airway epithelia (e.g., cell types and location) and the distribution and composition of mucous secretory products have been noted (Harkema, 1991; Guilmette, 1989). The geometry of the upper respiratory tract exhibits major interspecies differences (Gross and Morgan, 1992). Figures 3-6 and 3-7 show diagrams of the ET region that illustrate the differences between Rhesus monkeys and F344 rats. Cross-sections for the four levels shown on the transverse section are at comparable locations in the monkey and rat. Figure 3-8 shows the influence these differences have on airflow patterns in the region. In both species shown in Figure 3-8, studies have demonstrated complex inspiratory flow streams, exhibiting regions of simple laminar, complex secondary (vortices, eddies, swirling), and turbulent flows (Morgan et al., 1991). Differences in nasal air flow patterns between these two species and humans (Hahn et al., 1993) is an important consideration for extrapolation of dose associated with nasal toxicity. Good correlation has been shown between routes of flow, regional secondary flows, turbulence, and impaction of airstreams on the airway wall, with the reported distribution of formaldehyde-induced nasal lesions in these species, illustrating the influence of the nasal anatomy on gas deposition for this reactive and soluble gas (Morgan et al., 1991; Kimbell et al., 1993).

In order to model the effects that the intricate morphological structure of the respiratory tract have on the nature of gas mixing and flows, representations of the mechanical mixing imparted by tube bifurcations, turbulence, and secondary flows due to molecular diffusion must be formulated. Location, diameter, and length of airways are considered to be the

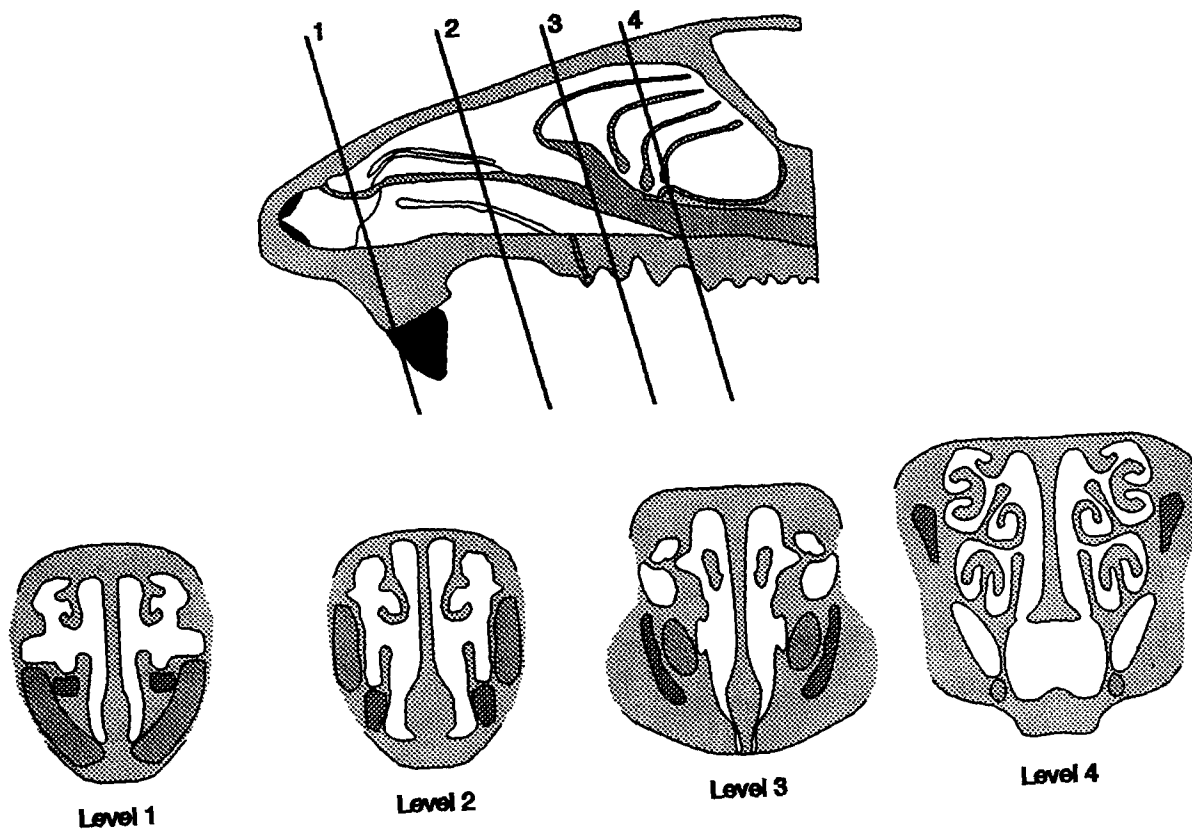

Figure 3-6. Diagram of the nasal passages for the F344 rat modified from Morgan et al. (1984). Cross-sections are shown at the four levels indicated and correspond to comparable locations for the rhesus monkey illustrated in Figure 3-7. Note the greater complexity of the posterior (ethmoid) region of the rat nose compared to that of the monkey. Much of this region is covered by olfactory epithelium, reflecting the macrosmatic nature of rodents.

relevant measurements for gas transport (Overton, 1984). Because of the morphology of the respiratory tract and air flow patterns, the relative contribution of these gas transport processes is a function of location in the respiratory tract and point in the breathing cycle (i.e., depth and rate) (U.S. Environmental Protection Agency, 1982b; Overton, 1984). The interspecies differences in the nature and structure of the respiratory tract, as summarized in Table 3-2, critically influence the differences in transport and deposition of gases across

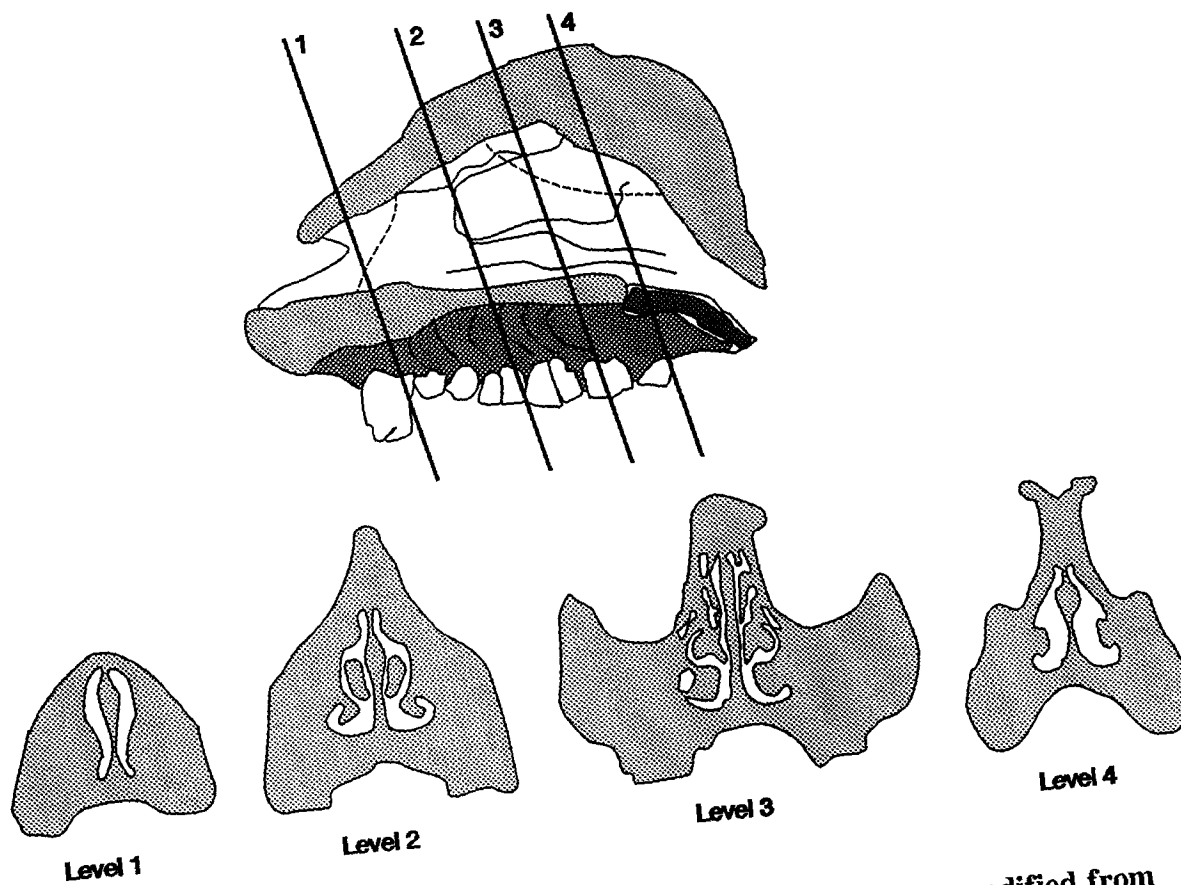

Figure 3-7. Diagram of the nasal passages for the Rhesus monkey modified from Monticello et al. (1989). Broken lines on the transverse section indicate the junction of squamous with the transitional/respiratory (anterior line) epithelia and the respiratory with the olfactory epithelium (dorsal line). Cross sections are shown at the four levels indicated and correspond to comparable locations for rat illustrated in Figure 3-6.

species. The airways also show a considerable degree of within species size variability and this is most likely the primary factor responsible for the deposition variability seen within single species (Schlesinger, 1985). Sex also influences airway anatomy. Additionally, age has dramatic influences on respiratory dynamics.

The differences in respiratory tract anatomy summarized in this Section 3.1.1 are the structural basis for the species differences in gas and particle deposition. In addition to the structure of the respiratory tract, the regional thickness and composition of the airway epithelium (a function of cell types and distributions) is an important factor in gas absorption

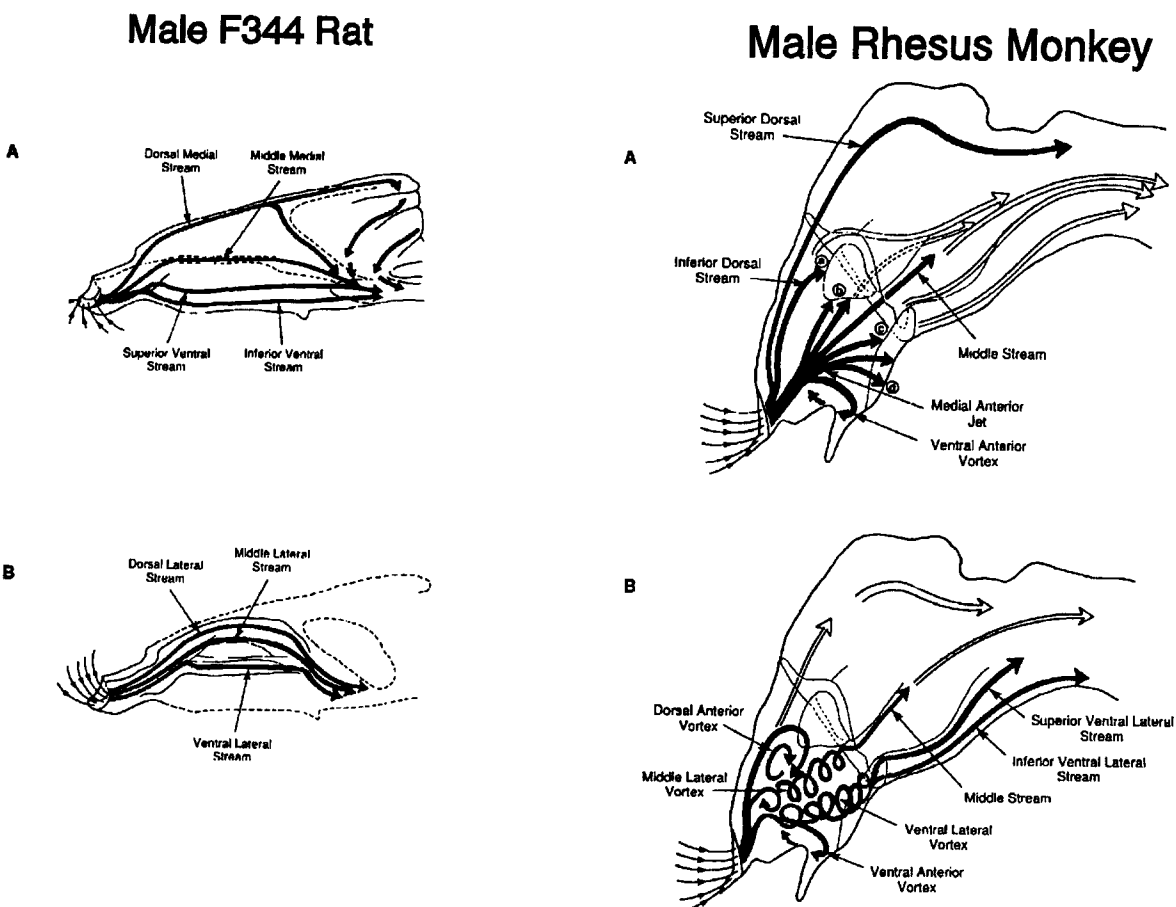

Figure 3-8. Inspiratory airflow patterns in upper respiratory tract of F344 rat and Rhesus monkey. A = major medial streams; B = major lateral streams. Black and white arrows depict high and low velocity airstreams, respectively.

Source: Morgan et al. (1991).

and contributes to the solubility and extent of reaction of the gas. Other anatomic and physiologic factors that influence gas uptake include (1) ventilation, which affects the tidal volume and ventilation to perfusion ratios; (2) body build, which affects the volume of distribution (including cardiac output and tissue volume); and (3) metabolic capacities. These are all factors to evaluate when estimating inhaled dose, interpreting injury response, and extrapolating effects between species.

3.1.1.2 Clearance Mechanisms

Deposited material is removed from the respiratory tract by clearance mechanisms, which vary depending on the site of deposition and the properties of the inhaled toxicant. The speed and efficiency by which the inhaled toxicants are cleared can be critical determinants of their toxic potential. Rapid removal lessens the time available to cause critical damage to the respiratory tract tissue and to permit systemic absorption of agents that have target organs other than the respiratory tract (Menzel and Amdur, 1986). The clearance mechanisms involved include (1) exhalation of volatiles; (2) mucociliary transport; (3) macrophage phagocytosis; (4) chemical reactions; (5) metabolism by various cell types; and (6) dissolution and absorption into the blood, lymphatic, or lung fluids.

Inhalation represents a route of exposure in which a variety of interrelated factors influence not only the nature of the effects (respiratory versus systemic) but also the manner by which they occur. The influence of target cell populations in the respiratory tract on the nature of the response is a factor unique to the inhalation route of exposure. Unlike the liver, a first-pass organ in oral exposures that has a more homogenous population of limited types of cells, the respiratory tract has more than 40 cell types (Sorokin, 1970). Xenobiotics, which exert their action by direct effects of the parent compound or by metabolites, can manifest profound differences in the nature and degree of response, depending on the route of exposure and subsequent availability to interact with various cell populations.

The likelihood of adverse effects in the respiratory tract can be affected by (1) production, distribution, and reactivity of metabolites by and among specific cell types; (2) the degree to which detoxication systems are overwhelmed (e.g., glutathione depletion); (3) efficiency and sensitivity of repair processes (e.g., type II cell proliferation); (4) efficiency of clearance processes; (5) airway mechanics; and (6) mechanism of action (e.g., pharmacologic or immunologic) (Bond, 1989; Boyd, 1980; Calabrese, 1983; Gram et al., 1986; Trush et al., 1982; Nadel et al., 1986; Marin, 1986).

Exhalation of volatile agents (including from administration routes other than inhalation) is an important excretory pathway that is dependent on tissue levels and exposure regimen. For inhalation exposures, the exposure duration influences the amount of chemical entering the systemic circulation, the amount metabolized, and the concentration of the chemical in tissues. Using a simulation model, Fiserova-Bergerova et al. (1984) demonstrated that for

chemicals that are not metabolized, tissue concentrations of "poorly soluble" ($H_{\text{oil/gas}} < 10$) chemicals change very minimally after 2 h of exposure. The pulmonary uptake rate approaches zero at the end of a 2-h exposure and apparent equilibrium is established. "Easily soluble" chemicals ($10 \leq H_{\text{oil/gas}} \leq 10,000$) require more than 1 day of exposure to reach apparent equilibrium and "highly soluble" chemicals ($H_{\text{oil/gas}} > 10,000$) require more than 1 year of exposure. If the chemical is metabolized, pulmonary uptake and the amount metabolized increase with exposure duration, but the effect of metabolism may be more complex if exposure concentrations are so high that metabolic pathways approach saturation kinetics and cause metabolism to deviate from first order kinetics.

Conversely, pulmonary clearance decreases with increasing biosolubility (refers to solubility of gases and vapors in biologic materials) and thereby affects the accumulation of chemicals during intermittent exposure regimens. Simulation of an 8 h/day, 5 days/week schedule for a 3-week exposure duration to a 70 kg man showed that poorly soluble chemicals (as defined previously) have no tendency to accumulate in the body, although easily and highly soluble chemicals do have a tendency to accumulate because the intermissions between exposures are not long enough to allow the chemical to be removed from adipose tissue (Fiserova-Bergerova et al., 1984). Excursions in exposure concentrations had a great effect on tissue concentrations of poorly soluble chemicals, but had little effect on tissue concentrations of highly soluble chemicals. Concentrations in well-perfused tissues were more affected by excursions in exposure concentrations than concentrations in muscle or adipose tissues.

The results of these simulation efforts emphasize the uncertainty that the dual function (i.e., uptake and exhalation) of the respiratory system adds to any attempt to estimate either respiratory tract or extrapulmonary (remote) "dose" of volatile agents. These simulations also emphasize the need for careful consideration of the uptake, metabolism, and excretion parameters for these agents when attempting the exposure duration and concentration conversions discussed in Chapter 4, and when ruling out the possibility of a respiratory tract endpoint when using oral data as part of the data base.

There are numerous defense systems that protect the respiratory tract. While some defense systems are truly protective, it must be kept in mind that many "activate" inhaled agents and may be responsible for adverse effects. Defense systems can be physical in nature

(e.g., filtration of particles by nasal hair), mechanical (e.g., expiration), enzymatic, or cellular (e.g., phagocytosis).

Nasal hair can be envisioned as a first line of defense since it can help prevent contact of toxicants (e.g., particles) with underlying epithelia. However, trapping of agents in the diffusion layer underlying cilia in the nose can serve as a source of irritation and more serious adverse effects. Some agents (e.g., formaldehyde, acrolein) have been shown to cause severe lesions in nasal epithelial cells (Morgan et al., 1986). The mouth also can be envisioned as another first-line defense system. Mouth-breathing in humans can result in solubilization of vapors in saliva and deposition of particles. Swallowing can reduce pulmonary exposure but increase presentation of the agent systemically via gastrointestinal tract absorption. Once an agent penetrates to the tracheobronchial region, agent deposition and/or solubilization occurs in the mucous blanket covering the surface epithelium.

Deposited particles can be cleared from the respiratory tract completely or they may be translocated to other sites within this system. Clearance mechanisms are regionally distinct, in terms of both routes and kinetics (Dahl et al., 1991a). Particles deposited on the anterior nares are cleared by mechanical processes such as nose wiping, blowing (humans), or sneezing (animals/humans). Particles in this area can have long biological half-lives. Those deposited in the nasopharynx or oropharynx, however, are swallowed within minutes and passed through the esophagus down to the gastrointestinal tract.

Particles deposited in the TB region are transported out of the respiratory tract by the mucociliary system, an interaction between the mucous secretions and the cilia that provide the mechanisms of movement. Such transport occurs along the area from the larynx to the terminal bronchioles. Insoluble particles are transported up to the esophagus where they are swallowed. Soluble particles may dissolve in the mucus. Generally, the biological half-lives of insoluble particles deposited in the TB region are on the order of hours.

Clearance of particles from the PU region of the lung generally takes the longest, usually a rapid phase of hours, and slower phases with biological half-lives of days, months, or years, depending on particle size and solubility. A major clearance process for "insoluble" particles is phagocytosis by alveolar macrophages. These cells then may be removed from the PU region after reaching the distal terminus of the mucociliary transport system or by migrating through the interstitium to the lymphatic system. Highly soluble particles will

dissolve in alveolar lining fluid and enter the blood or lymph directly (Johanson and Gould, 1977; Dahl et al., 1991a).

It is likely that dissolution rates and rates by which dissolved substances are transferred into blood are related mostly to the physicochemical properties of the material being cleared and are essentially independent of species. On the other hand, different rates of mucociliary transport in the conducting airways or of macrophage-mediated clearance from the PU region may result in species-dependent rate constants for these pathways (Dahl et al., 1991a). For example, clearance of insoluble particles from the PU region of mice and rats is much faster than that in dogs and humans, which have similar clearance rates of inhaled particles (Snipes, 1989a,b).

As discussed in Chapter 2, an overload phenomenon can occur with excessive particle exposures that can alter the clearance kinetics of lung dust burdens and confound the interpretation of toxicological effects (Morrow, 1992).

Conceptually, uptake of a gas requires that it move from the airway lumen through the surface-liquid lining layer, the tissue layer, and the capillary endothelium, to reach the blood. This passage is influenced by the physiochemical properties of the gas as well as the biochemistry and thickness of the layers between the lumen and blood. For reactive gases, the sequence in which anatomic sites are affected appears to be more dependent on concentration than on exposure duration. However, at a given local anatomic site and at a specific concentration, the stages in the pathogenesis of the lesion relate to the duration of exposure (U.S. Environmental Protection Agency, 1986d, 1993b). The rate of mucous transport also affects the gas transport mechanisms in the diffusion layer at the gas/liquid interface along the airways. The rate varies with the depth of the airways (greater velocities in the proximal airways) and across species. For example, a very highly reactive gas may not reach the blood if it reacts biochemically with mucus and the mucus layer has sufficient volume (thickness) to serve as a sink. This same gas may not react with the saturated lipid of surfactant; and if deposited significantly in the PU region, could reach alveolar tissue. The thickness and efficiency of the epithelial barrier also influences absorption. Both of these main factors (liquid lining and epithelial barrier) are present in all species but have species-specific differences, only a few of which have been quantified. Mucus is a complex secretion with contributions from various epithelial cells. The numbers and distribution of

these cells may affect the composition and properties of the mucus, which in turn interacts with the physicochemical properties of the agent. The species differences in the thickness of the alveolar epithelial cells could account for variations observed in the diffusion of gases into the bloodstream (Crapo et al., 1983). The lung also is a very efficient excretory organ for volatile organic chemicals after the exposure ceases or is lowered. The efficacy of PU excretion correlates directly with the saturated vapor pressure of the chemical and indirectly to water solubility.

Cell Types

A variety of other cellular defense mechanisms can be marshaled, which can diminish or sometimes exacerbate toxic insult. The numerous cell types found in different species contribute to the varying clearance patterns from the respiratory regions and differences in the nature of the response. Table 3-3 presents the distributions of various cell types across species commonly used in inhalation toxicologic investigations. Different mammalian species have different amounts and isozyme distribution of cytochrome P-450 in their Clara cells, which could account for differences in metabolism of some agents. Recent investigations have also shown species differences in cellular organization at the terminal respiratory bronchioles/alveolar duct junctions and in the ultrastructure of the same cell type across species (St. George et al., 1988). The possible functions of these cell types are provided in Table 3-4, and the differences seen in the cell types across species are summarized in Table 3-5. Such species differences are important to consider when determining if the laboratory animal is an appropriate model for the chemical's mechanism of action. For example, the rat may be an inappropriate species for the evaluation of hypersensitivity because of its lack of mast cells.

Alveolar macrophages are the predominant cell type responsible for clearance of particles from the PU region. Particles are phagocytized and transported within macrophages to the mucociliary escalator. This alveolar macrophage clearance of the PU region is considerably slower (weeks to years) than clearance in the TB region. Gases and soluble particles that escape phagocytosis by alveolar macrophages can be dissolved in the lining fluid. This dissolution would be governed by physicochemical characteristics such as

TABLE 3-3. NORMAL SURFACE AIRWAY EPITHELIUM: CELL TYPES

	Guinea									
	Humans	Monkey	Dog	Ferret	Pig	Rabbit	Rat	Hamster	Mouse	
Epithelial										
Ciliated	+	+	+	+	+	+	+	+	+	+
Mucous	+	+	+	+	+	+	+	+	+	+
Serous	a	-	-	-	-	-	b	c	-	-
Clara	+	+	+	+	+	+	+	+	+	+
Endocrine	+	+	-	-	+	+	+	+	+	+
Type I	+	+	+	+	+	+	+	+	+	+
Type II	+	+	+	+	+	+	+	+	+	+
Transitional	d	-	-	-	-	-	e	g	f	f
Special type	h	-	+	-	-	-	-	-	-	-
Brush	-	-	-	+	+	+	+	-	+	+
Intermediate	+	-	+	+	-	-	+	+	+	+
Basal	+	+	+	+	+	+	+	+	+	+
Migratory										
Lymphocyte	+	i	-	-	-	+	+	+	+	+
Globule leukocyte	-	i	i	-	-	-	+	-	-	-
Mast cell	h	+	i	-	+	-	-	-	-	-
Macrophage	+	(+)	+	(+)	(+)	(+)	+	(+)	(+)	(+)
Neural										
Neuroepithelial body	+	+	-	-	-	+	+	-	+	+
Nerve terminals	h	+	-	+	+	+	+	+	+	j

+ = Reported present;
 (+) = Not specifically reported in sources cited;
 - = Unidentified;
 a = Fetal tissue;
 b = In specific pathogen-free rats;
 c = Only young animals;
 d = Ciliomucous, mucoserous, endocrine-mucous;
 e = Seromucous;
 f = Ciliomucous, seromucous;
 g = Ciliomucous;
 h = Not in "normal" biopsy material;
 i = "Migratory cell";
 j = Bronchiolus only.

Source: Jeffery (1983), Crapo et al. (1983).

TABLE 3-4. SOME SPECIFIC LUNG CELL TYPES AND THEIR FUNCTIONS

Cell Types	Location and Function
<u>Epithelium</u>	
Clara cells	Nonciliated cells of the tracheobronchial region; high xenobiotic metabolic activity; secretory; function not well-defined; may serve as precursor of goblet and ciliated cells
Ciliated cells	Most common epithelial cells in airways; may secrete mucous-like substances; controls periciliary fluid
Type II alveolar	Generally covers <5% of alveolar surface; secrete surfactant; replace injured Type I cells; high xenobiotic metabolic activity
Type I alveolar	Large and covers considerable surface area per cell; covers ≥95% of alveolar surface; forms the alveolar epithelium and facilitates gas exchange; low metabolic activity; incapable of self-reproduction
Mucous	Mucus-secreting
Serous	Mucus-secreting; periciliary fluid; stem cell
Brush cells	Chemoreceptor cells; preciliated
Globule leukocyte	Immunoglobulin transportation; releases inflammatory mediators
Endocrine	Secreto- and vaso-regulatory
<u>Submucosal</u>	
Goblet (mucus) cells	Epithelial linings; common in trachea and bronchioles; contribute to mucus production
Serous cells	Mucus-secreting; periciliary fluid; stem cell/proliferative
Endocrine cells	Secretes amines and neuropeptides
Lymphocytes	Immunoresponsive
Myoepithelial	Expulsion of mucus
Bronchoalveolar mast cells	Migratory cells located throughout respiratory tract; release mediators of bronchoconstriction when antigens bind to IgE antibodies on surface
Macrophage	Phagocytic; secrete mediators of inflammatory reactions; modulate lymphocytes and otherwise participate in immune response
Endothelial cells	Approximately 40% of lung parenchyma cells; metabolize blood-borne substances; proliferative
Fibroblasts (interstitial)	Predominant in alveolar wall and constitutes the basement membrane; become activated during disease states and produce elastin and collagen; proliferation leads to fibrosis, modulation of growth, bronchial tone, and mucosal secretion

Source: Jeffery (1983), Bowden (1983), Marin (1986), Nadel et al. (1986), Plopper et al. (1983), Burri (1985), Brain (1986).

**TABLE 3-5. MAIN SPECIES DIFFERENCES IN EPITHELIAL CELLS
AND GLANDS**

Epithelial Morphology

Thickness and pseudostratification
Thickness and structure of "basement membrane"

Mucus-secreting cells

Number
Histochemistry
Predominant ultrastructure type

Clara cells

Morphology (smooth endoplasmic reticulum)
Distribution

Endocrine cell frequency

Ciliated cells

Extent of coverage
Structure of rootlet
Lamellar bodies
Glycogen stores

Presence of brush cell

Basal cells

Number
Shape
Tonofilaments

Presence of Globule Leukocytes

Innervation

Extent
Distribution
Type

Gland Morphology

Amount
Distribution
Main histochemical cell type
Presence of collecting duct
Innervation

Source: Jeffery (1983).

reactivity, water solubility, lipophilicity, and ability to serve as substrate for activation and/or detoxification enzymes.

Certain cell types can be stimulated to release mediators, such as mast cell release of histamine. Histamine can cause bronchoconstriction, which can be protective, by limiting the amount of pollutant inhaled, or can be toxic, by limiting oxygen uptake. Synthesis or metabolism of prostaglandins (leukotrienes) also can affect airway and vascular caliber. The chemotactic factors released can recruit phagocytic cells involved in clearance. It should be recognized that the respiratory tract contains a variety of different cell types that possess different metabolizing potential and are distributed in a manner that varies among species. Lists of common cell types and their functions are provided in Tables 3-3 and 3-4. Macrophages, for example, constitute a cellular protection system and not only protect inner surfaces of the respiratory tract from damage caused by particles and microorganisms, but also have the potential to cause damage themselves because the proteases and mediators that are useful in destroying microbes or physical agents can also destroy healthy tissue (Rossi, 1986) (Brain, 1986). Although recruitment of macrophages to the lung is related to the toxicant dose, the adaptive increase in macrophages can be exceeded (Bowden, 1986). This threshold may vary among species. The alteration of macrophage functioning has the potential to shift the balance between protective and adverse effects.

Epithelial secretions in response to injury may recruit scavenger cells such as polymorphonuclear leukocytes, which can biotransform inhaled agents. More recent data on cellular morphometrics and interspecies differences in cell populations (Mercer and Crapo, 1987; St. George et al., 1988) will aid in dosimetry adjustments for clearance, metabolism, and uptake. As an example, modeling for the metabolic capacity of the human lung instead of considering it only as a physical barrier can result in disparate estimates of extrapulmonary dose (see Section 3.2). Estimates from models that account for respiratory tract metabolism may better fit experimental data on systemic dose surrogates for some chemicals.

Concurrent with the action of inhaled agents upon critical cell types in the respiratory tract, a portion of the dose in the PU region is likely to be transported across the alveolar epithelium and enter systemic circulation. Changes in permeability can result from the action of some of the mediators and proteases mentioned. The greater the amount reaching the systemic circulation, the greater the likelihood for adverse effects in other systems (e.g.,

liver, kidney, central nervous system). The rapidity and extent to which systemic absorption occurs and the time-to-steady-state blood levels are influenced by (1) ventilation rates and airway mechanics, (2) blood transit time in capillary beds (i.e., perfusion limited), (3) metabolic conversion in the respiratory tract and other organs, (4) alveolar surface area, (5) thickness of the air-blood barrier, and (6) the blood:air and blood:tissue partition coefficients. Many of these factors vary among species and, therefore, should be considered in key study identification.

After the inhaled agent enters systemic circulation, the liver may produce additional metabolites that, if the half-life is sufficiently long, may re-enter the lungs and exacerbate the portal-of-entry effects or produce additional adverse effects (Boyd and Statham, 1983; Yost et al., 1989). Some other agents, that do not require bioactivation, have been shown to damage the lung when applied systemically (Kehrer and Kacew, 1985).

Metabolism

The effect of respiratory tract metabolism on the toxicity of inhaled materials is thought to be important for many chemicals because (1) high concentrations of xenobiotic metabolizing enzymes occur in the nose and substantial concentrations occur in the lower respiratory tract; (2) the respiratory tract tissues are the first exposed to inhaled chemicals and are exposed to the highest concentrations (barring tissue-specific uptake); (3) the products of respiratory metabolism may have different toxicities from those of hepatic metabolism; and (4) tissues at risk to toxic metabolites formed in the respiratory tract are different from those formed in the liver (Dahl et al., 1988). The metabolic capacity of the lower respiratory tract has been recognized for many years and nasal metabolism has recently been shown to be significant for some compounds (Dahl et al., 1988). Accordingly, it is useful to consider that inhaled chemicals may be extensively metabolized in the nose or in the lower respiratory tract and both the metabolites and the parent compound may be cleared via the blood or by mucociliary clearance.

Metabolism of potentially toxic inhaled compounds is achieved by a variety of enzyme reactions involving oxidation, reduction, hydrolysis, and conjugation. The enzymes may work individually, concurrently, or consecutively to detoxicate or, in some cases, activate inhaled foreign compounds (Ohmiya and Mehendale, 1984; Minchin and Boyd, 1983; Dahl

et al., 1987). These enzymes may vary in activity across species and organs (Ohmiya and Mehendale, 1984; Ziegler, 1980; Tynes and Hodgson, 1985; Plopper et al., 1983; Litterst et al., 1975). Depending on the chemical being metabolized, each of these enzymes may play a role in either an activation or detoxication pathway. The balance between activation and detoxification governs the rate of delivery of bioactive metabolite to the macromolecular target site (Dahl et al., 1991a).

The oxidation and reduction reactions are catalyzed primarily by the cytochrome P-450 and flavin-containing monooxygenases (FAD-MO). The cytochrome P-450 isoenzymes are ubiquitous hemoproteins located in the endoplasmic reticulum of a variety of cells and are responsible for the oxidation of foreign compounds. Isoenzyme specificity, inducibility, catalytic activity, and localization in the rabbit and rat lung (Domin and Philpot, 1986; Vanderslice et al., 1987) have been elucidated. Until recently, it was thought that the cytochrome P-450 isoenzymes were the only primary monooxygenases in the lung. However, recent studies have shown that the FAD-MO play an important role in detoxication of foreign compounds. FAD-MO have also been demonstrated to exist in various isoenzymic forms, with substrate specificity and mechanisms different from those of cytochrome P-450 (Ziegler, 1988).

The Clara cells lining the respiratory and terminal bronchioles are thought to be the primary site of cytochrome P-450 because of the presence of endoplasmic reticulum. However, the ultrastructure of the Clara cell varies across species (Plopper et al., 1980). In the ox, cat, and dog, more than 60% of the cytoplasmic volume is glycogen with a relatively small proportion of the cell volume containing endoplasmic reticulum or mitochondria. Therefore, species differences in Clara cell ultrastructure can be reflected in significant differences in xenobiotic metabolism potential (Plopper et al., 1983; St. George et al., 1988). Differences in localization of cytochrome P-450 activity have been suggested as a likely basis for some differences in respiratory tract toxicity (O'Brien et al., 1985).

Epoxide hydrolases and carboxy esterases are hydrolytic enzymes found in both the nasal cavity and lower respiratory tract tissues. The epoxide hydrolases further metabolize potentially toxic oxidation products after initial cytochrome P-450-dependent metabolism of aromatic compounds or alkenes. The carboxy esterases hydrolyze carboxylic esters to the respective alcohols and carboxylic acids. At least two types of aldehyde dehydrogenases have

been detected in the nasal cavity and may be important in modifying the toxicity of volatile aldehydes such as formaldehyde and acetaldehyde (Casanova-Schmitz et al., 1984). Aldehyde dehydrogenase also occurs in the lower respiratory tract, particularly in the Clara cells of the distal bronchioles.

Individually or in concert with the cytochrome P-450 isoenzymes, conjugation reactions are catalyzed by the glutathione-*S*-transferases that transform potentially toxic parent compounds or activated metabolites into nontoxic water soluble compounds. The glutathione-*S*-transferases may catalyze conjugation reactions with toxic metabolites formed by the cytochrome P-450, rendering them harmless and easier to excrete from the body. However, GSH conjugation with certain substrates (e.g., 1,2-dibromoethane and several other related haloalkenes) has been shown to provide reactive species capable of producing nephrotoxicity (Monks and Lau, 1989). The cofactor required for these reactions is glutathione (GSH). The GSH is synthesized in the lung, as well as in other major organs, and also is reduced from the oxidized state (GSSG) to the reduced state (GSH) by GSH reductase. Under extreme conditions of GSH depletion in the lung, it has been hypothesized that extrapulmonary GSH is mobilized and transported to the lung from the liver (Berggren et al., 1984). The GSH has been identified in isolated Type II epithelial cells, Clara cells, and ciliated cells of the lung, but it is not known if it is present in all pulmonary cells. The GSH also is the cofactor utilized by the enzyme GSH peroxidase. The GSH peroxidase catalyzes the metabolism of hydrogen peroxide and organic peroxides formed by the ozonization of unsaturated fatty acids. Other key antioxidant components in the lung include ascorbic acid, α -tocopherol, superoxide dismutase, and catalase (Massaro et al., 1988).

3.1.2 Physicochemical Characteristics of the Inhaled Toxicant

The physicochemical characteristics of the inhaled agent will influence the deposition and retention within the respiratory tract, translocation within the respiratory system, distribution to other tissues, and ultimately, the toxic effect. Therefore, it is important to consider characteristics of the inhaled agent as well when attempting to evaluate and extrapolate the effects of a particular exposure.

3.1.2.1 Particles

For a given particle exposure, the two most important parameters determining deposition are the mean diameter and the distribution of the particle diameters. The size, density, and shape of the particles influence their aerodynamic behavior and, therefore, their deposition (Raabe, 1979; U.S. Environmental Protection Agency, 1982b, 1986c). The definition of diameter for a spherical particle is unambiguous, but for irregularly shaped particles, a variety of definitions exist. Nonspherical particle size often is described by its aerodynamic properties. Fibrous material may be described by actual length, actual diameter, coil length, coil diameter, aspect ratio, or coil-to-aspect ratio.

Information about particle size distribution aids in the evaluation of the effective inhaled dose (Hofmann, 1982). Recommendations defining the particle size ranges for inspirability to the various regions have been published by an ad hoc working group of the International Standards Organization (1981). Particle diameter and size distribution should be provided to the risk assessor to completely characterize the aerosol in order to estimate respiratory tract deposition with any confidence and to evaluate relevance to toxicologic potential. Appendix H provides definitions of particle size diameters and distributions. Appendix G presents a dosimetry model that accounts for interspecies differences in regional respiratory tract deposition and illustrates the influence of particle size and distribution on deposition.

3.1.2.2 Gases and Vapors

The deposition site and rate of uptake of a volatile chemical are determined by its reactivity and solubility characteristics. Therefore, the pharmacokinetics of gases and vapors are governed by

- Rate of transfer from the environment to the tissue,
- Capacity of the body to retain the material, and
- Elimination of the parent compound and metabolites by chemical reaction, metabolism, exhalation, or excretion.

As mentioned in Section 3.1.1.1, the transport processes in the liquid and tissue layers adjacent to the airway lumen influence the relationship of the gas with the air-liquid

boundary. Physicochemical characteristics of the gas that contribute to the relative importance of these processes include its chemical reactivity and solubility.

The chemical reactions of the gas with both the liquid and tissue layers may be important. For example, reactions with the liquid layer could result in an increased flux from the airway but reduce (relative to no reactions) the delivery of the gas to the tissue. If the gas is the only toxic molecule, then this reaction would protect the tissue. Conversely, if the reaction products are toxic, then reactions with the tissue layer would increase the delivery of toxic molecules to the tissue (Overton, 1984). Chemical reactivity with the biological constituents of the tissue is similarly important to the gas's toxic potential to the respiratory tract tissue and to the amount of gas and reaction products that enter the blood for potential extrapulmonary toxicity. Theoretically, knowledge of all the chemical species involved and the reaction rates of the reactants and products is necessary to characterize a system for dosimetry. Sometimes the complexities may be reduced into relative classifications (e.g., slow, fast, instantaneous) using approximation techniques for time and spatial dependence (Overton and Miller, 1988).

Gases that are not soluble or reactive are relatively inert to the airways and penetrate to the alveoli. Examples are nitrogen and volatile hydrophobic chemicals. The major factor driving the uptake of these gases is the removal of the gas from alveolar air by capillary blood. The concentration in alveolar air and capillary blood is generally considered to reach equilibrium. Therefore, uptake of alveolar gases depends on blood:air partitioning, ventilation/perfusion ratio, and air and blood concentrations.

For gases that are soluble, uptake is linearly related to solubility (Overton and Miller, 1988). There are many different expressions for the solubility of gases, differing in terms of units as well as in terms of what chemical form of the gaseous species in the liquid phase is related to the gas-phase quantities. As long as the concentration of dissolved gas is small, and the pressure and temperature are not close to the critical temperature and pressure, then Henry's Law is obeyed (Overton and Miller, 1988). It should be noted that the Henry's Law constant is independent of chemical reactions so that it refers to the parent molecular form of the gas in water and air, and not the total quantity absorbed in water to air quantities. Considering the importance of chemical reactions as described above, solubilities as indicated by Henry's Law constants may not be appropriate to fully describe uptake. Further,

extrapolation of Henry's Law constants from water data to biological fluids and tissues is not always appropriate, particularly for organic compounds.

Because uptake and disposition of inhaled vapors and gases are driven by the equilibration of their partial pressures in tissues with their partial pressures in ambient air, solubility may be aptly described by Ostwald solubility coefficients at body temperature. Ostwald solubility coefficients and partition coefficients (concentration ratios of the volatile chemical in two phases with equilibrated partial pressures) have the same values (Fiserova-Bergerova et al., 1984). Partition coefficients are essentially a measure of the affinity of a chemical for one medium compared to another at equilibrium. The blood:air (or blood:gas) partition coefficient is a critical determinant in the uptake and achieved blood concentration of volatile organic chemicals (Dahl et al., 1991a). Absorption generalizations based on molecular weight are not recommended. As an example, the difference in solubility between methanol and ethane, which have similar molecular weights, is a result of the presence of the hydroxyl group on methanol. Interspecies comparisons necessitate consideration of the effects of the differences in anatomy and physiology described previously, but it can generally be stated that the less water soluble and less reactive the gas, the more similar the deposition will be between humans and laboratory animals. The tissue:gas partition coefficient of a chemical has been shown to correlate with its fat:gas and blood:gas partition coefficients so that linear correlation equations may provide a useful means of estimating tissue:gas and blood:gas partition coefficients (Fiserova-Bergerova and Diaz, 1986).

Similarly, the fat:air partition coefficient can serve as an index of whether high concentrations of the chemical will occur in the fat. The fat compartment plays an important role in accumulating and storing lipophilic chemicals both during and after exposure. The chemical stored in fat becomes available for redistribution by the systemic circulation after the end of exposure when the arterial blood concentration decreases relative to the fat. This "postexposure" phenomenon due to fat solubility can be an important factor influencing the amount of chemical metabolized, because that chemical that leaches from the fat compartment after exposure is available for metabolism, which can continue for a significant period of time after removal from the exposure atmosphere. Therefore, interspecies differences in body fat can induce interspecies differences in uptake, distribution, accumulation, and toxicity of lipophilic chemicals.

Metabolism of the parent compound can modulate uptake of inhaled gases from the respiratory tract and is also probably the most important determinant of tissue dosimetry when metabolites are the toxic moiety. The cells and tissues at risk from toxic metabolites depend not only on the source of the metabolites but also on their kinetic properties. The toxic effects of metabolites that react at fast rates are confined to the activating enzyme or cell. If metabolite reaction rates are moderate, effects will largely be restricted to the activating tissue and to nearby tissues. Slow-reacting metabolites may themselves be potential substrates for further metabolism.

The effect of concentration and exposure time on the above parameters of reactivity and metabolism should be addressed. Uncatalyzed reactions follow pseudo-first-order kinetics if the gas is inhaled at "low" concentrations (Overton and Miller, 1988). "High" vapor concentrations can qualitatively change the chemical fate and toxicity. Depletion of biological coreactants, or just an increase in the concentration of the chemical to the point at which reactions can no longer be treated as pseudo-first-order, may qualitatively change the fate and potentially the toxicity of an inhaled gas. For chemicals metabolized according to Michealis-Menten kinetics, metabolism may be saturated at high concentrations and become described by zero-order kinetics. Further, saturation of metabolic pathways can alter the metabolites formed and the resultant toxicity of the metabolized compound.

Such effects of inhaled vapor concentration on metabolism are not limited to systemic enzymes, but also occur in localized areas within the respiratory tract. In general, the concentrations of inhalants in the respiratory tract mucus will be higher than anywhere else in the body, barring selective tissue uptake. Therefore, the xenobiotic metabolizing enzymes of the respiratory tract will reach maximum reaction velocities at inhaled concentrations far lower than those needed to bring extrapulmonary (systemic) enzymes to maximum velocities. Therefore, it is likely (except at extremely low inhaled gas concentrations) that local metabolizing areas within the respiratory tract, particularly the nasal tissues, will not follow linear enzyme kinetics (Dahl, 1990).

The physicochemical gas characteristics of reactivity and solubility will interact with physiologic parameters such as pulmonary ventilation, cardiac output (perfusion), metabolic pathways, tissue volumes, and excretory capacities. The relative contribution or interaction of these is, in turn, affected by the exposure conditions (concentration and duration), so that as

emphasized previously, integration of these various factors is necessary to estimate the deposited (on airway surfaces) and absorbed doses in order to assess toxicity.

3.2 MODELING COMPARATIVE DOSIMETRY OF INHALED TOXICANTS

The preceding discussion provides an overview of the various factors that affect the disposition (deposition, uptake, distribution, metabolism, and elimination) of inhaled toxicants. Major determinants include (1) the respiratory tract anatomy and physiology and (2) the physicochemical characteristics of the inhaled toxicant. The relative contribution of each of these factors is a dynamic relationship. Further, the relative contribution of these determinants is also influenced by exposure conditions such as concentration and duration.

As discussed in Chapter 1, a comprehensive description of the exposure-dose-response continuum is desired for accurate extrapolation from experimental conditions and dose-response assessment. Therefore, an extrapolation model should incorporate all of the various deterministic factors described in the previous section into a computational structure. Clearly, many advances in the understanding and quantification of the mechanistic determinants of chemical disposition, toxicant-target interactions, and tissue responses are required before an overall model of pathogenesis can be developed for a specific chemical. Such data do exist to varying degrees, however, and may be incorporated into less comprehensive models that nevertheless are useful in describing delivered doses or in some cases, target tissue interactions.

Because much information on the mechanistic determinants of target tissue dose, toxicant-target interactions, and tissue responses is likely lacking for any given chemical to which this RfC methodology will be applied, the default dosimetry adjustments are derived from models that incorporate only the major determinants of chemical disposition. The defaults are determined categorically for particles versus gases, and within gases, for those more reactive (defined as including local metabolism) and soluble than nonreactive and insoluble. It is recognized, however, that these are default dosimetry models, so that use of models that incorporate a more comprehensive description of the exposure-dose-response continuum may take precedence when such a model is judged to provide a more accurate

description. The next sections describe the rationale for the default models and dosimetry adjustments provided in detail in Chapter 4 and the Appendices G, I, and J. Examples of more robust models are provided to illustrate considerations of the appropriateness of the default versus alternative model structures. The summary for this section then provides considerations for judgement of the relative value of different modeling structures. This judgment may be based on whether the structure of the alternative model is superior to that of the default, (e.g., incorporates additional known mechanistic determinants) or if it empirically results in a better correlation between "dose" and "effect".

3.2.1 Particle Deposition Model Based on Available Data

The preceding discussion in this chapter described the various mechanisms and anatomical dependencies of deposition in the respiratory tract. A theoretical model to describe deposition would require detailed information on all of these parameters (e.g., exact airflow patterns, complete measurements of the branching structure of the respiratory tract, pulmonary region mechanics) across the various species used in toxicity studies.

As described in Appendix G, an empirical model was instead developed due to the limited availability of these types of data. An empirical model is a system of equations fit to experimental data. Measurement techniques for deposition are such that deposition can be defined only for the major respiratory tract regions (i.e., ET, TB and PU) and not for localized areas such as the respiratory versus olfactory epithelium. The choice of the experimental data and description of the model are provided in Appendix G.

The default model used in the RfC methodology estimates regional deposition. "Dose" may be accurately described by deposition alone if the particles exert their primary action on the surface contacted (Dahl et al., 1991a), but since the RfC is defined as a dose-response estimate for chronic exposures, a more appropriate dose metric for particle exposures may be to take into account clearance of the deposited dose and thereby calculate the retained dose and the dose rate to extrapulmonary tissues. Incorporation of clearance kinetics into the dosimetric adjustments awaits development of data enabling comparable modeling of clearance across species. Often the physicochemical properties or mechanisms of action of the inhaled toxicant (particle or gas) can be used to gauge the relative importance of the various factors controlling inhaled dose. For example, the model of Yu and Yoon (1990) for

diesel exhaust incorporates clearance components such as transport of deposited particles to the lymphatic system. A model that described the retained dose for diesel particles was necessary because the toxicity is related to particle overload.

3.2.2 Gas Categorization Scheme Directs Default Gas Modeling

Numerous model structures have been used to describe toxicant uptake in the respiratory tract. The type of model often reflects the physicochemical characteristics of the gases to which they are applied. For example, the model of Miller et al. (1985) for the respiratory tract uptake of ozone (highly reactive and moderately water soluble) is a detailed, distributed parameter model. Key elements incorporated into this convective-diffusion-chemical reaction model include (1) anatomic dimensions of the airspace and tissue thickness (2) dispersion in the airspace, (3) reactivity in the liquid lining (mucus or surfactant) covering the cells of the lower respiratory tract, and (4) lateral mass transport resistance from the airspace to the blood (Overton et al., 1987). Models for highly reactive and highly soluble gases (e.g., formaldehyde, hydrogen fluoride) have emphasized the requirement to account for scrubbing of the gas from the airstream by the upper respiratory tract (Aharonson et al., 1974; Morgan and Frank, 1977; Morris and Smith, 1982; Hanna et al., 1989; Cassanova et al., 1991). Such models are not applicable to a nonreactive gas such as styrene, however.

The chemical-specific or class-specific nature of these models has been dictated by the physicochemical characteristics of the subject gases, and therefore, any single model is not applicable to the broad range of gases that the RfC methodology must address. Dahl (1990) categorized gases as stable, reactive, or metabolizable based on their thermodynamic and kinetic properties. Various concepts of "dose" can be related to these properties and the mechanism of action (e.g., macromolecular bound fraction as dose for reactive gases versus inhaled dose for stable asphyxiants). A gas categorization scheme was constructed based on physicochemical characteristics as determinants of gas uptake as shown in Figure 3-9. A similar scheme has been developed by the International Commission on Radiological Protection (1993). The definition of reactivity includes both the propensity for dissociation as well as the ability to serve as a substrate for metabolism in the respiratory tract. The scheme does not apply to inert gases that exert their effect by reversible "physical" interactions of

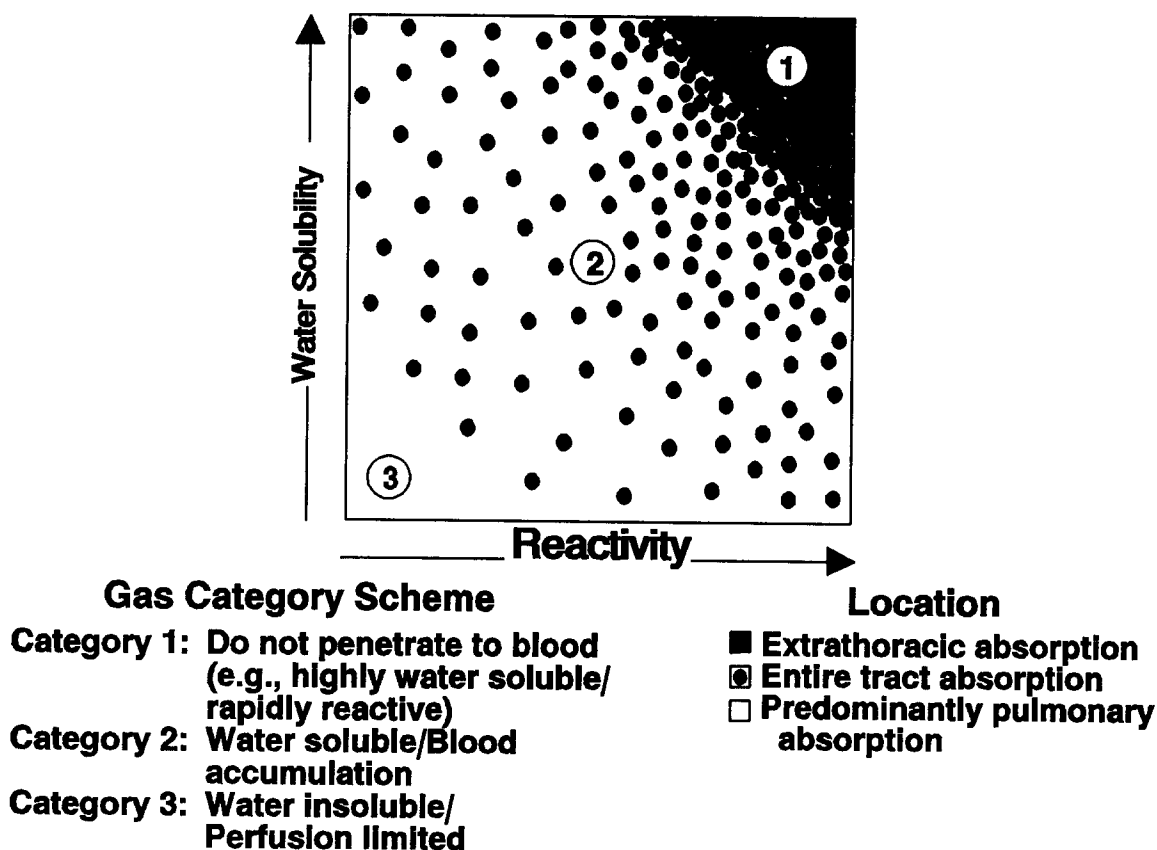

Figure 3-9. Gas categorization scheme based on water solubility and reactivity as major determinants of gas uptake. Reactivity is defined to include both the propensity for dissociation as well as the ability to serve as a substrate for metabolism in the respiratory tract. Definitive characteristic of each category and anticipated location (region) for respiratory tract uptake are shown.

gas molecules with biomolecules (e.g., "displacement" of oxygen by carbon dioxide). Consideration of this mechanism was discussed in Section 2.1.2.3.

The dominant determinants are used to construct a conceptual framework that directs development of the default dosimetry model structures discussed in Appendices I and J. These model structures are reduced further by simplifying assumptions to forms requiring a minimal number of parameters in order to derive the default adjustments used in Chapter 4 for each category that are commensurate with the amount of data typically available for RfC chemicals.

The two categories of gases with the greatest potential for respiratory effects are (1) gases that are highly water soluble and/or rapidly irreversibly reactive and (2) water soluble gases which may also be rapidly reversibly reactive or moderately to slowly irreversibly metabolized in respiratory tract tissue. The objective of the default modeling approach is to describe the effective dose to the three major regions of the respiratory tract (ET, TB, PU) by addressing the absorption or "scrubbing" of a relatively water soluble and/or reactive gas from the inspired airstream as it travels from the ET to PU region. That is, the dose to the peripheral regions (TB and PU) is affected by the dose to the region immediately proximal. The appropriateness of assessing proximal to distal dose representative of the scrubbing (uptake) pattern is supported by the proximal to distal progression pattern of respiratory tract toxicity with increasing concentration that is observed with many chemicals (Jarabek, 1994). At low concentrations of highly water soluble and/or irreversibly reactive gases, observed effects are largely isolated to the ET region. At higher concentrations, more severe effects occur in the ET region and toxicity is also observed to progress to the peripheral regions. The severity of toxicity also progresses distally with increased exposure concentrations. As for the default particle deposition model described in Appendix G, the default gas models do not describe respiratory tract uptake in detail to the level of local airflow distribution (e.g., respiratory versus olfactory epithelium), but they do adequately describe the scrubbing of the chemical from the inhaled airstream on a regional scale.

The defining characteristic for Category 1 gases is that they are so highly water soluble and/or rapidly irreversibly reactive in the surface-liquid/tissue of the respiratory tract that they do not develop a significant backpressure (i.e., reversal in the concentration gradient at the gas-liquid interface) from the surface-liquid tissue phase during exhalation. Category 1 gases are also distinguished by the property that the gas does not significantly accumulate in the blood which would reduce the concentration driving force and, hence, reduce the absorption rate. The default model structure is based on these characteristics. Examples of gases classified as Category 1 are hydrogen fluoride, chlorine, formaldehyde, and the volatile organic acids and esters.

Gases in Category 2 are moderately water soluble and rapidly reversibly reactive or moderately to slowly irreversibly metabolized in respiratory tract tissue. Ozone, sulfur

dioxide, xylene, propanol, and isoamyl alcohol are examples of Category 2 gases. The boundaries between categories are not definitive. Some compounds may appear to be defined by either Category 1 or Category 2 because water solubility and reactivity are a continuum. Thus, although sulfur dioxide is reversibly reactive, which would categorize it as a Category 2 gas, it is also highly soluble such as to be a Category 1 gas. Similarly, ozone is highly reactive yet only moderately water soluble. More explicit delineation of categories will be made upon review of the empirical data and the predictability of the model gases that may appear to fit more than one category.

Because they are not as reactive in the respiratory tract tissue as Category 1 gases, gases in Category 2 have the potential for significant accumulation in the blood and thus have a higher potential for both respiratory and remote toxicity. Thus, the model structure used to describe uptake of these gases is a hybrid of that for Category 1 and Category 3. The PBPK model component of the structure is necessary to evaluate the steady-state blood concentration which allows calculation of both absorption flux on inhalation and the desorption flux during exhalation. The derivation of the model structures and their reduction to forms with a minimal number of parameters are described in detail in Appendix I.

Gases in Category 3 are relatively water insoluble and unreactive in the ET and TB surface liquid and tissue and thus result in relatively small dose to these regions. The uptake of Category 3 gases is predominantly in the pulmonary region and is perfusion limited. Styrene is an example of a Category 3 gas. The site of toxicity of these gases is generally at sites remote to the respiratory tract and a compartmental approach can be used to describe distribution to various systemic tissues. Thus, the default model for Category 3 gases is similar in structure to the PBPK model used by Ramsey and Andersen (1984) to describe styrene distribution. The model structure and the derivation of the default dosimetric adjustment based on this model are described in detail in Appendix J.

3.2.3 Summary Considerations for Judging Model Structures

Although a comprehensive description of the exposure-dose-response continuum is desired for accurate extrapolation from experimental conditions and dose-response assessment, often the data base is inadequate. The preceding chapter discussion illustrates that data on the mechanistic determinants of chemical disposition, toxicant-target interactions, and tissue

responses vary in degree of availability for chemicals and species. Depending on the relative importance of these various determinants, models with less detail may be used as a default to adequately describe differences in dosimetry for the purposes of interspecies extrapolation often required for the chemicals at which the RfC methodology is directed. The default dosimetry models incorporated in the methodology represent structures that are commensurate with the available data for both chemical-specific (e.g., reactivity and solubility) and species-specific (e.g., respiratory tract airway dimensions, surface areas, ventilation rates, deposition data, distribution of cell types, metabolic capacities) parameters.

An understanding of the basis for model structures also allow development of a framework for the evaluation of whether an alternative model structure is considered optimal relative to the default. For example, an alternate model structure might be considered more optimal than the default for extrapolation when default assumptions or parameters are replaced by more detailed, biologically-motivated descriptions or actual data, respectively. For example, a model could be considered more optimal if it incorporates more chemical or species-specific information or if it accounts for more mechanistic determinants. These considerations are summarized in Table 3-6.

TABLE 3-6. HIERARCHY OF MODEL STRUCTURES FOR DOSIMETRY AND INTERSPECIES EXTRAPOLATION

Optimal model structure

Structure describes all significant mechanistic determinants of chemical disposition, toxicant-target interaction, and tissue response

Uses chemical-specific and species-specific parameters

Dose metric described at level of detail commensurate to toxicity data

Default model structure

Limited or default description of mechanistic determinants of chemical disposition, toxicant-target interaction, and tissue response

Uses categorical or default values for chemical and species parameters

Dose metric at generic level of detail

The sensitivity of the model to these differences in structure may be gauged by their relative importance in describing the response function for a given chemical. A model which incorporates many parameters may not be any better at describing ("fitting") limited response data than a simpler model. In these instances, the principle of parsimony might dictate the use of the simpler model.

Woodruff et al. (1992) used Monte Carlo analyses to assess the impact that structure and parameterization of PBPK models has on output predictions and variability. Nonphysiologically based (NPB) models of three or two compartments were compared with PBPK models that either used five compartments (PBPK5) to describe the body (well-perfused, poorly-perfused, fat, bone marrow, and liver tissue compartments) or that "lumped" the body into three (fat, bone marrow, and central) compartments (PBPK3). Comparisons were run for different data sets from inhalation to benzene. The two main influences on variability of model output predictions were (1) the quantity and type of data used to calibrate the model and (2) the number of parameters in the model. While some differences existed between the models' average predictions when calibrated to the same experimental data, these differences were smaller than the differences between the predictions made by the same model fitted to different data sets. An excessive number of parameters was shown to lead to overparameterization and cause large variability in the output. The similarities in the average predictions of the NPB and PBPK models supported the use of NPB models in some cases. The NPB models have fewer parameters and are potentially easier to fit. The PBPK models did show greater reliability for extrapolation but NPB models provided reliable results with less effort needed in fitting data when the objective was to interpolate from the current data.

Issues addressed in the review by Woodruff et al. (1992) and others (Hattis et al., 1989; Farrar et al., 1989; Portier and Kaplan, 1989; Bois et al., 1990) regarding evaluation of the uncertainty in input parameters and the variability of predictions due to alternate structures and data sets, should be considered when evaluating different available model structures for replacing the default adjustments.

4. QUANTITATIVE PROCEDURES

This chapter presents the quantitative procedures for dose-response¹ assessment for noncancer toxicity. Once key studies have been identified in the available data base for a chemical and evaluated for adequacy and limitations in terms of experimental design and analysis, dose-response assessment for noncancer toxicity involves the designation of the critical effects for each individual study, dosimetric adjustment of the associated exposure concentrations to human equivalent concentrations (HECs), and an analysis of the overall data array of these effects for that which is most representative of the threshold region. It is this no-observed-adverse-effect level (NOAEL) for the critical effect, together with uncertainty factors (UFs), that is used for the derivation of the inhalation reference concentration (RfC). An RfC has a numerical value, and hence, a quantitative nature. As discussed throughout this document, numerous theories, assumptions, and empirical data provide the quantitative framework for these RfC calculations. To account for inherent uncertainties in the chemical-specific data base and essential qualitative judgments, levels of confidence are assigned, enhancing the interpretation of a numerical RfC.

This chapter begins in Section 4.1 with a discussion of the minimum data base criteria to develop an RfC and of how to evaluate the available data to determine that a sufficient number of appropriate endpoints were addressed to ascertain the potential for noncancer toxicity. Guidance on how to designate effect levels (i.e., assign exposure levels as NOAELs or lowest-observed-adverse-effect levels [LOAELs]) is provided in Section 4.2. The remainder of the chapter is dedicated to the dosimetric adjustments used to extrapolate the experimental data to an HEC, according to whether the observed toxicity is in the respiratory tract or is extrapulmonary (sites remote to the portal of entry) and according to the type of inhaled toxicant. Conversion of experimental units to the units of the RfC (mg/m^3) and

¹Although the strict definitions of "dose", "response", and "effect" are recognized and discussed explicitly in Section 1.2., the conventions of the NAS paradigm will be used in this document, with the RfC being synonymous with a "dose-response" assessment. Thus, in the broader sense, the term "dose" may encompass administered dose (i.e., exposure concentration), delivered dose, or target tissue dose. Likewise, "response" in the qualitative sense, is an indication of an adverse influence regardless of whether the data were measured as quantal, count, continuous, or ordered categorical. The reader is referred to Section 1.2 for a detailed discussion of the general principles of dose-response and assessment for noncancer toxicity.

adjustment for discontinuous experimental exposure duration are described in Sections 4.3.2 and 4.3.3, respectively. The dosimetric adjustments for particles are discussed in Section 4.3.5 and for gases in Section 4.3.6. Duration and dosimetric adjustment of human data is discussed in Section 4.3.7. Once the effect levels are converted to HECs, the choice of the critical effect and principal study is made according to the guidance in Section 4.3.8. The operational derivation of an RfC is provided and the choice of UFs and assignment of confidence levels discussed in Sections 4.3.8.1 and 4.3.8.2, respectively.

4.1 MINIMUM DATA BASE CRITERIA

Noncancer toxicity is defined as health effects other than cancer and gene mutations that are due to the effects of environmental agents on the structure or function of various organ systems. Therefore, by definition, a data base for derivation of a dose-response estimate for noncancer toxicity should ensure that both appropriate and adequate numbers of endpoints have been evaluated.

As shown in Table 4-1, the minimum laboratory animal toxicologic data base requirement for derivation of an RfC with low confidence is a well-conducted subchronic inhalation bioassay that evaluated a comprehensive array of endpoints, including an adequate evaluation of portal-of-entry (respiratory tract) effects, and established an unequivocal NOAEL and LOAEL. For a higher confidence RfC, chronic inhalation bioassay data, two-generation reproductive studies, and developmental studies in two different mammalian species are usually required. Considerations related to evaluating the comprehensiveness of the available data according to these criteria follow in Section 4.1.1. Oral data may be used, according to the criteria and guidance provided in Section 4.1.2, when inhalation data are not available. Typically, the level of confidence in a given RfC will be higher if it is derived from human data and supported by laboratory animal data. A more detailed discussion of how to assign confidence levels is provided in Section 4.3.9.2.

4.1.1 Evaluation of Comprehensiveness

Data bases vary considerably in their completeness. The rationale supporting the minimum data base requirements for derivation of an RfC, as outlined above, is that

TABLE 4-1. MINIMUM DATA BASE FOR BOTH HIGH AND LOW CONFIDENCE IN THE INHALATION REFERENCE CONCENTRATION (RfC)

Mammalian Data Base ^a	Confidence	Comments
1. A. Two inhalation bioassays ^b in different species B. One two-generation reproductive study C. Two developmental toxicity studies in different species	High	Minimum data base for high confidence
2. 1A and 1B, as above	Medium to high	
3. Two of three studies, as above in 1A and 1B; one or two developmental toxicity studies	Medium to high	
4. Two of three studies, as above in 1A and 1B	Medium	
5. One of three studies, as above in 1A and 1B; one or two developmental toxicity studies	Medium to low	
6. One inhalation bioassay ^c	Low	Minimum data base for estimation of an RfC

^aComposed of studies published in refereed journals, reports that adhered to good laboratory practice and have undergone final QA/QC, or studies rated by the Office of Pesticide Programs as "core-minimum". It is understood that adequate toxicity data in humans can form the basis of an RfC and yield high confidence in the RfC without this data base. Pharmacokinetic data that indicate insignificant distribution occurs remote to the respiratory tract may decrease requirements for reproductive and developmental data.

^bChronic data.

^cChronic data preferred but subchronic acceptable.

well-defined and well-conducted subchronic toxicity studies are generally considered to be reliable predictors of many forms of chronic toxicity, with the notable exceptions of carcinogenic, teratogenic, and reproductive effects. Testing is required in two different species, in the absence of a relevant laboratory animal model, in order to address potential species sensitivity. The additional specific requirement for adequate respiratory tract evaluation arises from the increased potential for the portal-of-entry tissue to interact intimately with chemicals. The observation that approximately 70% of the RfCs derived to date (October, 1994) have been based on respiratory tract endpoints is consistent with this increased potential.

It should be recognized, however, that for some substances, results of other studies may suggest the possibility of effects not detected in the subchronic studies. Current toxicity testing strategies are hierarchical sequences of tests designed to develop a profile of a chemical's toxicity (Environ Corporation, 1985). Initial testing tiers consist of relatively rapid, inexpensive tests designed to identify acute toxicity. This information is not directly useful in predicting chronic adverse effects in humans, but can be used to guide decisions as to type and extent of other testing required, such as subchronic, chronic, or reproductive bioassays. The toxicity "profiles" or information required as a minimum data base also are somewhat structured according to this hierarchy. The magnitude of data insufficiency varies on a case-by-case basis and should be defined by the nature of the plausible or possible pathogenesis processes (i.e., defined according to the possible mechanism[s] of action for the observed effect[s]). For example, the U.S. Food and Drug Administration (1982) suggests that if a chemical tested in a subchronic study is found to cause focal hyperplasia, metaplasia, proliferative lesions or necrosis, then a carcinogenicity study in two rodent species is warranted. Likewise, if reproductive effects are found, then teratology testing also should be conducted. If acute or subchronic data demonstrate reproductive organ toxicity or neurotoxic effects, standard 2-generation reproductive assays, developmental testing, and a neurotoxicity battery may be required for appropriate characterization. Pharmacokinetic data that indicate insignificant distribution to sites remote from the respiratory tract at exposure concentrations under consideration for derivation of an RfC can mitigate the requirements for reproductive and developmental data, except when these endpoints are suggested as potential targets by other inhalation data. Route-to-route extrapolation of oral data, according to the criteria provided in the next section, may provide a qualitative gauge by which to judge the relative sensitivity of these endpoints to those under consideration for the respiratory tract or other target tissues.

The quantitative relationships between these various endpoints and how to evaluate the entire data array for determination of the principal studies on which to base the derivation of the RfC are discussed in Section 4.3.8.

4.1.2 Route-to-Route Extrapolation

When the data base for a given chemical is not adequate via inhalation, route-to-route extrapolation is often practiced by some risk assessors using empirically derived factors that are not necessarily applicable to the case at hand. For most route-to-route extrapolations, the lack of data, lack of ability to interpret data, and underutilization of existing data due to insufficient models and statistics reduce or eliminate the validity of these extrapolations (Gerrity and Henry, 1990).

Data from other routes of exposure may be useful to derivation of an RfC only when respiratory tract effects and/or "first-pass" effects (a pharmacologic phenomenon) can be ruled out. First-pass effects refer to the metabolism that can take place in the portal-of-entry tissue, prior to entry into the systemic circulation. For example, after oral administration, many chemicals are delivered to the liver via the portal vein from the gastrointestinal (GI) tract before they enter into the systemic circulation.

The respiratory tract can also exhibit a first-pass effect after inhalation due to its various cell types and metabolic enzyme systems. This first-pass action can alter the disposition of the parent and metabolites, thereby modulating the dose to remote or systemic target tissues in a route-dependent fashion. Therefore, unless this first-pass effect and dosimetry are adequately understood, there can be substantial error introduced in route-to-route extrapolation that does not account for these parameters. In the absence of data to determine dosimetry via inhalation, when a chemical is thought to be susceptible to first-pass effects (e.g., metabolized), or where a potential for portal-of-entry effects is indicated but not well characterized (e.g., respiratory toxicity after acute exposures or skin irritation after dermal administration), then route-to-route extrapolation for derivation of an RfC is not appropriate. For a more detailed discussion of important parameters to consider, refer to Gerrity and Henry (1990), the National Research Council (1986, 1987), and Pepelko and Withey (1985).

Oral toxicity data are the most common data available as alternatives to inhalation data. Oral data should not be used for route-to-route extrapolation in the following instances:

- (1) when groups of chemicals are expected to have different toxicity by the two routes; for example, metals, irritants, and sensitizers;
- (2) when a first-pass effect by the respiratory tract is expected;

- (3) when a first-pass effect by the liver is expected;
- (4) when a respiratory tract effect is established, but dosimetry comparison cannot be clearly established between the two routes;
- (5) when the respiratory tract was not adequately studied in the oral studies; and
- (6) when short-term inhalation studies, dermal irritation, in vitro studies, or characteristics of the chemical indicate potential for portal-of-entry effects at the respiratory tract, but studies themselves are not adequate for an RfC development.

Dose-response data from other routes of exposure, such as intravenous, intraperitoneal, subcutaneous, dermal, and intramuscular routes also may be available. Intravenous data may provide reliable information for certain chemicals (e.g., metabolizable or stable but not rapidly reactive) on blood levels but such information would have to be supplemented by knowledge of the quantitative relationship between inhalation exposure concentration and blood levels in order to be useful. The other routes generally have a much more limited usefulness in route-to-route extrapolation because the pharmacokinetics are, in general, poorly characterized.

The ability to perform quantitative route-to-route extrapolation is critically dependent upon the amount and type of data available. Regardless of the toxic endpoint being considered, a minimum of information is required to construct plausible dosimetry for the routes of interest. This information includes both the nature of the toxic effect and a description of the relationship between exposure and the toxic effect. Illustration for this rationale is provided by Figures 4-1 and 4-2.

Figure 4-1 shows physiologically based pharmacokinetic (PBPK) model simulations of the concentrations required to result in a comparable "administered dose" (mg/kg/BW) after gavage with different vehicles (oil or water), oral exposure via drinking water, or inhalation for different durations (6 or 24 h). For gavage and drinking water studies, dose was defined as the total amount of chloroform entering the gastrointestinal tract. Administered dose for inhalation studies was defined as the product of inhaled air concentration (mg/L) and the alveolar ventilation rate (L/h). Absorption efficiency was assumed to be 100%. For a

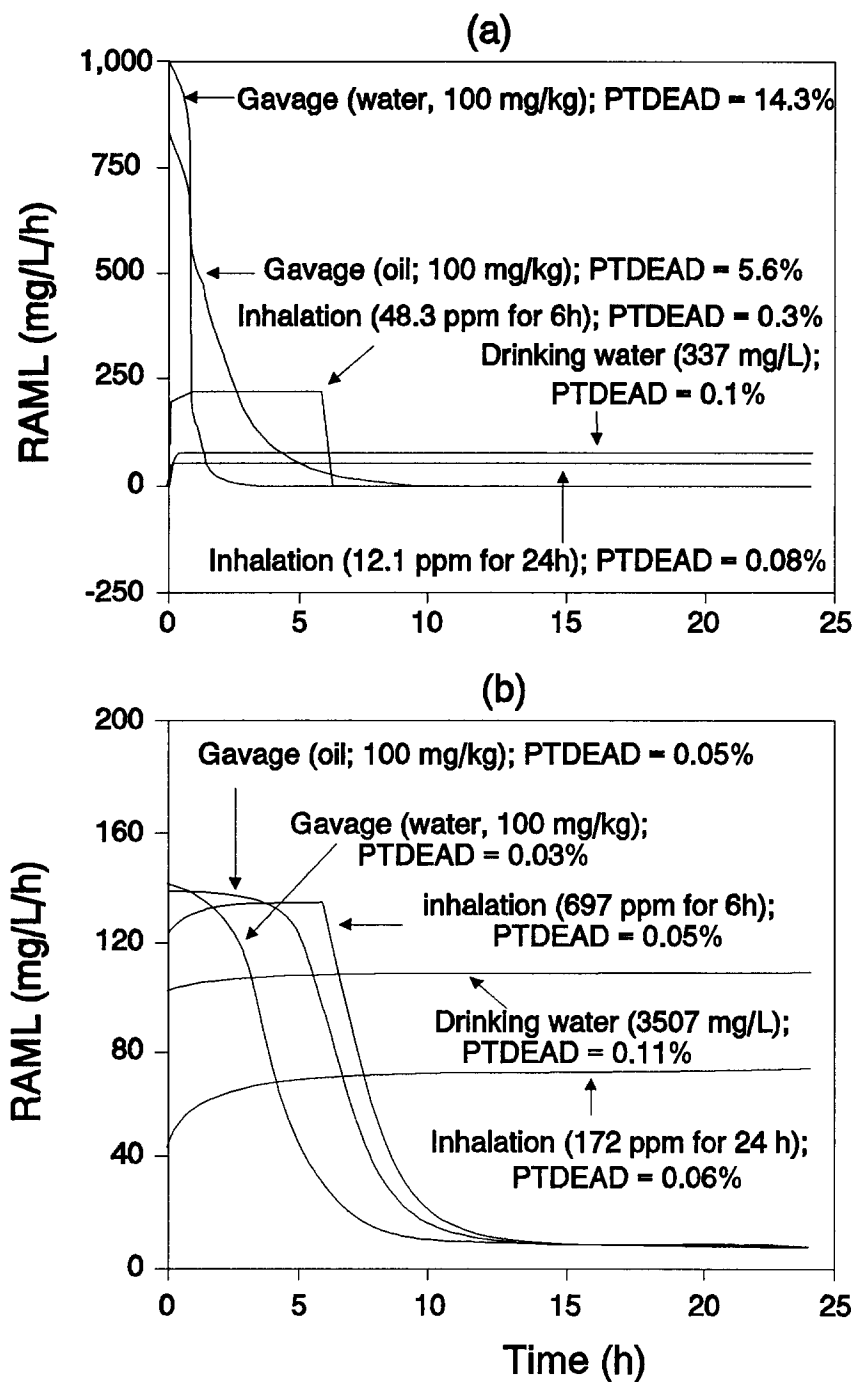

Figure 4-1. Multiple route comparisons for (a) mice and (b) humans administered chloroform at a dose of 100 mg/kg body weight. Actual concentrations of chloroform in air or in drinking water used to deliver a total body burden comparable to a gavage dose of 100 mg/kg and the percentage of liver cells killed (PTDEAD) as a result of the exposures are labeled for each simulation. Model simulations are of the rates of metabolism in the liver (RAML, mg/L of liver/h) for 24 h.

Source: Corley and Reitz (1990).

Conc./Dose	Inhalation	Ingestion
<p>Low</p>  <p>High</p>	<p>Slight pulmonary irritation</p> <p>Slight renal tubular damage</p> <p>Chronic bronchitis (COPD)</p> <p>Progressing renal damage</p> <p>Changes in Ca and Vit D metabolism</p> <p>Lung cancer</p> <p>Anaemia</p> <p>Uremia</p> <p>Osteomalacia and osteoporosis</p>	<p>Slight renal tubular damage</p> <p>Decrease in intestinal Ca absorption</p> <p>Progressing renal damage</p> <p>Changes in Ca and Vit D metabolism</p> <p>Intestinal mucosa damage</p> <p>Anaemia</p> <p>Uremia</p> <p>Osteomalacia and osteoporosis</p>

Figure 4-2. Differential effects of inhaled and ingested cadmium with increasing inhaled and ingested doses.

Source: Oberdörster (1990).

detailed discussion of the PBPK model structure and parameter values, refer to Corley and Reitz (1990). The figure is used here to highlight the differences in administered dose by various routes required to achieve the same internal dose in a target tissue, in this case, the liver. The model predicts the percentage of hepatocytes killed in the liver due to the metabolism of parent compound. Note the different profiles of metabolism via the different routes in Figure 4-1. The degree of cytotoxicity predicted by the model simulations was in the order of gavage (water) > gavage (corn oil) >> inhalation (6 h) > drinking water > inhalation (24 h). This figure also illustrates the interspecies differences in the processes involved. For example, to produce a total body burden of chemical comparable to that

achieved by an exposure dose of 100 mg/kg/day of chloroform, the concentration of the 24-h inhalation exposure was increased from 12 ppm in the mouse to 172 ppm for the humans.

Figure 4-2 shows the qualitative relationships of differential effects after either inhalation or ingestion of cadmium (Cd) (Oberdörster, 1990). It is apparent that the exposure route influences the target organ effects. Respiratory effects have only been observed after inhalation exposures and GI tract effects only after oral exposure. Portal-of-entry effects are obviously of importance. In contrast, remote effects such as those on the kidney, bone, and the hematopoietic system are observed after exposure by either route. However, the portal of entry also modulates the dose rate to the remote tissues. Using a simplified steady-state PBPK model of a few basic transfer kinetics (e.g., 90% of inhaled soluble Cd is absorbed; 5% of ingested) for soluble Cd compounds (e.g., cadmium oxide, cadmium chloride), Oberdörster (1990) estimated that $1 \mu\text{g}/\text{m}^3$ of inhaled (24-h) Cd was equivalent to $21.5 \mu\text{g}$ (daily ingested) and $1,000 \mu\text{g}$ (daily ingested) for renal and respiratory effects, respectively. The great disparity in potency by different routes for Cd emphasizes the point that dosimetry should be established for each relevant route when either contact site or remote toxicity is a concern.

Therefore, the actual impact of exposure by different routes can only be estimated by taking account of factors that influence absorption at the portal of entry, such as (1) physicochemical characteristics of the chemical (e.g., dissociation state, molecular weight, partition coefficient, reactivity, solubility), (2) exposure factors (e.g., concentration, duration, regimen), and (3) physiologic parameters (e.g., barrier capacity as related to variability in species, blood flow, cell types and morphology, metabolism, pH, specialized absorption sites, storage in cells), and those parameters that influence dose remote to the portal of entry, including metabolism, clearance, tissue binding, tissue blood flows, tissue:blood partition coefficients, and tissue volumes.

Evaluation of the adequacy of the available data to address the factors outlined above is the basis for the decision tree shown in Figure 4-3 (Gerrity and Henry, 1990). As discussed above, route-to-route extrapolation for quantitative dose-response assessment should only be considered when concern for contact-site (portal-of-entry) toxicity has been ruled out (Option 2 of Figure 4-3 is sufficient only for hazard identification). Although the fact that

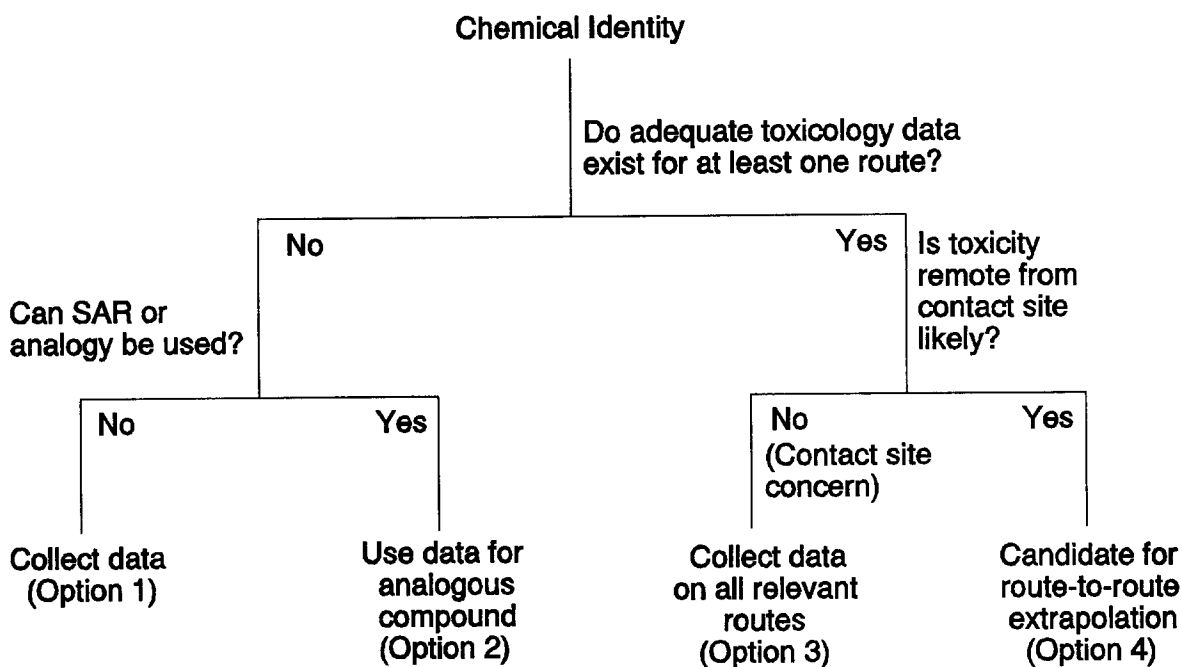

Figure 4-3. Decision tree for route-to-route extrapolation (see text below for a discussion of the options listed). SAR = structure activity relationship.

Source: Gerrity and Henry (1990).

the effect of a chemical is observed in the portal of entry does not necessarily preclude route-to-route extrapolation, the requirements for quantitative data via each route (Option 3 of Figure 4-3) in order to perform such an extrapolation usually obviate the reason (i.e., lack of data) for which it was being considered in the first place.

If respiratory tract toxicity can be ruled out and remote site toxicity is of interest, then route-to-route extrapolation becomes a possibility (Option 4 of Figure 4-3). Methods for route-to-route extrapolation range in accuracy and therefore, inherent uncertainty. The simplest approach is to use default absorption values for each exposure route appropriate to the chemical class in question. Such values have only been developed for a limited class of volatile organic chemicals. Because this approach entails an increased uncertainty compared to those that use pharmacokinetic data and PBPK modeling, use of default absorption values is considered inadequate for quantitative dose-response assessment.

Direct measurement of absorption efficiency for the routes of interest is an improvement on the use of default values, but the approach still ignores many of the potentially important factors mentioned above, invoking additional uncertainty that would have to be accounted for when calculating a dose-response estimate. Measurement of bioavailability by the use of a validated internal marker provides greater certainty. Comparative excretion data when the associated metabolic pathways are equivalent by each route and regimen of interest or comparative systemic toxicity data when such data indicate equivalent effects by each route and regimen of interest may also provide useful information. However, the associated uncertainty would have to be accounted for in the estimate derived using an extrapolation based on such data.

The preferred method for performing route-to-route extrapolation involves the development of a PBPK model that describes the disposition (deposition, absorption, distribution, metabolism, and elimination) of the chemical for the routes of interest (Gerrity and Henry, 1990). Such models account for fundamental physiologic and biochemical parameters and processes such as blood flows, ventilatory parameters, metabolic capacities, and renal clearance, tailored by the physicochemical (e.g., blood:air and tissue:blood partitions) and biochemical properties (e.g., binding, depletion of co-factors) of the chemical in question.

The use of a PBPK model is predicated on the assumption that an effective (target-tissue) dose achieved by one route in a particular species is expected to be equally effective when achieved by another exposure route or in some other species. A key determination is the choice of the dose surrogate for the toxic effect. The more accurately the exposure-dose-response continuum is characterized, and therefore the correlation of the chosen dose surrogate with toxic effect, the more accurate this approach will be with respect to use in quantitative extrapolation. For example, a measure of target-tissue dose for a chemical with pharmacologic activity could be the tissue concentration divided by some measure of the receptor-binding constant for that chemical. The behavior of a substance administered by a different exposure route can be determined by adding equations that describe the nature of the new input function. Similarly, because known physiologic parameters are used, different species (e.g., humans versus laboratory animal species) can be modeled by replacing the appropriate constants. It should be emphasized that PBPK models must be used in

conjunction with toxicity and mechanistic studies in order to relate the effective dose associated with an effect for the test species and conditions to other scenarios. The use of an existing model structure, essentially a template, can greatly reduce the effort required for model development of analogous chemicals.

4.1.3 Not-Verifiable Status

When the available data do not meet the minimum data base requirements as discussed above or when the existing data can not be synthesized into a compelling toxicity profile without great uncertainty (see Section 4.3.8), the data base on a given chemical is designated as "not-verifiable" and no RfC estimate is calculated. This status would require reanalysis when new data become available.

4.2 DESIGNATION OF EFFECT LEVELS

The designation of effect levels, or the association of adversity² with exposure concentrations, is one of the most difficult procedures of any dose-response analysis for noncancer toxicity. The critical effect for an individual study is often described as either the adverse effect that first appears in the dose scale as dose is increased, or as a known precursor to the first adverse effect. The premise of this designation is the underlying threshold phenomenon and it assumes that if this critical effect is prevented then all observed adverse effects at subsequent concentrations are prevented. In the simplest terms, a NOAEL and a LOAEL are determined for the specified adverse effect from the exposure levels of a given individual study for each of the various species tested. The NOAEL is the highest level tested at which the specified adverse effect (i.e., a biologically and statistically defined adverse effect) is not produced and is, thus, by definition, a subthreshold level (Klaassen, 1986). The NOAEL/LOAEL is a function of the exposure levels used in the experimental

²Here adverse effects are considered to be functional impairments or pathological lesions that may affect the performance of the whole organism or that reduce an organism's ability to cope with an additional challenge (Federal Register, 1980). One of the major problems encountered with this concept is the reporting of "observed effect levels" as contrasted to "observed adverse effect levels." The terms "adverse" and "not adverse" are at times satisfactorily defined, but because more subtle responses continue to be identified due to increasingly sophisticated testing protocols, scientific judgment is needed regarding the exact definition of adversity.

design, or is a function of designating a specified health effect measure (e.g., 10% incidence of a lesion) as the outcome of interest in the case of some alternative approaches presented in Appendix A³, and therefore, does not necessarily reflect the "true" biological threshold.

Table 4-2 presents the four types of effect levels that may be applicable when evaluating an individual study. Historically, the distinction between adverse effects and nonadverse effects has been and remains problematic. For example, although disease is a dynamic process (injury, adaptation, or healing), a pathologist records a morphologic change at a single point in time and these "freeze-frame" data are used to determine the probable cause and pathogenesis (past) and probable progression or outcome (future). Designation of an effect level (i.e., the designation of adversity) requires interpretation of the data based on an ability to deduce the preceding events that have led to the observed change and to predict the outcome or progression. The relationship between structural alterations to altered function is not always simple, however.

Determining whether altered morphology is an adaptive response or truly an expression of toxicity (functional impairment) can be extremely difficult and even controversial (Burger et al., 1989; Ruben and Rousseaux, 1991). In some cases, structural alteration can occur, but normal function can continue in target tissues with functional reserve such as the lung, liver, and kidney. Not all tissues demonstrate this high reserve. The central nervous system can compensate to only a limited degree and where the damage occurs is vitally important for the function of the system. Therefore, "focal" damage may be adverse in some but not all target tissues. Also, the lack of observed functional change may be due to failure to detect subtle or unknown functional changes rather than to their absence.

A similar morphologic alteration may have both functional and physiologic significance, but often it is difficult to differentiate toxicity from physiologic response by morphologic means alone. Not all functional abnormalities manifest themselves morphologically. Temporal-spatial patterns are particularly challenging when evaluating toxicologic pathology. Problems concerning time include reversibility, adaptation versus toxicity, progression versus

³There are alternative approaches under development (presented and discussed in Appendix A) aimed at deriving estimates of exposures that are analogous in intent to the establishment of a NOAEL. The NOAEL/LOAEL approach outlined is not intended to discourage alternative or more sophisticated dose-response procedures when sufficient data are available, but rather to present key issues necessarily involved (e.g., dosimetric adjustment and data array analysis) in any approach for the assessment of noncancer toxicity.

TABLE 4-2. FOUR TYPES OF EFFECT LEVELS^a (RANKED IN ORDER OF INCREASING SEVERITY OF TOXIC EFFECT) CONSIDERED IN DERIVING INHALATION REFERENCE CONCENTRATIONS FOR NONCANCER TOXICITY

NOEL:	No-Observed-Effect Level. That exposure level at which there are no statistically and biologically significant increases in frequency or severity of effects between the exposed population and its appropriate control.
NOAEL:	No-Observed-Adverse-Effect Level. That exposure level at which there are no statistically and biologically significant increases in frequency or severity of adverse effects ^b between the exposed population and its appropriate control. Effects are produced at this level, but they are not considered to be adverse.
LOAEL:	Lowest-Observed-Adverse-Effect Level. The lowest exposure level in a study or group of studies that produces statistically and biologically significant increases in frequency or severity of adverse effects between the exposed population and its appropriate control.
FEL:	Frank Effect Level ^c . That exposure level that produces frankly apparent and unmistakable adverse effects, such as irreversible functional impairment or mortality, at a statistically and biologically significant increase in frequency or severity between an exposed population and its appropriate control.

^aNote that these levels represent points on a continuum and are not discrete.

^bAdverse effects are defined as any effects resulting in functional impairment and/or pathological lesions that may affect the performance of the whole organism, or that reduce an organism's ability to cope with an additional challenge.

^cFrank effects are defined as overt or gross adverse effects (e.g., severe convulsions, lethality, etc.).

regression, and peracute lethal toxicity. Problems concerning space are limited to missing the lesion completely or missing a relevant area because of sampling method. For example, histologic examination of the nasal cavity should select four tissue sections, not one, to achieve a thorough examination (Young, 1981). Further, due to the proximal to distal inspiratory airstream, some examination of the upper respiratory tract is indicated when respiratory toxicity from an inhaled irritant is evident in the lower respiratory tract.

Due to the structural-functional and temporal-spatial problems discussed above, an approach that integrates pathological studies (ultrastructural, histochemical, cellular, and molecular) with functional methods is recommended (Ruben and Rousseaux, 1991). Morgan (1991) has provided guidance on the identification and interpretation of URT lesions in toxicologic studies. A systematic but flexible approach to evaluation of lesions in the URT is

recommended, one that considers selection of section level in context with the physicochemical characteristics of the inhaled gas (e.g., water solubility and reactivity), the role of factors that may account for lesion distribution (e.g., dosimetry and tissue susceptibility), and development of a pathogenesis profile or a chronological order of events (e.g., degenerative, adaptive, and adaptive/regenerative changes versus time). The nasal diagrams proposed by Mery et al. (in press) offer an approach to recording data and mapping lesions that aids this type of interpretation strategy. This approach is also likely the best to compile the data and precludes the restraint to interpretation and mathematical modeling presented by data scored categorically for severity (e.g., + = mild, ++ = moderate; and +++ = severe) and/or without sufficient section detail with respect to lesion location (Jarabek, 1994).

In the early stages of respiratory disease, there is considerable uncertainty concerning how to differentiate between acute reversible effects, which are the immediate consequence of an exposure episode, and potential progression to chronic, nonreversible respiratory pathology. The boundary between adaptive and toxic responses also remains controversial for some respiratory tract lesions (Burger et al., 1989). These are important issues both in terms of evaluation of respiratory tract effects per se, as well as for decisions concerning the critical effect in inhalation studies. Inhalation-specific issues such as evaluation of pulmonary function, sensory irritation, and allergic sensitization data are discussed in Section 2.2.

Designation of effect levels usually contains an element of scientific judgment in addition to objective criteria. Considerable experience and precedent for such decisions have accrued over the last several years in the process of developing oral reference doses, RfCs, and other health-related benchmark estimates. Table 4-3 presents guidance as to how general effects would usually be designated as different (adverse) effect levels. In general, effects that may be considered marginal are designated as adverse only to the extent that they are consistent with other structural and functional data suggesting the same toxicity. For example, altered liver enzymes (statistically out of normal range) would only be considered adverse in context with altered structure (pathology) and liver weight changes.

**TABLE 4-3. EFFECT LEVELS CONSIDERED IN
DERIVING INHALATION REFERENCE CONCENTRATIONS
IN RELATIONSHIP TO EMPIRICAL SEVERITY RATING VALUES
(Ranks are from lowest to highest severity.)^a**

Effect or No-Effect Level	Rank	General Effect
NOEL	0	No observed effects.
NOAEL	1	Enzyme induction or other biochemical change, consistent with possible mechanism of action, with no pathologic changes and no change in organ weights.
NOAEL	2	Enzyme induction and subcellular proliferation or other changes in organelles, consistent with possible mechanism of action, but no other apparent effects.
NOAEL	3	Hyperplasia, hypertrophy, or atrophy, but no change in organ weights.
NOAEL/LOAEL	4	Hyperplasia, hypertrophy, or atrophy, with changes in organ weights.
LOAEL	5	Reversible cellular changes including cloudy swelling, hydropic change, or fatty changes.
(LO)AEL ^b	6	Degenerative or necrotic tissue changes with no apparent decrement in organ function.
(LO)AEL/FEL	7	Reversible slight changes in organ function.
FEL	8	Pathological changes with definite organ dysfunction that are unlikely to be fully reversible.
FEL	9	Pronounced pathologic changes with severe organ dysfunction with long-term sequelae.
FEL	10	Death or pronounced life shortening.

^aAdapted from DeRosa et al. (1985) and Hartung (1986).

^bThe parentheses around the "LO" in the acronym "LOAEL" refer to the fact that any study may have a series of doses that evoke toxic effects of rank 5 through 7. All such doses are referred to as adverse effect levels (AELS). The lowest AEL is the (LO)AEL.

4.3 CALCULATION OF HUMAN EQUIVALENT CONCENTRATIONS

A key element of extrapolation of laboratory animal inhalation data to humans is estimation of the "dose" (i.e., agent mass deposited per unit surface area or tissue volume) delivered to specific target sites in the respiratory tract or made available to uptake and metabolic processes for systemic distribution considered with mechanistic determinants of toxicant-target interactions and tissue responses (Martonen and Miller, 1986; Andersen et al., 1991). To this end, PBPK and other mathematical dosimetry models have evolved into particularly useful tools for predicting disposition differences for risk assessment (Miller et al., 1987b). Their use is predicated on the assumption that an effective (target-tissue) dose in a particular species is expected to be equally toxic when achieved in some other species. However, it is likely that species differences in sensitivity occur due to such species-specific factors as host defense, repair processes, and genetics, so that the use of a 10-fold UF to account for intraspecies variability, despite application of dosimetric adjustments, requires additional research.

This section outlines the methods for calculating HEC estimates by using adjustment factors that have resulted from similar modeling efforts of species-specific dosimetry differences. The factors are used to adjust the observed exposure effect levels (i.e., NOAELs, LOAELs, etc.) in laboratory animals to estimate a concentration that would be an equivalent exposure to humans (i.e., $\text{NOAEL}_{[\text{HEC}]}$ s, $\text{LOAEL}_{[\text{HEC}]}$ s, etc). These HECs then are the basis for comparison and choice of the critical effect and study.

As discussed in Section 3.2, the equations presented in this chapter are default adjustments based on dosimetry models that incorporate only the major determinants of particle or gas disposition. The use of models that may incorporate a more comprehensive description of the exposure-dose-response continuum is considered the optimal approach in each case. It should also be noted that because PBPK models allow for explicit handling of intermittent exposure regimens (e.g., model can simulate 6 h/day, 5 days/7 days exposure and predict resultant internal dose), the duration adjustment discussed in Section 4.3.2 is obviated by the use of these models.

Figure 4-4 is a flowchart for the default calculation of HECs and provides an outline for the contents of this section. Conversion of units from ppm to mg/m^3 is required before dosimetric adjustments can be applied. This calculation is discussed in Section 4.3.1. The

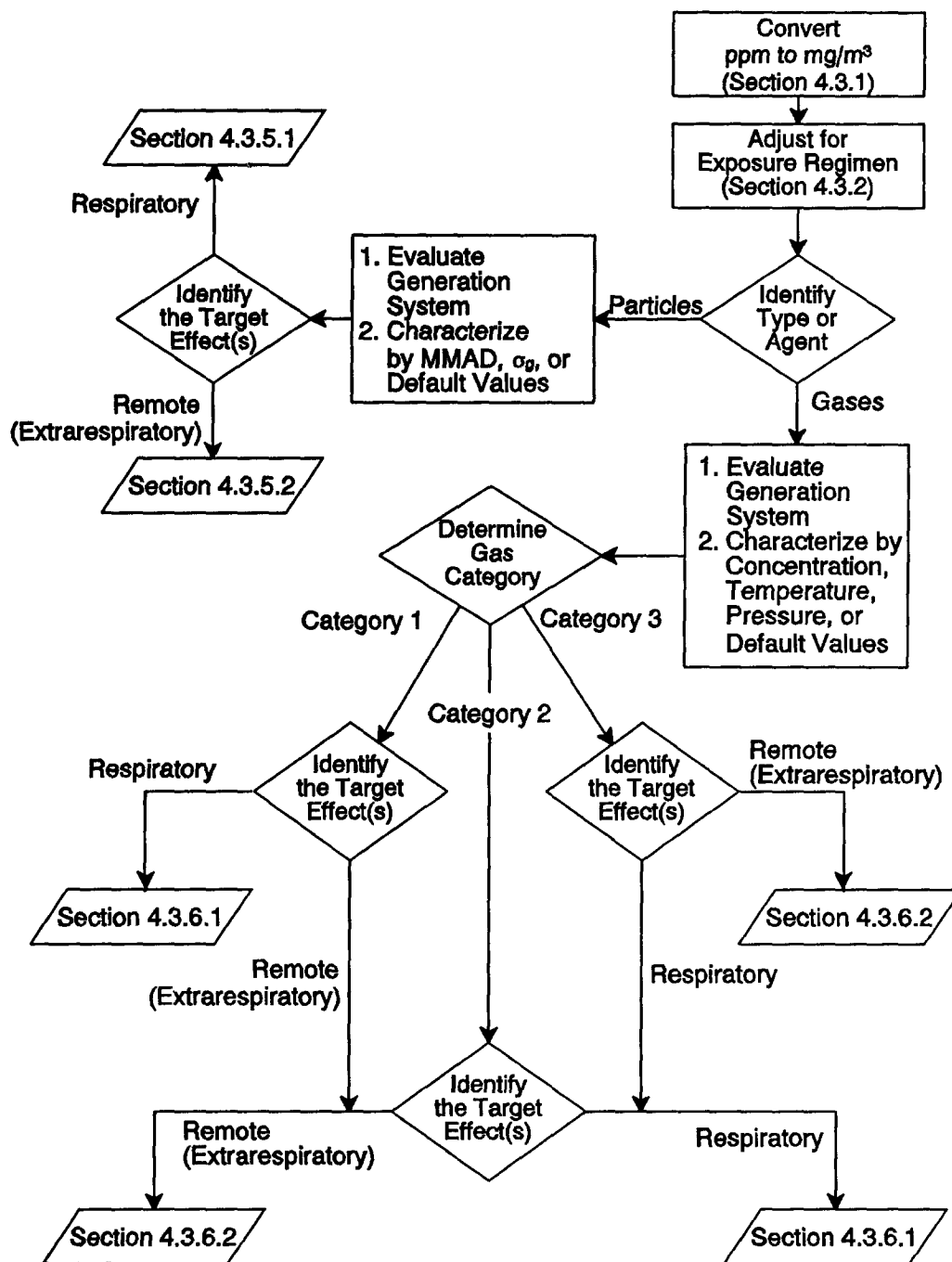

Figure 4-4. Flowchart for calculation of human equivalent concentrations.

next step in calculating a HEC is to convert the exposure regimen of the experiment in question to that of the human exposure scenario; that is, a continuous (24-h/day) lifetime (70-year) exposure. The third step of the approach is to apply the dosimetric adjustments appropriate for the type of toxicant to be assessed (particle or gas, and if a gas, what category) and the effect to be assessed (respiratory tract or extrarrespiratory toxicity) resulting from an inhalation exposure. The default dosimetric adjustments to derive HECs for respiratory tract effects and extrarrespiratory effects of particles are provided in Section 4.3.5. For gases, the determination of the appropriate gas category according to the scheme provided in Section 3.2.2 is required to determine which dosimetric adjustment to apply to calculate an HEC. Because the boundaries between the categories are not definitive (see discussion in Section 3.2.2 and Appendix I), but instead were made to allow derivation of default model structures, identification of the target effect(s) is used to further define the gas category. Thus, remote (extrarrespiratory) effects of Category 1 gases and respiratory effects of Category 3 gases are treated according to the default dosimetric adjustments for each of these respective effects of Category 2 gases (Section 4.3.5 and 4.3.6). The default dosimetric adjustments to derive HEC values for respiratory effects of Category 1 gases are provided in Section 4.3.5. The default dosimetric adjustment to derive HEC values for extrarrespiratory effects of Category 3 gases is provided in Section 4.3.6.

Although the presentation in this section divides the dosimetry calculations into those applied to extrapolate respiratory tract effects versus extrarrespiratory effects, it should be recognized that there is no strict compartmentalization of effects for a chemical. A given inhaled chemical could cause both respiratory tract and extrarrespiratory effects. Therefore, the decision on which of the equations to use in this chapter is governed by the endpoint of interest in concert with the properties of the chemical to be assessed.

4.3.1 Conversion to Standard Units

In the rare event that investigations using particulate exposures would report the concentration in ppm, a mass-density relationship should be used to convert the exposure concentration to mg/m^3 . Inhalation toxicity studies on gases typically employ exposure levels expressed as mg/m^3 or ppm. Exposure levels for gases, including the NOAEL selected for RfC derivation, should be expressed in standard units of mg/m^3 . For exposure levels

expressed as ppm, the Ideal Gas Law should be used to derive the corresponding mg/m³ level:

$$\frac{\text{mg}}{\text{m}^3} = \text{ppm} \times \frac{\text{g-mole}}{22.4\text{L}} \times \frac{\text{MW}}{\text{g-mole}} \times \frac{273^\circ}{\text{T}} \times \frac{\text{P}}{760 \text{ mm Hg}} \times \frac{10^3\text{L}}{\text{m}^3} \times \frac{10^3\text{mg}}{\text{g}}, \quad (4-1a)$$

where:

ppm = concentration expressed on a volumetric basis $\frac{\text{L}}{10^6\text{L}}$,

MW = molecular weight in grams,

22.4 L = the volume occupied by 1 g-mol of any compound in the gaseous state at 0 °C and 760 mm Hg,

T = actual temperature in degrees Kelvin, and

P = actual pressure in mm Hg.

At 25 °C and 760 mm Hg, 1 g-mole of a perfect gas or vapor occupies 24.45 L. Therefore, under these conditions, the conversion becomes

$$\text{mg/m}^3 = \frac{\text{ppm} \times \text{MW}}{24.45}. \quad (4-1b)$$

4.3.2 Temporal Relationships of Toxicity and Duration Adjustment

Many inhalation toxicity studies using laboratory animals use discontinuous exposure regimens. Often exposures are for 6 to 8 h/day and 5 days/week. Inhalation reference concentrations are constructed to reflect a benchmark level for continuous exposure.

By extension, the RfC also is assumed to be protective for discontinuous exposures at the same air concentration. A normalization to some given exposure (e.g., 24 h/day for a lifetime of 70 years) is needed to adjust for the wide variety of experimental exposures to permit comparisons between studies. As discussed earlier, the RfC proposed herein is to reflect lifetime continuous exposure, making this scenario the objective of normalization.

Attention should be paid to the degree this scenario deviates from the experimental, and to

the physicochemical (solubility and reactivity) parameters of the inhaled agent and species-dependent factors (e.g., distribution volumes and metabolic pathways) that might temper this conversion.

To calculate duration-adjusted exposure levels in mg/m^3 for experimental animals, the equation is

$$\text{NOAEL}^*_{[\text{ADJ}]} (\text{mg}/\text{m}^3) = E (\text{mg}/\text{m}^3) \times D (\text{h}/24 \text{ h}) \times W (\text{days}/7 \text{ days}), \quad (4-2)$$

where:

$\text{NOAEL}^*_{[\text{ADJ}]}$ = the NOAEL or analogous effect level obtained with an alternate approach as described in Appendix A, adjusted for duration of experimental regimen;

E = experimental exposure level;

D = number of hours exposed/24 h; and

W = number of days of exposure/7 days.

- NOTE:**
1. *This same duration adjustment is applied to LOAELs.*
 2. *This duration adjustment is not applied when PBPK models are used (see Section 4.3.3).*
 3. *Duration adjustment for human data is discussed in Section 4.3.6.*

The rationale for this linear prorated adjustment is that the resultant human exposure concentration should be the concentration (C) \times time (T) equivalent of the experimental animal exposure level. This adjustment is weakly founded because steady-state conditions may not be reached in laboratory animals for some chemicals and intermittent regimens and because the influence of dose-rate is different for different toxicity mechanisms (e.g., an effect mediated by peak blood concentration versus integrated tissue dose). Thus, depending on the mechanism of action, such duration adjustment may be inappropriate. Toxic effects of gases such as irritation, narcosis or asphyxia may be much more dependent on concentration than duration. An attempt should always be made to take into account the mechanisms of toxic action as related to the temporal parameters of duration and frequency, although C \times T is rarely investigated after subchronic or chronic durations. Unless more information is available on a case-by-case basis, this default is used.

As the effect in question increases in its severity, the validity of this equation becomes more tenuous. The toxicity of an exposure is dependent upon the character of the "concentration-time" ($C \times T$) curve, which may be described by a hyperbola whose arms converge asymptotically toward the axes of the coordinates (Bliss, 1940). Bliss and James (1966) have shown that such curves can be extrapolated with minimal error when the time points in the experiment are located on the segment of the curve asymptotically approaching the axes of the coordinates (i.e., high concentration acute exposures or low concentration chronic exposures). The exposure duration should ideally embrace the time span in which the rate of onset of specific toxic effects sharply change, reflecting the degree of arc in the curve of the ($C \times T$) relationship.

Fiserova-Bergerova et al. (1980), using a compartmentalized model based on first-order kinetics, demonstrated that duration of exposure to a gas can have profound effects on the fractions of uptake exhaled or metabolized. Concentrations in tissues reflected the concentration fluctuations in exposure, but the fluctuation in tissues was greater during exposure to low solubility gases than to lipid soluble vapors (blood:air partition coefficients of 0.5 and 10.0, respectively), due to the faster equilibration of partial pressures of the low solubility gases. Fluctuations between tissue and exposure concentrations were diminished if the substances were metabolized. Because a toxic effect is usually related to tissue concentration, consideration should be given to these duration and solubility effects. Extrapolation on the basis of $C \times T$ should be attempted only if a steady-state was attained. Likewise, linear extrapolation from one concentration exposure to another is scientifically supportable only if all processes involved in the uptake and elimination of the inhaled agent are first order. Differences are caused primarily by concentration-dependent metabolic clearance.

4.3.3 Use of Pharmacokinetic and Pharmacodynamic Data

Pharmacokinetic and pharmacodynamic data (described in Section 1.2) can be used in a range of applications, from providing adjustments to external exposures based on correlations of exposure to effect, through gathering insight on various important mechanistic insights and calculation of kinetic parameters, to developing a comprehensive exposure-dose-response description that incorporates major determinants of toxicant disposition, toxicant-target

interaction and tissue response. These data can also be used to ascertain what laboratory animal species is most appropriate, based on similarity of major mechanistic determinants, for extrapolation to humans.

Empirical equations such as correlation equations (e.g., that relate the extent of external exposure with the amount of internal biologic markers) can be used to describe kinetic processes by a simple mathematical expression. These data, as described in Section 4.1.2, may be useful as a qualitative index of uptake for a given route, but they provide no insight into the other parameters controlling disposition of a toxicant (distribution, metabolism, excretion) over time and therefore their use is rather restricted.

Experimental data that track the concentrations of various kinetic parameters during and following exposures can be used to determine various measures of the intensity of tissue exposure. The parameters that are proportional to the relevant measure of tissue exposure are referred to as tissue dose metrics (Andersen, 1987). These metrics include estimates of time integrals of tissue exposure to a parent toxicant or its metabolite(s) (e.g., area under the blood [AUBC] or tissue curve [AUTC]), concentrations of these materials in tissues, or receptor occupancy caused by the presence in tissues. This information provides little insight into the mechanistic determinants or the biological effect of the parent or its metabolite(s). The choice of which metric to use as an appropriate measure should be based on some knowledge of the mechanism by which the toxic effects are induced.

This mechanistic knowledge does not necessarily have to be exhaustive, but can rather be related to certain general aspects of the nature and causes of a particular toxic interaction. For example, is the effect related to chemical reactivity or to occupancy of cellular receptor molecules? Is the effect associated with the parent or with a metabolite? If it is a metabolite, does the metabolite have a sufficiently long half-time in the body to circulate freely throughout the body or is it so reactive that it likely produces its damage locally? Are the effects themselves reversible cytotoxic phenomena or irreversible changes? Is there sufficient time for the target tissue to recover from the damage within the exposure frequency interval?

If the critical damaging toxicant-target interaction is caused by direct chemical reaction in which the toxicant reacts with and consumes cellular constituents, the degree of damage should be related to the time integral of tissue exposure to the reactive chemical (e.g., AUTC). This definition would likely need to incorporate quantitative information on the

synthesis and normal catabolism of the macromolecules involved to describe chronic exposures accurately. If the toxicant interacts with tissue by noncovalent binding to cellular receptor molecules, the response of the cell is dependent on the occupancy of the receptor and occupancy is determined by the binding constant for the chemical and the free concentration of the toxicant in the cell.

The use of categorization schemes based on the physicochemical properties or mechanisms of action of the inhaled toxicant have been proposed and different concepts of "dose" related to these (National Research Council, 1986; Andersen, 1987; O'Flaherty, 1989; Dahl, 1990). Considerations such as these are described in Section 3.2. and went into the development of the default dosimetry adjustments provided in the following Sections 4.3.5 through 4.3.7. Details on the development of the dosimetry models are provided in Appendices G, I and J. The default adjustments are determined categorically for particles versus gases, and within gases, for those more reactive and soluble than nonreactive and insoluble. Reactivity is defined to include both the propensity for dissociation as well as the ability to serve as a substrate for metabolism in the respiratory tract. Because these are default dosimetry adjustments, the use of models that may incorporate a more comprehensive description of the exposure-dose-response continuum is considered the optimal approach for extrapolation to HECs when such a model is judged to provide a more accurate description. This judgment may be based on whether the structure of the alternative model is superior to that of the default, (e.g., incorporates known mechanistic determinants) or if it empirically results in a better correlation between "dose" and "effect". The reader is referred to Section 3.2 for a discussion of modeling comparative dosimetry and to Section 3.2.3 for summary considerations regarding judging model structures.

Use of more comprehensive models obviate the need for the duration adjustment described above in Section 4.3.2 because such models employ parameters that describe time-dependent determinants of toxicant disposition such as metabolic clearance, distribution volumes and elimination constants. These models can therefore be used to simulate both the experimental exposure regimen as well as the exposure scenario for the human. PBPK and linear pharmacokinetic models have both been used to evaluate and to adjust for different work place exposure durations (Droz, 1985; Andersen et al., 1987b; Saltzman, 1988). For example, in order to extrapolate laboratory animal data using a PBPK model, the laboratory

animal regimen (e.g., 6 h/day, 5 days/week) is simulated and the resultant appropriate dose metric (e.g., AUTC) calculated. This is done assuming steady-state conditions for chronic studies if it is likely that these conditions were met for 90% of the time (see Section 4.3.5), or the entire exposure can be simulated with the model. The model is then used with the human parameters to ascertain the exposure concentration that results in an equivalent dose metric under the human exposure scenario (e.g., 24 h/day). This exposure concentration back-extrapolated from the equivalent dose metric is the HEC.

4.3.4 Default Dosimetric Adjustment and Physiological Parameters

As described in Sections 3.2 and 4.3.3., the dosimetric adjustment factors described in the following sections are default approaches to be used when more sophisticated or chemical-specific models are not available. The HEC is calculated with the default dosimetric adjustment factor as:

$$\text{NOAEL}^*_{[\text{HEC}]} (\text{mg}/\text{m}^3) = \text{NOAEL}^*_{[\text{ADJ}]} (\text{mg}/\text{m}^3) \times \text{DAF}_r \quad (4-3)$$

where:

$\text{NOAEL}^*_{[\text{HEC}]}$ is the NOAEL or analogous effect level obtained with an alternate approach as described in Appendix A, dosimetrically adjusted to an HEC,

$\text{NOAEL}^*_{[\text{ADJ}]}$ is defined in Equation 4-2, and

DAF_r is a dosimetric adjustment factor for respiratory tract region, r (ET, TB, PU, TH, or TOTAL), either the regional deposited dose ratio (RDDR_r) for particles or the regional gas dose ratio (RGDR_r) for gases.

The DAF represents a multiplicative factor used to adjust an observed exposure concentration in a particular laboratory species to an exposure concentration for humans that would be associated with the same delivered dose. The calculation of the RDDR_r for particles and the RGDR_r for gases is described in section 4.3.5 and 4.3.6, respectively.

Depending on whether the observed toxicity is in the respiratory tract or at remote (extrarespiratory) sites, the DAF_r is used in conjunction with default normalizing factors for the physiological parameter of interest. Because insoluble particles deposit and clear along the surface of the respiratory tract, dose per unit surface area is a commonly used

normalizing factor for respiratory effects due to particulate deposition; body weight is often used to normalize dose to remote target tissues. In some cases, it may be appropriate to normalize by regional volumes or target organ weights. For gases, use of mass flux (mass per surface area-time) is considered a reasonably accurate predictor of the peak localized concentration driving the absorption gradient for respiratory tract effects. For example, if the observed toxicity is in the TB region, the dose deposited in that region for each species is normalized to the TB surface area for each species.

Default values of surface area (SA) for the various respiratory tract regions of five commonly tested animal species are provided in Table 4-4. Selection of the values was based on a meeting of experts in laboratory animal and human morphometric measurements convened in August 1991 (Jarabek, 1991). At that time, a thorough review of the literature had been conducted and the group was presented with summary tables of surface area measurements; animal information (as available) including strain, body weight, sex and age; tissue preparation, and morphometric measurement technique. Based on discussion among the expert group members, values were identified as most representative of a species and designated as the default. These values do not always correspond exactly to the published value that is cited in Table 4-4, most generally due to rounding.

TABLE 4-4. DEFAULT SURFACE AREA VALUES FOR RESPIRATORY EFFECTS^a

	ET (cm ²)	Source	TB (cm ²)	Source	PU (m ²)	Source
Human	200.0	Guilmette et al. (1989)	3,200.0	Mercer et al. (1994a)	54.0	Mercer et al. (1994b)
Mouse	3.0	Gross et al. (1982)	3.5	Mercer et al. (1994a)	0.05	Geelhaar and Weibel (1971), Mercer et al. (1994b)
Hamster	14.0 ^b		20.0	Yu and Xu (1987)	0.3	Lechner (1978)
Rat	15.0 ^c	Gross et al. (1982)	22.5	Mercer et al. (1994a)	0.34	Mercer et al. (1994b)
Guinea Pig	30.0	Schreider and Hutchens (1980)	200.0	Schreider and Hutchens (1980)	0.9	Tenney and Remmers (1963)
Rabbit	30.0	Kliment (1973)	300.0	Kliment (1973)	5.9	Gehr et al. (1981)

^aET = Extrathoracic.

TB = Tracheobronchial.

PU = Pulmonary.

^bNo measurements of hamster ET surface area were found in the literature. This value is estimated based on similarity of the other regional surface areas to the rat.

^cAdditional unpublished measurements of the surface area beyond the ethmoid turbinates are included.

Body weight is the recommended normalizing factor for remote (extrarespiratory) effects. The default body weight values for the same five animal species are provided in Table 4-5. The body weight for the human is the weight used by the International Commission on Radiological Protection (Snyder et al., 1975) for the Reference Man. The values in Table 4-5 are taken from U.S. Environmental Protection Agency (1988a) and provide recommended values for body weights when evaluating subchronic or chronic studies in a variety of strains for each species. Often information on the strain used in a particular study can be obtained from the principal investigator in the rare event that it is not provided in the journal articles. If different strains are used than those in Table 4-5 and the body weight is reported, choose the strain with the most comparable body weight. Documents on recommended values for use in risk assessment (U.S. Environmental Protection Agency, 1988a) and for use in physiologically based models (U.S. Environmental Protection Agency, 1988b) are useful sources of default values for parameters such as ventilation rates and body weights for use in these equations when these values are not supplied in individual investigations. Available allometric equations (Adolph, 1949; Weibel, 1972; U.S. Environmental Protection Agency, 1988a), relating body size to the parameters of interest such as ventilatory rates and lung surface areas also may be appropriate. It must be emphasized that the use of default or derived values must be consistent with the dosimetric modeling parameters and approaches used in adjusting concentrations to human equivalent values, such as the parameters used to calculate the $RDDR_T$ and $RGDR_T$.

The default ventilation values for minute volume [$\dot{V}_E = \text{tidal volume } (V_T) \times \text{breathing frequency } (f)$] are calculated using the allometric scaling equations provided in U.S. Environmental Protection Agency (1988a). The general form for the equation is:

$$\log (\dot{V}_E) = b_0 + b_1 \log(BW) \quad (4-4)$$

where log refers to the natural logarithm, \dot{V}_E is in L/min and body weight (BW) is in kg. The species specific parameters (b_0 and b_1) are listed in Table 4-6. At the present time, the default body weight for the human is defined to be 70 kg, and the \dot{V}_E is defined to be (13.8 L/min) 20 m³/day.

TABLE 4-5. BODY WEIGHT (kg) DEFAULT VALUES—RATS

Strain	Sex	Subchronic	Chronic
Fisher 344	F	0.124	0.229
Fisher 344	M	0.180	0.380
Sprague-Dawley	F	0.204	0.338
Sprague-Dawley	M	0.267	0.523
Long-Evans	F	0.179	0.344
Long-Evans	M	0.248	0.472
Osborne-Mendel	F	0.201	0.389
Osborne-Mendel	M	0.263	0.514
Wistar	F	0.156	0.297
Wistar	M	0.217	0.462

BODY WEIGHT (kg) DEFAULT VALUES—MICE

Strain	Sex	Subchronic	Chronic
B6C3F1	F	0.0246	0.0353
B6C3F1	M	0.0316	0.0373
BAF1	F	0.0204	0.0222
BAF1	M	0.0223	0.0261

BODY WEIGHT (kg) DEFAULT VALUES—HAMSTER

Strain	Sex	Subchronic	Chronic
Syrian	F	0.095	0.145
Syrian	M	0.097	0.134
Chinese and Djungarian	F	0.025	0.038
Chinese and Djungarian	M	0.03	0.041

BODY WEIGHT (kg) DEFAULT VALUES—GUINEA PIGS

Strain	Sex	Subchronic	Chronic
Not specified	F	0.39	0.86
Not specified	M	0.48	0.89

BODY WEIGHT (kg) DEFAULT VALUES—RABBITS

Strain	Sex	Subchronic	Chronic
New Zealand	F	3.10	3.93
New Zealand	M	2.86	3.76

Source: U.S. Environmental Protection Agency (1988a).

TABLE 4-6. INTERCEPT (b_0) AND COEFFICIENT (b_1) VALUES USED IN ALGORITHM (Equation 4-4) TO CALCULATE DEFAULT MINUTE VOLUMES BASED ON BODY WEIGHT

	b_0	b_1
Rat	-0.578	0.821
Mouse	0.326	1.050
Hamster	-1.054	0.902
Guinea pig	-1.191	0.516
Rabbit	-0.783	0.831

Source: U.S. Environmental Protection Agency (1988a).

4.3.5 Dosimetric Adjustments for Particle Exposures

Inhalation toxicologists have advanced their ability to measure the deposition of particles in the various regions of the respiratory tract across species. Initially the data were primarily total deposition values for polydisperse and sometimes unstable aerosols, but data now exist for insoluble monodisperse aerosols of different sizes under different breathing conditions (U.S. Environmental Protection Agency, 1982b). Data are available for many experimental species of interest on the regional deposition of aerodynamic particle size ranges and on the necessary physiologic parameters (e.g., ventilation parameters and regional surface areas) incorporated in dose adjustments (Overton et al., 1987; Miller et al., 1987b; Miller et al., 1988; Raabe et al., 1988; Patra et al., 1986; Patra, 1986). Deposition data are usually reported as the deposition fraction for each respiratory tract region of the species of interest. Deposition fraction is the ratio of the number or mass of particles deposited in the respiratory tract to the number or mass of particles inhaled. Deposition data also may be expressed as efficiencies, that is the amount deposited in a particular region normalized for the amount entering that region.

Knowledge also has been gained in the technology and methods for generating and characterizing aerosols. State-of-the-art inhalation toxicology studies characterize the particulate exposure by the particle diameter (e.g., aerodynamic equivalent diameter [d_{ae}], aerodynamic resistance diameter [d_{ar}], mass median aerodynamic diameter [MMAD]), and the geometric standard deviation (σ_g). Appendix H provides information on converting

reported particle units to those used in the calculation of the dosimetric adjustment factor and guidance on default values.

These advances in quantitation of species-specific regional respiratory tract deposition and characterization of physiologic parameters have been used in the development of an empirical model that accounts for dosimetry differences using deposition data typical for aerodynamic particles. This application is an adaptation (Miller et al., 1983b; Graham et al., 1985) and an extension (Miller et al., 1988; Jarabek et al., 1989, 1990) of previous work. A series of empirical equations were fit to experimental measurements of regional particle deposition in various laboratory species and humans as described in Appendix G. These equations are used to estimate fractional deposition and, in conjunction with normalizing factors such as body weight or surface area, are used to adjust for dosimetric differences between species in the calculation of an HEC. The approach is limited at this time to relatively insoluble and nonhygroscopic particles.

The derivation of the $\text{NOAEL}_{[\text{HEC}]}$ for insoluble, approximately spherical particles is described as

$$\text{NOAEL}_{[\text{HEC}]}^* (\text{mg}/\text{m}^3) = \text{NOAEL}_{[\text{ADJ}]}^* (\text{mg}/\text{m}^3) \times \text{RDDR}_r, \quad (4-5)$$

where:

$\text{NOAEL}_{[\text{HEC}]}^*$ = the NOAEL or analogous effect level obtained with an alternate approach as described in Appendix A, dosimetrically adjusted to an HEC;

$\text{NOAEL}_{[\text{ADJ}]}^*$ = is defined in Equation 4-2; and

RDDR_r = a multiplicative factor used to adjust an observed inhalation particulate exposure concentration of an animal (A) to the predicted inhalation particulate exposure concentration for a human (H) that would be associated with the same dose delivered to the r^{th} region or target tissue:

$$\text{RDDR}_r = \frac{(\text{RDD}_r/\text{Normalizing Factor})_A}{(\text{RDD}_r/\text{Normalizing Factor})_H}$$

The *r regions* and potential target tissues identified by this calculation are the three respiratory tract regions (extrathoracic [ET], tracheobronchial [TB], or pulmonary [PU]).

Definitions of the three regions are provided in Chapter 3 of this document. The $RDDR_r$ can also be calculated for the thoracic (TH) region (TB plus PU regions) or the total (TOT) respiratory tract (all three respiratory tract regions). Total deposition (deposition summed for all three regions) is assumed to be available for transport to other organs and is used to calculate the RDDR for extrarespiratory (ER) effects.

It is frequently desirable to use a *normalizing factor* when comparing doses across species. Because insoluble particles deposit and clear along the surface of the respiratory tract, dose per unit surface area is a commonly used normalizing factor for particulate deposition in the respiratory tract. In some cases, it might be desirable to normalize by regional volumes, organ weight, or body weight. It might also be appropriate to examine the dose ratio with no normalizing factor. The appropriate normalizing factor to use may also be judged according to the guidance provided in Section 4.3.3 on the use of pharmacokinetic and pharmacodynamic data, with heed to the cautionary notes provided in the following sections.

Regional deposited dose (RDD_r) is estimated as

$$RDD_r = 10^{-6} \times C_i \times \dot{V}_E \times F_r \quad (4-6)$$

where:

RDD_r = dose deposited in region r, mg/min,

C_i = concentration, mg/m³,

\dot{V}_E = minute volume, mL/min,

F_r = fractional deposition in region r.

The $RDDR_r$ may be expressed as a series of four ratios:

$$RDDR_r = \frac{(10^{-6} \times C_i)_A}{(10^{-6} \times C_i)_H} \times \frac{(\text{Normalizing Factor})_H}{(\text{Normalizing Factor})_A} \times \frac{(\dot{V}_E)_A}{(\dot{V}_E)_H} \times \frac{(F_r)_A}{(F_r)_H} \quad (4-7)$$

For the purposes of calculating the $RDDR_r$, the exposure concentration for the laboratory animal (A) and human (H) are assumed to be the same because it is assumed that the observed effect in the laboratory animal is relevant to human health risk. Therefore, the $RDDR_r$ provides a factor to adjust for the difference in dose delivered to the target tissue

under the same exposure scenario. The first term in Equation 4-7, therefore, equals one and will not be discussed further.

The second term in Equation 4-7 is the ratio of the normalizing factors for the human and laboratory animal of interest. For effects in any or all of the three regions of the respiratory tract, surface area (see Table 4-4) is the recommended normalizing factor. To evaluate extrapulmonary effects, body weight (see Table 4-5) is the recommended normalizing factor. The third term of Equation 4-7 is the ratio of minute volumes (see Equation 4-4).

The final term in the $RDDR_r$ equation is the ratio of regional fractional deposition in laboratory animals and humans. By means of nonlinear regression, empirical equations have been fit using experimentally measured regional deposition in both laboratory animals and humans. Details on the estimation procedures are provided in Appendix G. These equations provide predictions for approximately spherical, nonhygroscopic, insoluble particles in the aerodynamic size range (particle diameter $> 0.5 \mu\text{m}$). Deposition fractions should not be calculated using these equations if the particles deviate enough from spherical that they are not reasonably described by an aerodynamic diameter (e.g., fibers) or if the particles are smaller than $0.5 \mu\text{m}$ (see Appendix H for a discussion of particle-related issues). Predicted deposition of hygroscopic particles may be approximated by these equations using the equilibrium particle size, if known. Other techniques to estimate fractional deposition are required for particles falling outside the assumptions of this empirical model.

The $RDDR_r$ is most easily calculated using the software available as a supplement to this document. For near monodisperse particles ($\sigma_g \leq 1.3$), deposition fractions may be calculated as described in Appendix G and the $RDDR_r$ calculated by hand. For polydisperse particles ($\sigma_g > 1.3$), however, deposition fractions are calculated by integrating the product of the monodisperse deposition probabilities and the log-normal distribution. This calculation must be done by computer. The software to perform the $RDDR_r$ calculation is written in C and will run on any DOS-based personal computer. A math coprocessor chip is not required. Figures 4-5 to 4-8 illustrate the four screens of the program. The first three figures show how the program display screens will look during data entry, while Figure 4-8 reproduces the $RDDR_r$ s that would be calculated using these input data.

```

This program calculates the regional deposited dose ratio
for rodent/human for a particle characterized by a given mass median
aerodynamic diameter (MMAD) and geometric variance (sigma g).
v.2.2

Enter the MMAD in microns (.5 - 30): 2.3

Enter the sigma g(>=1.0): 1.8
Computationally sigma g < 1.3 will be considered monodisperse

Press Esc key to quit, Enter to continue, any other key to repeat.

```

Figure 4-5. Display Screen 1 of the computer program that calculates regional deposited dose ratios.

```

Human information:

default Body weight      = 70.00 (Kg)
default Minute Volume (VE) = 13.00 (Liters)
default ET surface area  = 200.00 (cm2)
default TB surface area  = 3200.00 (cm2)
default PU surface area  = 54.00 (m2)

Press Esc key to quit, Enter to continue, any other key to repeat.

```

Figure 4-6. Display Screen 2 of the program that calculates regional deposited dose ratios.

Select one of the following:

1. mouse
2. hamster
3. rat
4. guinea pig
5. rabbit

Select one (1 - 5): 3

Body weight from table 4-4 = 180.00 (g)
 default Minute Volume (VE) = 137.30 (ml)
 default ET surface area = 15.00 (cm²) new value: 12.00(cm²)
 default TB surface area = 22.50 (cm²)
 default PU surface area = 0.34 (m²)

Press Esc key to quit, Enter to continue, any other key to repeat.

Figure 4-7. Display Screen 3 of the computer program that calculates regional deposited dose ratios.

Regional deposited dose ratios

MMAD = 2.30
 Sigma g = 1.80

SPECIES	Body weight(g)	VE(ml)	Extrathoracic SA(cm ²)	dep	Tracheobronchial SA(cm ²)	dep	Pulmonary SA(m ²)	dep
rat	180	137.3	12.000	0.473	22.500	0.058	0.340	0.089
human	70000	13800.0	200.000	0.396	3200.000	0.095	54.000	0.231
RATIO	0.003	0.010	0.060	1.196	0.007	0.610	0.006	0.387
RDDR				0.198		0.863		0.611

	Thoracic SA(m ²)	dep	Total RT SA(m ²)	dep	Extrarespiratory BW(g)	dep
rat	0.342	0.147	0.343	0.620	180	0.620
human	54.320	0.125	54.340	0.721	70000	0.721
RATIO	0.006	1.174	0.006	0.860	0.003	0.860
RDDR		0.713		1.353		3.326

Enter: save screen + new session. Esc: save screen + quit. U. 2.3

Figure 4-8. Display Screen 4 of the computer program that calculates regional deposited dose ratios.

To begin the program, type RDDR in upper or lower case letters. The program will then prompt you to enter the MMAD and σ_g for which you want to calculate an $RDDR_r$ (Figure 4-5). Although most studies do report particle sizes as aerodynamic diameter, some studies do not. **Using incorrect units in the program will result in incorrect estimates of the deposition fraction.** Particle size definitions, a discussion on conversion among units, and guidance on default values when there is inadequate information in a study to determine the MMAD and σ_g are provided in Appendix H.

The second screen (Figure 4-6) will print the default values for the minute volume, the three respiratory tract surface areas, and the body weight for the human. As each one is listed, the user has the option of changing the default value for the calculations. Although the software is written so that default values may be changed, it should be noted that body weight, surface areas, and minute volumes are all inter-related and should be changed so that all values are consistent with each other. It is also not recommended to make changes without being able to provide detailed documentation to support alternative values.

The third screen (Figure 4-7) provides a list of 5 animal species from which one must be selected. The body weight (selected from Table 4-5) must be entered. The program then calculates and lists the default minute volume and the default surface areas. Similar to the humans, any of these values may be changed if desired. The same cautions and caveats for changing human default values apply to the laboratory animals.

In the fourth screen (Figure 4-8), the input parameters are listed; the ratios described in Equation 4-7 are printed; and the calculated RDDRs are listed for the three respiratory tract regions, the thoracic region, the total respiratory tract and for extrarrespiratory effects. This screen may be output to an ASCII file and printed using DOS commands. The "PRINT SCREEN" key will work for a stand-alone PC with its own local printer. Use of the "PRINT SCREEN" key with networks depends on how files are treated in the buffer.

The program may be run sequentially and calculations made by hand to determine an $RDDR_r$ based on a human activity pattern. First, the minute volumes to be included in the activity pattern and the fractional time spent at each minute volume must be determined. Then, the program must be run for each minute volume (keeping all other data the same—

MMAD, σ_g , and surface area for the human, and species, minute volume, and surface area for the animal). Then,

$$RDDR_{r_{[ACT]}} = \frac{a}{t_{[1]} \times \dot{V}_{E_{H[1]}} \times F_{r_{H[1]}} + t_{[2]} \times \dot{V}_{E_{H[2]}} \times F_{r_{H[2]}} + \dots + t_{[n]} \times \dot{V}_{E_{H[n]}} \times F_{r_{H[n]}}} \quad (4-8)$$

where $t_{[i]}$ is the fractional time spent breathing minute volume [i],

$$t_{[1]} + t_{[2]} + \dots + t_{[n]} = 1, \quad \text{and} \quad (4-9)$$

$$a = \frac{(SA_r)_H}{(SA_r)_A} \times \dot{V}_{E_A} \times F_{r_A}. \quad (4-10)$$

All of the needed values can be read from Screen 4. The calculated value, a, should have the same input values (i.e., surface areas, all animal input information) on each Screen 4 generated for the activity pattern, but the human values for deposition ($F_{r_{H[i]}}$) and minute volume ($\dot{V}_{E_{H[i]}}$) will be different.

Although the default normalizing factor used in the program for the respiratory tract RDDR is surface area and the default normalizing factor for the extrapulmonary RDDR is body weight, there are situations in which an alternative normalizing factor might be appropriate. In this case, the deposition ratio and the \dot{V}_E ratio from the 4th screen of the computer program (Figure 4-8) may be multiplied by hand calculations of the normalizing factor in humans divided by the normalizing factor in animals to determine the $RDDR_r$. Alternatively, when the default surface area values are listed in Screens 2 and 3 (Figures 4-6 and 4-7), they may be changed to the values of the new normalizing factor. A caveat when "tricking" the program this way is to pay attention to the units of the normalizing factor. In the program, ET and TB surface areas are entered in cm^2 while the PU surface area is entered in m^2 . The program converts units internally when calculating the TH and total RDDR. Unless the units of the proposed normalizing factor bear the same relationship to one another as the surface areas, the program calculated TH and total RDDR with the alternative normalizing factor will be incorrect. At the present time, because \dot{V}_E calculations depend on entering correct body weight data, if the program is "tricked" by

entering information other than body weight to estimate an extrarrespiratory RDDR, then the correct \dot{V}_E must be used to replace the program calculated "default" \dot{V}_E .

The next two sections provide a summary of the default values used for respiratory tract effects and extrarrespiratory tract effects. As discussed above, details on estimation of the deposition fractions are described in Appendix G.

4.3.5.1 Respiratory Effects

The general dosimetric approach for insoluble particles outlined above provides the basis for estimating HECs. When the toxic effect of interest is in the respiratory tract, the equivalent dose across species is assumed to be the particle mass (mg) per minute per unit surface area (cm^2 or m^2) of the respiratory tract region of concern.

When the toxic effect of interest is in the respiratory tract, the normalizing factor described in Equation 4-7 should be replaced specifically by the surface area (SA) of the respiratory tract region of interest.

$$\text{RDDR}_r = \frac{(10^{-6} \times C_i)_A}{(10^{-6} \times C_i)_H} \times \frac{(\text{SA}_r)_H}{(\text{SA}_r)_A} \times \frac{(\dot{V}_E)_A}{(\dot{V}_E)_H} \times \frac{(F_r)_A}{(F_r)_H} \quad (4-11)$$

The default surface area values are provided in Table 4-4.

It is preferable, when possible, to estimate the RDDR_r for one of the three defined respiratory tract regions (ET, TB, or PU). Sometimes the nature of the effect or the detail of reporting precludes distinguishing between a TB and a PU effect so that an RDDR_r for the TH region would be preferred, or it might be possible only to identify the region of interest as the entire respiratory tract. Either some aggregation must be used in calculating the RDDR_r , or the RDDR_r for the region that results in the most conservative HEC could be selected. There are several techniques to aggregate the deposition information for calculation of TH or total respiratory tract RDDRs. The resulting RDDR can vary substantially, and in some cases the determination of which species is more sensitive (human or laboratory animal) may change. This is due to differences in fractional deposition (reflecting the complexities of the mechanisms governing deposition) in the different regions (see Chapter 3) and to the differences in regional surface areas, which may span several orders of magnitude. The

formula used to calculate the total respiratory tract RDDR ($RDDR_{TOT}$) is given below.

Calculation of the thoracic RDDR ($RDDR_{TH}$) differs only in the exclusion of terms related to the ET region.

First, for each species, regional fractional deposition (F_r) per unit surface area (SA_r) is calculated and weighted by the percent of the respiratory tract (TH region) accounted for by that region.

$$\frac{F_{ET}}{SA_{ET}} \times \frac{SA_{ET}}{SA_{ET} + SA_{TB} + SA_{PU}} \quad (4-12)$$

Then, simplifying this expression and summing over the three (or two in the case of the calculation for the TH region) regions gives

$$\frac{F_{TOT}}{SA_{TOT}} = \frac{F_{ET} + F_{TB} + F_{PU}}{SA_{ET} + SA_{TB} + SA_{PU}}, \quad (4-13)$$

yielding

$$RDDR_{TOT} = \frac{(10^{-6} \times C_i)_A}{(10^{-6} \times C_i)_H} \times \frac{(SA_{TOT})_H}{(SA_{TOT})_A} \times \frac{(\dot{V}_E)_A}{(\dot{V}_E)_H} \times \frac{(F_{TOT})_A}{(F_{TOT})_H}. \quad (4-14)$$

4.3.5.2 Remote (Extrarespiratory) Effects

The respiratory tract might not be the target organ for an inhaled compound. The dose actually delivered to other regions of the body will be affected by metabolism, clearance, and distribution patterns. Particles depositing in the respiratory tract will clear rapidly (ET can be within seconds of inhalation) or slowly (PU clearance may take weeks or months) to the GI tract or be absorbed into the interstitium, lymphatics, or into the blood from the respiratory tract. Once deposited, however, very few particles will clear by exhalation (sneezing or coughing). Therefore, it is not unreasonable to estimate extrarespiratory deposition by total

deposition in the respiratory tract when information on dose delivered to nonrespiratory tract organs is unavailable.

The current default normalizing factor for extrarespiratory effects is body weight. In the case of extrarespiratory effects of particles, the equivalent dose across species is assumed to be the mass of particles (mg) deposited per unit body weight (kg). Until clearance and distribution parameters can be incorporated, it is assumed that 100% of the deposited dose to the entire respiratory system is available for uptake to the systemic circulation. Although this assumption will most likely result in an overestimate of the dose delivered to the extrarespiratory target tissue, it is not possible to predict a priori the impact on the dose ratio and resulting HEC (e.g., if the overestimate is of similar magnitude in both the laboratory species and human, the HEC will be relatively unaffected). Use of deposited dose is more accurate than using exposure concentration, however. Therefore, Equation 4-7 may be rewritten as:

$$RDDR_{ER} = \frac{(10^{-6} \times C_i)_A}{(10^{-6} \times C_i)_H} \times \frac{BW_H}{BW_A} \times \frac{(\dot{V}_E)_A}{(\dot{V}_E)_H} \times \frac{(F_{TOT})_A}{(F_{TOT})_H} \quad (4-15)$$

The default values for body weight are shown in Table 4-5. The body weight for the human is the weight used by the International Commission on Radiological Protection (Snyder et al., 1975) for the Reference Man.

4.3.5.3 Additional Issues for Particle Dosimetry

The $RDDR_r$ for particle exposures consists of components to account for differences between species due to ventilation (\dot{V}_E), the dose metric (surface area, body weight, or other appropriate factor) and predicted regional deposition fractions. Although the use of this dosimetric adjustment provides a step towards more quantitative risk assessment, there are some limitations in the available data which, at present, preclude extension of the model to certain scenarios of interest for risk assessment. As additional information becomes available, the particle dosimetry equations will be refined and updated. This section discusses current recommendations for addressing particle dosimetry when the exposure information is outside the defined conditions for the model.

Hygroscopicity, Solubility, and Nonspherical Particles

The empirical equations used to estimate the predicted regional deposition fractions are derived from exposures using monodisperse, approximately spherical, nonsoluble, and nonhygroscopic particles. The cases outside the defined conditions for the equations include polydisperse particle size distributions, nonspherical particles, and soluble and/or hygroscopic particles. Also, Gerde et al. (1991) have shown that highly lipophilic chemicals and chemicals either absorbed or precipitated onto particles behave fundamentally differently and may require other modeling approaches.

As described in Appendix G, deposition fractions may be estimated for polydisperse spherical particles by integrating the monodisperse deposition fraction over the size distribution of polydisperse particle. The calculations made for this document assume a lognormal particle size distribution (Raabe, 1971). When particle size distribution for an exposure is reported as MMAD and σ_g , it may be assumed that the particle size distribution is described by the lognormal distribution (because MMAD and σ_g are the first two moments for a lognormal distribution). If exact size distribution information is given or the particles are described as coming from a different, well-parameterized distribution, then an exact calculation must be performed.

Nonspherical particles may be described in terms of their equivalent aerodynamic diameter and, if this information is provided, deposition fractions may be calculated as described in this chapter and Appendix G. Deposition fractions may not be calculated using these equations if an aerodynamic diameter is not provided.

Many particles are hygroscopic and/or soluble. Hygroscopic particles may change size, shape, and density as they traverse the warm, humid airways of the respiratory tract. Soluble particles might or might not undergo hygroscopic changes as they travel along the airways. Solubility will change the physicochemical interactions of the particle with the surface upon which it deposits. Hygroscopicity is a phenomenon related to deposition whereas solubility is related to clearance. This discussion, therefore, will focus on hygroscopicity and its potential effects on predicted fractional deposition.

The RDD of a hygroscopic aerosol will often be different from that of nonhygroscopic particles, although both had similar size distributions upon inhalation (Martonen et al., 1985). The factors influencing changes in inhaled hygroscopic particle characteristics are being

studied experimentally and through development and analysis with complex theoretical models (Martonen and Patel, 1981; Martonen, 1982; Ferron and Hornik, 1984; Martonen et al., 1985; Eisner et al., 1990), but application in risk assessment awaits definition of the primary factors influencing hygroscopic growth on species- and agent-specific bases. The factors include initial particle geometry and density, material hygroscopic growth characteristics, respiratory parameters, and temperature and relative humidity profiles. Observations on the data from modeling efforts to date indicate that hygroscopic particles in the diffusion-dominated regime have reduced TH deposition relative to nonhygroscopic particles of identical preinspired size, whereas those hygroscopic particles affected by inertial and gravitational forces have an increase in TH deposition relative to nonhygroscopic particles (Martonen et al., 1985). These observations may be explained by changes in the particle size after inspiration. Accordingly, the calculated deposition efficiency for nonhygroscopic particles would underestimate the TH deposited dose for the larger (affected by inertial and gravitational forces) hygroscopic particles, and overestimate the deposited dose for the smaller diffusion-dependent hygroscopic particles. The TH deposited dose of inhaled nonhygroscopic particles, however, is always less than the initial total dose (exposure dose). Also, the relative changes in deposition will be in a similar direction in experimental animal species and humans. Dosimetric adjustment by the default insoluble (nonhygroscopic) empirical deposition equations is recommended as a conservative default for the hydroscopic particles, pending modification by the elucidation of the hygroscopic models.

Ventilation

It is recognized that this approach is based on deposition efficiency data obtained or derived under a particular set of ventilatory parameters (i.e., the experimental parameters for the laboratory animals and human subjects), coupled with default ventilation parameters (\dot{V}_E). The assumption in this application is that it is valid to linearly extrapolate from these experimental values to the default sets of ventilation parameters. The validity of this assumption is being investigated. The effect of activity pattern on ventilation and the allometric relationships between lung weight, lung surface area, and body weight have been investigated (Adolph, 1949; Weibel, 1972; U.S. Environmental Protection Agency, 1988a;

1993b; Federal Register, 1992b). A discussion of the impact that breathing pattern has on the human deposition estimates can be found elsewhere (Miller et al., 1988).

Differences Between Experimental and Ambient Exposures

The human ambient exposure scenario, when known, may be characterized by a different MMAD and σ_g than that used to derive the health risk assessment. Comparisons between ratios calculated with a MMAD and σ_g the same as the animal exposure and calculated with the human estimate using the anticipated ambient MMAD and σ_g may provide some insight on the uncertainty of this extrapolation.

Clearance and Retention

In addition to inspired air concentration, \dot{V}_E , surface area, and deposition efficiency, the effective dose of inhaled particulate matter will vary with bioavailability. The fraction of particulate matter dissolved and assumed to be bioavailable can be expected to increase with greater particle solubility, as well as with longer residence time in the lungs. Until clearance and distribution parameters can be systematically incorporated, 100% of the deposited dose to the entire respiratory tract is assumed to be available for uptake to the systemic circulation. As discussed, this assumption will most likely result in an overestimate of the dose delivered to the extrapulmonary target tissue, although it is not possible to predict a priori the impact on the dose ratio and resultant HEC. Use of deposited dose is more accurate than using exposure concentration, however. Models have recently been used to simulate clearance and estimate retention in various species (Snipes, 1989a,b; Yu and Yoon, 1990). The EPA has recognized the importance of incorporating clearance components to its dosimetric adjustments in order to calculate regional retained dose ratios (RRDRs) for estimates of long-term lung burdens, but such models for classes of particles and different species used in testing are not fully developed. In those cases where clearance and distribution have been experimentally determined and a validated model exists, the more comprehensive model should be used. For example, the model of Yu and Yoon (1990) was used to calculate the HEC for diesel engine emissions (IRIS, 1992).

Population Variability

The calculation of an $RDDR_T$ currently uses point estimates for all the terms in Equation 4-7 and its variants; that is, a default \dot{V}_E for each species, a default regional surface area, and an estimate of fractional deposition. These single values are assumed to be representative of the average value of that term for a member of the laboratory animal species or human population. In fact, as discussed in Chapter 3, there are many sources of intraspecies variability that contribute to the range of responses observed to a given external exposure to an inhaled toxicant. Host factors affect both the delivered dose of the toxicant to the target tissue and the sensitivity of that tissue to interaction with the toxicant. The procedures described in the preceding sections of this chapter on particle dosimetry provide some limited capabilities to examine the effects of population variability on the $RDDR_T$ by simply changing the default \dot{V}_E and surface areas in an iterative fashion. As indicated in these sections and in Appendix G, however, because of the correlations between \dot{V}_E , surface area, and body weight, such changes should be made with extreme caution. Although the point estimates of the parameters used to predict deposition efficiencies (details in Appendix G) are used to calculate fractional regional deposition, the empirical model also provides estimates of variability that can be used to generate confidence intervals reflective of population variability. Using iterative computational procedures, it is possible to generate envelopes of regional fractional deposition that can be used with distributions of \dot{V}_E , surface areas, and body weights to provide ranges of $RDDR_T$ s. Actual implementation of this procedure is not straightforward due to the complex nature of the correlation structures. In future versions of the dosimetric model used to calculate $RDDR_T$, it should be possible to estimate a distribution for the $RDDR_T$ reflective of population variability in both laboratory animals and humans.

Susceptible Subpopulations

The data used to estimate regional fractional deposition are based on experimental measurements made in healthy laboratory animals and humans breathing under normal or approximately normal conditions. It is recognized that deposition patterns might vary in potentially susceptible subpopulations such as children, the elderly, or people with respiratory diseases (see Chapter 2). Limited data are available at present for fitting deposition

efficiency equations for any of these subpopulations. If it is assumed that the same efficiency relationships may be used, then the model may be used to examine predicted RDDRs (in healthy children, for example) by scaling surface area and ventilation for size. This approach is consistent with deterministic models of deposition in which airway geometry and ventilation are scaled to children's dimensions, but the mechanisms of deposition are unchanged. Although the approaches are consistent, the predicted deposition patterns might vary with measured data.

4.3.6 Dosimetric Adjustments for Gas Exposures

The approach described in Section 4.3.5 for the insoluble particles illustrates the feasibility of interspecies dosimetry calculations to extrapolate the toxicological results of inhaled toxicants to human exposure conditions for dose-response evaluation. Dosimetry data facilitate evaluation of concentration-response data with respect to dose-response relationships. As described in Section 3.2, predictive physiologically-based modeling for relatively insoluble and reactive gases has been demonstrated (Overton and Miller, 1988). Predictive physiologically based modeling has also been demonstrated for gases and vapors of organic solvents that may be metabolically activated (Fiserova-Bergerova, 1983; Andersen et al., 1987a; Overton, 1989), and for reactive and soluble gases (Aharonson et al., 1974; Morgan and Frank, 1977; Hanna et al., 1989; Casanova et al., 1991; Morris and Blanchard, 1992). As discussed in Section 3.2.2, the chemical-specific or class-specific nature of these models has been dictated by the physicochemical characteristics of the subject gases and no single model structure is applicable to the broad range of gases that the RfC methodology must address. A gas categorization scheme was thus developed as a way to create separation between types of gases so that model structures for each type could be developed. The scheme developed in Section 3.2.2 should be used to categorize the type of gas for dosimetric adjustment. The derivation of the model structure and its reduction to a form with a minimal number of parameters as the basis of the default dosimetry adjustments for gases in Category 1 and 2 are presented in Appendix I. The model structure and basis for the default adjustment for gases in Category 3 are presented in Appendix J. The reader is referred to these sections for proper understanding of the framework of default dosimetric equations presented herein.

Consideration also should be given to the discussion by the National Research Council (1986) and Dahl (1990) on interspecies extrapolation based on mechanism of action. Three classes of mechanism were distinguished based on whether the parent compound, stable metabolite, or reactive metabolite produces the toxic effect; measures of dose for each of these classes were suggested. These factors are often species-specific and dose-dependent, as well as being chemical-specific and, therefore, require a substantial data base (beyond that which exists in most circumstances) in order to model comparative species dosimetry of gases based on mechanism of action. O'Flaherty (1989) presented a framework within which to consider measures of delivered dose and discusses procedures for interspecies conversion of kinetically equivalent doses. Identification of the limiting anatomic and physiologic parameters, physicochemical characteristics, and exposure concentration and duration conditions will facilitate the application of these factors to improve the interspecies default dose adjustments. This understanding can also be used to gauge the appropriation of the default adjustments on a case-by-case basis.

Basically, the $RGDR_r$ is used as the DAF_r in Equation 4-3 to dosimetrically adjust the experimental NOAEL to an HEC as

$$NOAEL^*_{[HEC]} \text{ (mg/m}^3\text{)} = NOAEL^*_{[ADJ]} \text{ (mg/m}^3\text{)} \times RGDR_r, \quad (4-16)$$

where:

$NOAEL^*_{[HEC]}$ = the NOAEL or analogous effect level obtained with an alternative approach as described in Appendix A, dosimetrically adjusted to an HEC;

$NOAEL^*_{[ADJ]}$ = is defined in Equation 4-2; and

$RGDR_r$ = $(RGD)_A / (RGD)_H$, the ratio of regional gas dose in laboratory animal species to that of humans for region (r) of interest for the toxic effect.

The default equations to derive the $RGDR_r$ for the different gas categories according to toxicity in the respiratory tract versus remote sites follow in Section 4.3.6.1 and 4.3.6.2, respectively. Because the boundaries between the categories are not definitive (see discussion in Section 3.2.2 and Appendix I), but instead were made to allow derivation of default model

structures, identification of the target effect(s) is used to further define the gas category. Thus, remote (extrarespiratory) effects of Category 1 gases and respiratory effects of Category 3 gases are treated according to the default dosimetric adjustments for each of these respective effects of Category 2 gases (Section 4.3.5 and 4.3.6). The default dosimetric adjustments to derive HEC values for respiratory effects of Category 1 gases are provided in Section 4.3.5. The default dosimetric adjustment to derive HEC values for extrarespiratory effects of Category 3 gases is provided in Section 4.3.6. Note that the gas categorization scheme does not apply to inert gases that exert their effects by reversible "physical" interactions of gas molecules with biomolecules (e.g., "displacement" of oxygen by carbon dioxide or narcosis by some parent compounds). Consideration of the inert gases is discussed in Section 2.1.2.3.

4.3.6.1 Respiratory Effects

The two categories of gases with the greatest potential for respiratory tract effects are gases in Category 1 and 2. Category 1 gases are defined as gases that are highly water-soluble and/or rapidly irreversibly reactive in the respiratory tract. Reactivity is defined to include both the propensity for dissociation as well as the ability to serve as substrate for metabolism in the respiratory tract. Gases in Category 2 are defined as gases that are moderately water-soluble that may be rapidly reversibly reactive or moderately to slowly irreversibly reactive in respiratory tract tissue. Examples of gases in Category 1 are hydrogen fluoride, chlorine, formaldehyde, and the organic acids and esters. Examples of gases in Category 2 are ozone, sulfur dioxide, xylene, propanol, and isoamyl alcohol.

Respiratory Effects—Category 1 Gases

Category 1 gases are distinguished by the property that the gas does not significantly accumulate in the blood which would reduce the concentration driving force into the respiratory tract tissue and hence reduce the absorption rate. This characteristic allowed the default approach to be developed based on the integration of attributes of two empirical models as discussed in Appendix I. The approach takes into account the loss of chemical in the airstream to the upper respiratory tract as it progresses to the lower respiratory tract and

separate equations are provided to calculate dose in each region. The rationale and full derivation of the equations is provided in Appendix I.

Extrathoracic Effects. For Category 1 gases that have an effect in the upper respiratory tract, the following equation is used to calculate the ET regional gas dose ratio (RGDR_{ET}).

$$\text{RGDR}_{\text{ET}} = \frac{(\text{Dose}_{\text{ET}})_{\text{A}}}{(\text{Dose}_{\text{ET}})_{\text{H}}} = \frac{\left(\frac{\dot{V}_{\text{E}}}{\text{SA}_{\text{ET}}}\right)_{\text{A}} \left(1 - e^{-\frac{K_{\text{gET}} \text{SA}_{\text{ET}}}{\dot{V}_{\text{E}}}}\right)_{\text{A}}}{\left(\frac{\dot{V}_{\text{E}}}{\text{SA}_{\text{ET}}}\right)_{\text{H}} \left(1 - e^{-\frac{K_{\text{gET}} \text{SA}_{\text{ET}}}{\dot{V}_{\text{E}}}}\right)_{\text{H}}}, \quad (4-17)$$

where:

- \dot{V}_{E} = minute volume (mL/min = cm³/min),
- SA_{ET} = surface area of the extrathoracic region (cm²), and
- K_{gET} = overall mass transport coefficient in the extrathoracic region (cm/min).
- A, H = subscripts denoting laboratory animal and human, respectively.

When the overall mass transport coefficient in the ET region (K_{gET}) is not known or can not be reasonably approximated with experimental data for either species, the following equation is used to calculate the default RGDR_{ET} (see Section I.2.4.1):

$$\text{RGDR}_{\text{ET}} = \frac{(\text{Dose}_{\text{ET}})_{\text{A}}}{(\text{Dose}_{\text{ET}})_{\text{H}}} \approx \frac{\left(\frac{\dot{V}_{\text{E}}}{\text{SA}_{\text{ET}}}\right)_{\text{A}}}{\left(\frac{\dot{V}_{\text{E}}}{\text{SA}_{\text{ET}}}\right)_{\text{H}}}. \quad (4-18)$$

Tracheobronchial Effects. For Category 1 gases that affect the lower respiratory tract, the scrubbing in the upper airways of the chemical is taken into account, and the concentration of the air exiting the ET region is used in the derivation of dose to the TB region.

The following equation is used to calculate the TB regional gas dose ratio (RGDR_{TB}):

$$\text{RGDR}_{\text{TB}} = \frac{(\text{Dose}_{\text{TB}})_{\text{A}}}{(\text{Dose}_{\text{TB}})_{\text{H}}} = \frac{\left(\frac{\dot{V}_{\text{E}}}{\text{SA}_{\text{TB}}} \right)_{\text{A}}}{\left(\frac{\dot{V}_{\text{E}}}{\text{SA}_{\text{TB}}} \right)_{\text{H}}} \frac{(\text{fp}_{\text{ET}})_{\text{A}}}{(\text{fp}_{\text{ET}})_{\text{H}}} \frac{(1 - e^{-\frac{K_{\text{gTB}} \text{SA}_{\text{TB}}}{\dot{V}_{\text{E}}}})_{\text{A}}}{(1 - e^{-\frac{K_{\text{gTB}} \text{SA}_{\text{TB}}}{\dot{V}_{\text{E}}}})_{\text{H}}}, \quad (4-19)$$

where:

SA_{TB} = surface area of the tracheobronchial region (cm²),

K_{gTB} = overall mass transport coefficient in the tracheobronchial region (cm/min),
and

fp_{ET} = the fraction of inhaled chemical concentration penetrating the ET region and thereby available for uptake in the TB region, calculated as

$$\text{fp}_{\text{ET}} = e^{-\frac{K_{\text{gET}} \text{SA}_{\text{ET}}}{\dot{V}_{\text{E}}}}. \quad (4-20)$$

If the penetration fraction is unknown due to the lack of data on K_{gTB} , it is reasonable to assume that K_{g} is large, which is consistent with the definition of Category 1 gases, such that the exponential term of Equation 4-19 reduces to zero. The same result may be achieved by determining the conditions in which the third ratio of the right hand side of Equation 4-19 reduces to 1. These conditions will be a function of the default values for respiratory tract surface area and minute volume as well as the absolute value of the overall mass transport coefficient. Using the definition of fp_{ET} results in the following dose ratio:

$$\text{RGDR}_{\text{TB}} = \frac{(\text{RGD}_{\text{TB}})_{\text{A}}}{(\text{RGD}_{\text{TB}})_{\text{H}}} = \frac{\left(\frac{\dot{V}_{\text{E}}}{\text{SA}_{\text{TB}}} \right)_{\text{A}}}{\left(\frac{\dot{V}_{\text{E}}}{\text{SA}_{\text{TB}}} \right)_{\text{H}}} \frac{\left(e^{-K_{\text{gET}} \frac{\text{SA}_{\text{ET}}}{\dot{V}_{\text{E}}}} \right)_{\text{A}}}{\left(e^{-K_{\text{gET}} \frac{\text{SA}_{\text{ET}}}{\dot{V}_{\text{E}}}} \right)_{\text{H}}} \quad (4-21)$$

When the overall mass transport coefficient in the extrathoracic region (K_{gET}) is not known or can not be reasonably approximated with experimental data for either species, K_{gET} is further assumed to be one, and Equation 4-21 reduces further such that only minute volume and surface areas are needed to evaluate the dose ratio:

$$\text{RGDR}_{\text{TB}} = \frac{(\text{RGD}_{\text{TB}})_{\text{A}}}{(\text{RGD}_{\text{TB}})_{\text{H}}} = \frac{\left(\frac{\dot{V}_{\text{E}}}{\text{SA}_{\text{TB}}} \right)_{\text{A}}}{\left(\frac{\dot{V}_{\text{E}}}{\text{SA}_{\text{TB}}} \right)_{\text{H}}} \frac{\left(e^{-\frac{\text{SA}_{\text{ET}}}{\dot{V}_{\text{E}}}} \right)_{\text{A}}}{\left(e^{-\frac{\text{SA}_{\text{ET}}}{\dot{V}_{\text{E}}}} \right)_{\text{H}}} \quad (4-22)$$

If K_{gET} is available for each species, Equation 4-21 would be the preferred default equation.

Pulmonary Effects. The gas concentration that reaches the PU region was affected by the amount of uptake in both the ET and TB regions so that the derivation for the PU gas dose ratio (RGDR_{PU}) incorporates the penetration fraction both for the ET and TB regions, respectively. The following equation is used to calculate RGDR_{PU} :

$$\text{RGDR}_{\text{PU}} = \frac{(\text{Dose}_{\text{PU}})_{\text{A}}}{(\text{Dose}_{\text{PU}})_{\text{H}}} = \frac{\left(\frac{K_{\text{gPU}} \text{SA}_{\text{PU}}}{K_{\text{gPU}} \text{SA}_{\text{PU}} + \dot{Q}_{\text{alv}}} \right)_{\text{A}}}{\left(\frac{K_{\text{gPU}} \text{SA}_{\text{PU}}}{K_{\text{gPU}} \text{SA}_{\text{PU}} + \dot{Q}_{\text{alv}}} \right)_{\text{H}}} \frac{\left(\frac{\dot{Q}_{\text{alv}}}{\text{SA}_{\text{PU}}} \right)_{\text{A}}}{\left(\frac{\dot{Q}_{\text{alv}}}{\text{SA}_{\text{PU}}} \right)_{\text{H}}} \frac{(f_{\text{pTB}})_{\text{A}}}{(f_{\text{pTB}})_{\text{H}}} \frac{(f_{\text{pET}})_{\text{A}}}{(f_{\text{pET}})_{\text{H}}} \quad (4-23)$$

where:

$$\dot{Q}_{\text{alv}} = \text{alveolar ventilation rate (mL/min} = \text{cm}^3\text{/min),}$$

- SA_{PU} = surface area of the pulmonary region (cm^2),
 K_{gPU} = overall mass transport coefficient in the pulmonary region (cm/min),
 fp_{ET} = the fraction of inhaled chemical concentration penetrating the extrathoracic region and thereby available for uptake in the tracheobronchial region, calculated as in Equation 4-20, and
 fp_{TB} = the fraction of inhaled chemical concentration penetrating the tracheobronchial region and thereby available for uptake in the pulmonary region, calculated as

$$fp_{TB} = \frac{CX_{TB}}{CX_{ET}} = e^{-\frac{K_{gTB} SA_{TB}}{\dot{V}_E}} \quad (4-24)$$

where:

- CX_{ET} = the concentration exiting the extrathoracic region, and
 CX_{TB} = the concentration exiting the tracheobronchial region.

At large K_{gPU} values, Equation 4-23 reduces to

$$RGDR_{PU} = \frac{(RGD_{PU})_A}{(RGD_{PU})_H} = \frac{\left[\frac{\dot{Q}_{alv}}{SA_{PU}} \right]_A}{\left[\frac{\dot{Q}_{alv}}{SA_{PU}} \right]_H} \frac{(fp_{TB})_A}{(fp_{TB})_H} \frac{(fp_{ET})_A}{(fp_{ET})_H}. \quad (4-25)$$

If the penetration fractions to each of the preceding regions are unknown due to lack of data on K_{gET} and K_{gTB} , the approach to deriving a default equation for the PU region is described below.

Using the definition of fp_{ET} and fp_{TB} results in the following PU region gas dose ratio:

$$\text{RGDR}_{\text{PU}} = \frac{(\text{RGD}_{\text{PU}})_{\text{A}}}{(\text{RGD}_{\text{PU}})_{\text{H}}} = \frac{\left(\frac{\dot{Q}_{\text{alv}}}{\text{SA}_{\text{PU}}}\right)_{\text{A}}}{\left(\frac{\dot{Q}_{\text{alv}}}{\text{SA}_{\text{PU}}}\right)_{\text{H}}} \frac{\left(e^{-\frac{K_{\text{gTB}} \text{SA}_{\text{TB}}}{\dot{V}_{\text{E}}}}\right)_{\text{A}}}{\left(e^{-\frac{K_{\text{gTB}} \text{SA}_{\text{TB}}}{\dot{V}_{\text{E}}}}\right)_{\text{H}}} \frac{\left(e^{-\frac{K_{\text{gET}} \text{SA}_{\text{ET}}}{\dot{V}_{\text{E}}}}\right)_{\text{A}}}{\left(e^{-\frac{K_{\text{gET}} \text{SA}_{\text{ET}}}{\dot{V}_{\text{E}}}}\right)_{\text{H}}}, \quad (4-26)$$

which can be rearranged to

$$\text{RGDR}_{\text{PU}} = \frac{(\text{RGD}_{\text{PU}})_{\text{A}}}{(\text{RGD}_{\text{PU}})_{\text{H}}} = \frac{\left(\frac{\dot{Q}_{\text{alv}}}{\text{SA}_{\text{PU}}}\right)_{\text{A}}}{\left(\frac{\dot{Q}_{\text{alv}}}{\text{SA}_{\text{PU}}}\right)_{\text{H}}} \frac{\left(e^{-\frac{\text{SA}_{\text{TB}}}{\dot{V}_{\text{E}}}\right)^{(K_{\text{gTB}})_{\text{A}}}}{\left(e^{-\frac{\text{SA}_{\text{TB}}}{\dot{V}_{\text{E}}}\right)^{(K_{\text{gTB}})_{\text{H}}}} \frac{\left(e^{-\frac{\text{SA}_{\text{ET}}}{\dot{V}_{\text{E}}}\right)^{(K_{\text{gET}})_{\text{A}}}}{\left(e^{-\frac{\text{SA}_{\text{ET}}}{\dot{V}_{\text{E}}}\right)^{(K_{\text{gET}})_{\text{H}}}}. \quad (4-27)$$

If $(K_{\text{gET}})_{\text{A}}$ and $(K_{\text{gTB}})_{\text{A}}$ are assumed to be equal to $(K_{\text{gET}})_{\text{H}}$ and $(K_{\text{gTB}})_{\text{H}}$, respectively, then Equation 4-27 can be further simplified to

$$\text{RGDR}_{\text{PU}} = \frac{(\text{RGD}_{\text{PU}})_{\text{A}}}{(\text{RGD}_{\text{PU}})_{\text{H}}} = \frac{\left(\frac{\dot{Q}_{\text{alv}}}{\text{SA}_{\text{PU}}}\right)_{\text{A}}}{\left(\frac{\dot{Q}_{\text{alv}}}{\text{SA}_{\text{PU}}}\right)_{\text{H}}} \frac{\left(e^{-\frac{\text{SA}_{\text{TB}}}{\dot{V}_{\text{E}}}\right)^{(K_{\text{gTB}})_{\text{A}}}}{\left(e^{-\frac{\text{SA}_{\text{TB}}}{\dot{V}_{\text{E}}}\right)^{(K_{\text{gTB}})_{\text{H}}}} \frac{\left(e^{-\frac{\text{SA}_{\text{ET}}}{\dot{V}_{\text{E}}}\right)^{(K_{\text{gET}})_{\text{A}}}}{\left(e^{-\frac{\text{SA}_{\text{ET}}}{\dot{V}_{\text{E}}}\right)^{(K_{\text{gET}})_{\text{H}}}} \quad (4-28)$$

If it is further assumed that the value of K_{g} is equal to 1 for each region, the resulting default equation (Equation 4-28) reduces to an equation requiring only surface area and \dot{V}_{E} parameters. It should be noted that as comparative transport studies become available, Equation 4-27 would be preferable because it includes the differences in mass transport in each region for each species.

Respiratory Effects—Category 2 Gases

Category 2 or "transitional" gases have the potential for significant accumulation in the blood and thus have the potential for both respiratory and remote (extrathoracic) toxicity. The accumulation in the blood will reduce the concentration driving force during inspiration and thereby reduce the absorption rate or dose upon inhalation. They also have the potential for significant desorption during exhalation. The model structure used as the basis for the default dosimetric adjustment for Category 1 gases was insufficient for addressing this property and a hybrid structure between that for Category 1 and Category 3 gases was constructed. The rationale and full derivation of the equations is provided in Appendix I. The default dosimetric adjustments for respiratory tract effects of Category 2 gases is presented below and those for dosimetric adjustment of remote toxicity are provided in Section 4.3.6.2.

Extrathoracic Effects. For Category 2 gases, the ET regional gas dose ratio ($RGDR_{ET}$) is given by

$$RGDR_{ET} = \frac{(RGD_{ET})_A}{(RGD_{ET})_H} = \frac{\left(\frac{C_i \dot{V}_E}{SA_{ET}}\right)_A \left(1 - \frac{C_{b/g}}{C_i}\right)_A \left(1 - e^{-K_{gET} \frac{SA_{ET}}{\dot{V}_E}}\right)_A}{\left(\frac{C_i \dot{V}_E}{SA_{ET}}\right)_H \left(1 - \frac{C_{b/g}}{C_i}\right)_H \left(1 - e^{-K_{gET} \frac{SA_{ET}}{\dot{V}_E}}\right)_H} \quad (4-29)$$

where:

C_i = inhaled concentration ($\text{mg}/\text{cm}^3 = 10^{-6} \text{ mg}/\text{m}^3$), and

$C_{b/g}$ = gas concentration in equilibrium with blood concentration (mg/m^3).

However, K_{gET} for Category 2 gases is by definition less than 1. Assuming K_{gET} is equal to or less than 0.5, a power series expansion of the exponential term results in the following relationship:

$$\text{RGDR}_{\text{ET}} = \frac{(\text{RGD}_{\text{ET}})_{\text{A}}}{(\text{RGD}_{\text{ET}})_{\text{H}}} = \frac{(C_i \frac{\dot{V}_E}{SA_{\text{ET}}})_{\text{A}} (1 - \frac{C_{\text{b/g}}}{C_i})_{\text{A}} (-K_{\text{gET}} \frac{SA_{\text{ET}}}{\dot{V}_E})_{\text{A}}}{(C_i \frac{\dot{V}_E}{SA_{\text{ET}}})_{\text{H}} (1 - \frac{C_{\text{b/g}}}{C_i})_{\text{H}} (-K_{\text{gET}} \frac{SA_{\text{ET}}}{\dot{V}_E})_{\text{H}}}. \quad (4-30)$$

Assuming the same inspired concentration, simplifies the RGDR_{ET} to

$$\text{RGDR}_{\text{ET}} = \frac{(\text{RGD}_{\text{ET}})_{\text{A}}}{(\text{RGD}_{\text{ET}})_{\text{H}}} = \frac{K_{\text{gETA}}}{K_{\text{gETH}}} \frac{(1 - \frac{C_{\text{b/g}}}{C_i})_{\text{A}}}{(1 - \frac{C_{\text{b/g}}}{C_i})_{\text{H}}}. \quad (4-31)$$

If the overall mass transport coefficients (K_{gET}) are assumed equal as in the case of Category 1 gases, the RGDR_{ET} is reduced to the ratio of the blood term $(1 - C_{\text{b/g}}/C_i)$.

Two cases were developed for the derivation of the blood term (see Appendix I). The first case assumes systemic elimination is much greater than respiratory tract metabolism such that

$$\text{RGDR}_{\text{ET}} = \frac{(\text{RGD}_{\text{ET}})_{\text{A}}}{(\text{RGD}_{\text{ET}})_{\text{H}}} = \frac{K_{\text{gETA}}}{K_{\text{gETH}}} \frac{(0.25 \dot{Q}_T H_{\text{b/g}})_{\text{A}}}{(0.25 \dot{Q}_T H_{\text{b/g}})_{\text{H}}}, \quad (4-32)$$

and the second case where the respiratory tract metabolism is of equal significance to systemic elimination such that

$$\text{RGDR}_{\text{ET}} = \frac{(\text{RGD}_{\text{ET}})_{\text{A}}}{(\text{RGD}_{\text{ET}})_{\text{H}}} = \frac{K_{\text{gETA}}}{K_{\text{gETH}}} \frac{(0.5 \dot{Q}_T H_{\text{b/g}})_{\text{A}}}{(0.5 \dot{Q}_T H_{\text{b/g}})_{\text{H}}}, \quad (4-33)$$

where E_{MAX} , the maximum extraction efficiency, is equal to $0.25 \dot{Q}_T$ and $H_{b/g}$ is the blood:gas (air) partition coefficient of the chemical. Because the constants are equal in the numerator and denominator, Equations 4-32 and 4-33 reduce to the same equation. Thus, the default regional gas dose ratio for ET effects of Category 2 gases is:

$$RGDR_{ET} = \frac{(RGD_{ET})_A}{(RGD_{ET})_H} = \frac{K_{gETA}}{K_{gETH}} \frac{(\dot{Q}_T H_{b/g})_A}{(\dot{Q}_T H_{b/g})_H} \quad (4-34)$$

Equation 4-34 can be further reduced by the assumption that the overall mass transport coefficients (K_{gET}) are equal when these values are not available. The value of 1.0 is used for the ratio of $(H_{b/g})_A / (H_{b/g})_H$ if $(H_{b/g})_A > (H_{b/g})_H$ or if these partition coefficient values are unknown. Gargas et al. (1989) and Jepson et al. (1994) provide discussion of techniques to derive partition coefficients and report values for volatile and nonvolatile chemicals, respectively.

Tracheobronchial Effects. The TB regional gas dose ratio ($RGDR_{TB}$) for Category 2 gases is given by

$$RGDR_{TB} = \frac{(RGD_{TB})_A}{(RGD_{TB})_H} = \frac{(C_i \frac{\dot{V}_E}{SA_{TB}})_A}{(C_i \frac{\dot{V}_E}{SA_{TB}})_H} \frac{(e^{-K_{gET} \frac{SA_{ET}}{\dot{V}_E}})_A}{(e^{-K_{gET} \frac{SA_{ET}}{\dot{V}_E}})_H} \frac{(1 - \frac{C_{b/a}}{C_i})_A}{(1 - \frac{C_{b/a}}{C_i})_H} \frac{(1 - e^{-K_{gTB} \frac{SA_{TB}}{\dot{V}_E}})_A}{(1 - e^{-K_{gTB} \frac{SA_{TB}}{\dot{V}_E}})_H} \quad (4-35)$$

As in the ET region, K_{gTB} for Category 2 gases is by definition less than 1 and a power series expansion of the exponential term for the TB region similarly reduces the last term on the right hand side to the animal-to-human ratio of $K_{gTB} (SA_{TB}/\dot{V}_E)$. The exponential term for the ET term in Equation 4-35 is reduced by assuming K_{gET} is the same for each species as was assumed for Category 1 gases. At values of K_{gET} less than or equal 0.5, the

ET exponential term approaches one. Thus, assuming the same inspired concentrations, Equation 4-35 becomes

$$\text{RGDR}_{\text{TB}} = \frac{(\text{RGD}_{\text{TB}})_{\text{A}}}{(\text{RGD}_{\text{TB}})_{\text{H}}} = \frac{K_{g_{\text{TB}A}}}{K_{g_{\text{TB}H}}} \frac{\left(1 - \frac{C_{b/a}}{C_i}\right)_{\text{A}}}{\left(1 - \frac{C_{b/a}}{C_i}\right)_{\text{H}}} . \quad (4-36)$$

As above for the ET region, the case in which systemic elimination predominates is given by:

$$\text{RGDR}_{\text{TB}} = \frac{(\text{RGD}_{\text{TB}})_{\text{A}}}{(\text{RGD}_{\text{TB}})_{\text{H}}} = \frac{K_{g_{\text{TB}A}}}{K_{g_{\text{TB}H}}} \frac{(0.25 \dot{Q}_T H_{b/a})_{\text{A}}}{(0.25 \dot{Q}_T H_{b/a})_{\text{H}}} , \quad (4-37)$$

and the case in which respiratory tract metabolism and systemic elimination are of equal significance is given by:

$$\text{RGDR}_{\text{TB}} = \frac{(\text{RGD}_{\text{TB}})_{\text{A}}}{(\text{RGD}_{\text{TB}})_{\text{H}}} = \frac{K_{g_{\text{TB}A}}}{K_{g_{\text{TB}H}}} \frac{(0.5 \dot{Q}_T H_{b/a})_{\text{A}}}{(0.5 \dot{Q}_T H_{b/a})_{\text{H}}} , \quad (4-38)$$

where E_{MAX} is equal to $0.25 \dot{Q}_T$. Because the constants are equal in the numerator and denominator, Equations 4-37 and 4-38 reduce to the same equation. Thus, the default regional gas dose ratio for TB effects of Category 2 gases is

$$\text{RGDR}_{\text{TB}} = \frac{(\text{RGD}_{\text{TB}})_{\text{A}}}{(\text{RGD}_{\text{TB}})_{\text{H}}} = \frac{K_{g_{\text{TB}A}}}{K_{g_{\text{TB}H}}} \frac{(\dot{Q}_T H_{b/a})_{\text{A}}}{(\dot{Q}_T H_{b/a})_{\text{H}}} . \quad (4-39)$$

Equation 4-39 can be further reduced by the assumption that the overall mass transport coefficients ($K_{g_{\text{TB}}}$) are equal when these values are not available. The value of 1.0 is used for the ratio of $(H_{b/g})_{\text{A}} / (H_{b/g})_{\text{H}}$ if $(H_{b/g})_{\text{A}} > (H_{b/g})_{\text{H}}$ or if these partition coefficient values are unknown. Gargas et al. (1989) and Jepson et al. (1994) provide discussion of techniques

to derive partition coefficients and report values for volatile and nonvolatile chemicals, respectively.

Pulmonary Effects. The PU regional gas dose ratio (RGDR_{PU}) for Category 2 gases is given by

$$\text{RGDR}_{\text{PU}} = \frac{(\text{RGD}_{\text{PU}})_{\text{A}}}{(\text{RGD}_{\text{PU}})_{\text{H}}} = \frac{(C_i \frac{\dot{Q}_{\text{alv}}}{\text{SA}_{\text{PU}}})_{\text{A}} (e^{-K_{\text{ET}} \frac{\text{SA}_{\text{ET}}}{\dot{V}_{\text{E}}}})_{\text{A}} (e^{-K_{\text{TB}} \frac{\text{SA}_{\text{TB}}}{\dot{V}_{\text{E}}}})_{\text{A}} (1 - \frac{C_{\text{b/a}}}{C_i})_{\text{A}}}{(C_i \frac{\dot{Q}_{\text{alv}}}{\text{SA}_{\text{PU}}})_{\text{H}} (e^{-K_{\text{ET}} \frac{\text{SA}_{\text{ET}}}{\dot{V}_{\text{E}}}})_{\text{H}} (e^{-K_{\text{TB}} \frac{\text{SA}_{\text{TB}}}{\dot{V}_{\text{E}}}})_{\text{H}} (1 - \frac{C_{\text{b/a}}}{C_i})_{\text{H}}} \quad (4-40)$$

The default ratio is obtained by assuming the mass transport coefficients for the ET and the TB region are the same in each species. At values of $K_{\text{gTB}} \leq 0.5$, as per the definition for Category 2 gases, the exponential term for both the ET and TB term in Equation 4-40 reduces to 1.0. Thus, assuming the same inspired concentrations, Equation 4-40 becomes

$$\text{RGDR}_{\text{PU}} = \frac{(\text{RGD}_{\text{PU}})_{\text{A}}}{(\text{RGD}_{\text{PU}})_{\text{H}}} = \frac{(\frac{\dot{Q}_{\text{alv}}}{\text{SA}_{\text{PU}}})_{\text{A}} (1 - \frac{C_{\text{b/a}}}{C_i})_{\text{A}}}{(\frac{\dot{Q}_{\text{alv}}}{\text{SA}_{\text{PU}}})_{\text{H}} (1 - \frac{C_{\text{b/a}}}{C_i})_{\text{H}}} \quad (4-41)$$

The RGDR_{PU} must be evaluated for both cases described above for the ET and TB regions. In the case where systemic elimination determines the blood term, the ratio is given by

$$\text{RGDR}_{\text{PU}} = \frac{(\text{RGD}_{\text{PU}})_{\text{A}} (\frac{\dot{Q}_{\text{alv}}}{\text{SA}_{\text{PU}}})_{\text{A}} (0.25 \dot{Q}_{\text{T}} H_{\text{b/g}})_{\text{A}}}{(\text{RGD}_{\text{PU}})_{\text{H}} (\frac{\dot{Q}_{\text{alv}}}{\text{SA}_{\text{PU}}})_{\text{H}} (0.25 \dot{Q}_{\text{T}} H_{\text{b/g}})_{\text{H}}} \quad (4-42)$$

In the case where respiratory tract metabolism and systemic elimination are equally important, the ratio is given by

$$\text{RGDR}_{\text{PU}} = \frac{(\text{RGD}_{\text{PU}})_{\text{A}}}{(\text{RGD}_{\text{PU}})_{\text{H}}} = \frac{\left(\frac{\dot{Q}_{\text{alv}}}{\text{SA}_{\text{PU}}}\right)_{\text{A}} (0.5 \dot{Q}_{\text{T}} H_{\text{b/g}})_{\text{A}}}{\left(\frac{\dot{Q}_{\text{alv}}}{\text{SA}_{\text{PU}}}\right)_{\text{H}} (0.5 \dot{Q}_{\text{T}} H_{\text{b/g}})_{\text{H}}} \quad (4-43)$$

Because the constants are equal in the numerator and denominator, Equations 4-42 and 4-43 the same equation. Thus, the default regional gas dose ratio for PU effects of Category 2 gases is:

$$\text{RGDR}_{\text{PU}} = \frac{(\text{RGD}_{\text{PU}})_{\text{A}}}{(\text{RGD}_{\text{PU}})_{\text{H}}} = \frac{\left(\frac{\dot{Q}_{\text{alv}}}{\text{SA}_{\text{PU}}}\right)_{\text{A}} (\dot{Q}_{\text{T}} H_{\text{b/g}})_{\text{A}}}{\left(\frac{\dot{Q}_{\text{alv}}}{\text{SA}_{\text{PU}}}\right)_{\text{H}} (\dot{Q}_{\text{T}} H_{\text{b/g}})_{\text{H}}} \quad (4-44)$$

The value of 1.0 is used for the ratio of $(H_{\text{b/g}})_{\text{A}} / (H_{\text{b/g}})_{\text{H}}$ if $(H_{\text{b/g}})_{\text{A}} > (H_{\text{b/g}})_{\text{H}}$ or if these partition coefficient values are unknown. Gargas et al. (1989) and Jepson et al. (1994) provide discussion of techniques to derive partition coefficients and report values for volatile and nonvolatile chemicals, respectively.

4.3.6.2 Remote (Extrarespiratory) Effects

As discussed above in Section 4.3.6.2, Category 2 gases have physicochemical characteristics that result in the potential for significant accumulation of the gas in the blood. Thus, these gases also have the potential to cause remote (extrarespiratory) toxicity at target tissues other than the respiratory tract. Gases or vapors in Category 3 are relatively water insoluble and unreactive in the ET and TB regions. Thus, the relatively limited dose to these respiratory tract regions does not appear to result in any significant toxicity, although some respiratory tract toxicity may be related to recirculation. The uptake of these gases is predominantly in the pulmonary region and is perfusion limited. The site of toxicity is

generally remote to the principal site of absorption in the PU region. An example of a Category 3 gases is styrene.

Remote (Extrarespiratory) Effects—Category 2 Gases

In the event that remote toxicity is associated with a gas in Category 2, the dose to the respiratory tract, and therefore to the blood, is necessary to establish the dose ratio. However, in this case, the surface area of the respiratory tract is irrelevant, only the absorption rate in mass/time (RGD_{RT}) is important such that the dose ratio becomes

$$\frac{(RGD_{RT})_A}{(RGD_{RT})_H} = \frac{(\dot{V}_E)_A}{(\dot{V}_E)_H} \frac{(1 - \frac{C_{b/a}}{C_i})_A}{(1 - \frac{C_{b/a}}{C_i})_H}, \quad (4-45)$$

As in Section 4.3.6.1, this ratio must be evaluated for each of two cases. In the case where systemic elimination determines the blood term, the regional gas dose ratio for remote (extrarespiratory) effects of Category 2 gases is given by

$$RGDR_{ER} = \frac{(RGD_{RT})_A}{(RGD_{RT})_H} = \frac{(\dot{V}_E)_A}{(\dot{V}_E)_H} \frac{(0.25 \dot{Q}_T H_{b/g})_A}{(0.25 \dot{Q}_T H_{b/g})_H}. \quad (4-46)$$

In the case where respiratory tract metabolism and systemic elimination are equally important, the ratio is given by

$$RGDR_{ER} = \frac{(RGD_{RT})_A}{(RGD_{RT})_H} = \frac{(\dot{V}_E)_A}{(\dot{V}_E)_H} \frac{(0.5 \dot{Q}_T H_{b/g})_A}{(0.5 \dot{Q}_T H_{b/g})_H}. \quad (4-47)$$

Because the constants are equal in the numerator and denominator, Equations 4-46 and 4-47 reduce to the same equation. Thus, the default regional gas dose ratio for remote (extrarespiratory) effects of Category 2 gases is:

$$\text{RGDR}_{\text{ER}} = \frac{(\text{RGD}_{\text{RT}})_{\text{A}}}{(\text{RGD}_{\text{RT}})_{\text{H}}} = \frac{(\dot{V}_{\text{E}})_{\text{A}}}{(\dot{V}_{\text{E}})_{\text{H}}} \frac{(\dot{Q}_{\text{T}}H_{\text{b/g}})_{\text{A}}}{(\dot{Q}_{\text{T}}H_{\text{b/g}})_{\text{H}}} . \quad (4-48)$$

The value of 1.0 is used for the ratio of $(H_{\text{b/g}})_{\text{A}} / (H_{\text{b/g}})_{\text{H}}$ if $(H_{\text{b/g}})_{\text{A}} > (H_{\text{b/g}})_{\text{H}}$ or if these partition coefficient values are unknown. Gargas et al. (1989) and Jepson et al. (1994) provide discussion of techniques to derive partition coefficients and report values for volatile and nonvolatile chemicals, respectively.

Remote (Extrarespiratory) Effects-Category 3 Gases

For gases in Category 3 that exhibit their toxic effects outside of the respiratory tract, an approach for the scenario when the concentrations of the gas in the animal is periodic (or could be expected to be) with respect to time is recommended. Derivation of the procedure and Equation 4-48 for estimating $\text{NOAEL}_{[\text{HEC}]s}$ for extrarespiratory effects of these gases is based on a PBPK model described in Appendix J. The procedure will give equivalent or more conservative values for the $\text{NOAEL}_{[\text{HEC}]s}$ than those obtained by using the PBPK model, and can be used with compounds for which modeling would be applicable, but for which some or all values of the important parameters ($H_{\text{b/g}}$, V_{MAX} , K_{M} , etc.) are not available. The approach assumes that physiologic and kinetic processes can be described by a PBPK model, allometric scaling of physiologic and kinetic parameters may be used, and that all concentrations of the inhaled compound in the experimental animal are periodic with respect to time. Based on the PBPK ventilation-perfusion model concept (e.g., Ramsey and Andersen, 1984), algebraic equations that relate organ and tissue compartment concentrations to exposure concentrations under equilibrium conditions were derived for humans; for laboratory animals, equations were derived that relate time average concentrations. Because toxic effects observed in chronic bioassays are the basis for the determination of NOAELs from which RfC values for human exposures are derived, the procedure assumes that chronic laboratory animal exposure scenarios are equivalent to human lifetime exposures. The

procedure also assumes that the toxic effects observed are related to the arterial blood concentration (concentration leaving lung compartment in the model) of the inhaled compound and that $\text{NOAEL}_{[\text{HEC}]^s}$ should be such that the human time-integrated arterial blood concentration is less than or equal to that of the exposed laboratory animal. This latter assumption is equivalent to assuming that the laboratory animal time-averaged arterial blood concentration is equal to the human equilibrium arterial blood concentration. Note that the time average concentrations are the area under the curve over a period divided by the length (time) of a period (e.g., average concentration over 1 week). A mathematical derivation was used to obtain the proposed method of simple algebraic equations to compute $\text{NOAEL}_{[\text{HEC}]^s}$. A more detailed description of the development of the procedure is given in Appendix J.

Another assumption is that the concentrations of the inhaled compound within the animal achieved periodicity with respect to time (i.e., periodic steady state—the concentration versus time profile is the same for every week). An illustration of periodicity is provided in Figure 4-9. Periodicity of the arterial concentration of the agent was not achieved until the sixth week for the plotted theoretical exposure simulation. Practically, the conditions of periodicity should be met during "most" of the exposure duration. For example, if this condition is met for 90% of the time (e.g., periodic during the last 90 weeks of a 100 week experiment), then estimates of average concentrations will be in error by less than 10%.

The following equation is used to calculate an HEC for extrarrespiratory effects of gases in Category 3:

$$\text{NOAEL}^*_{[\text{HEC}]} (\text{mg}/\text{m}^3) = \text{NOAEL}^*_{[\text{ADJ}]} (\text{mg}/\text{m}^3) \times \frac{(\text{H}_{\text{b/g}})_{\text{A}}}{(\text{H}_{\text{b/g}})_{\text{H}}}, \quad (4-48)$$

where:

$\text{NOAEL}^*_{[\text{HEC}]}$ = the NOAEL or analogous effect level obtained with an alternative approach as described in Appendix A, dosimetrically adjusted to an HEC;

$\text{NOAEL}^*_{[\text{ADJ}]}$ = is defined in Equation 4-2; and

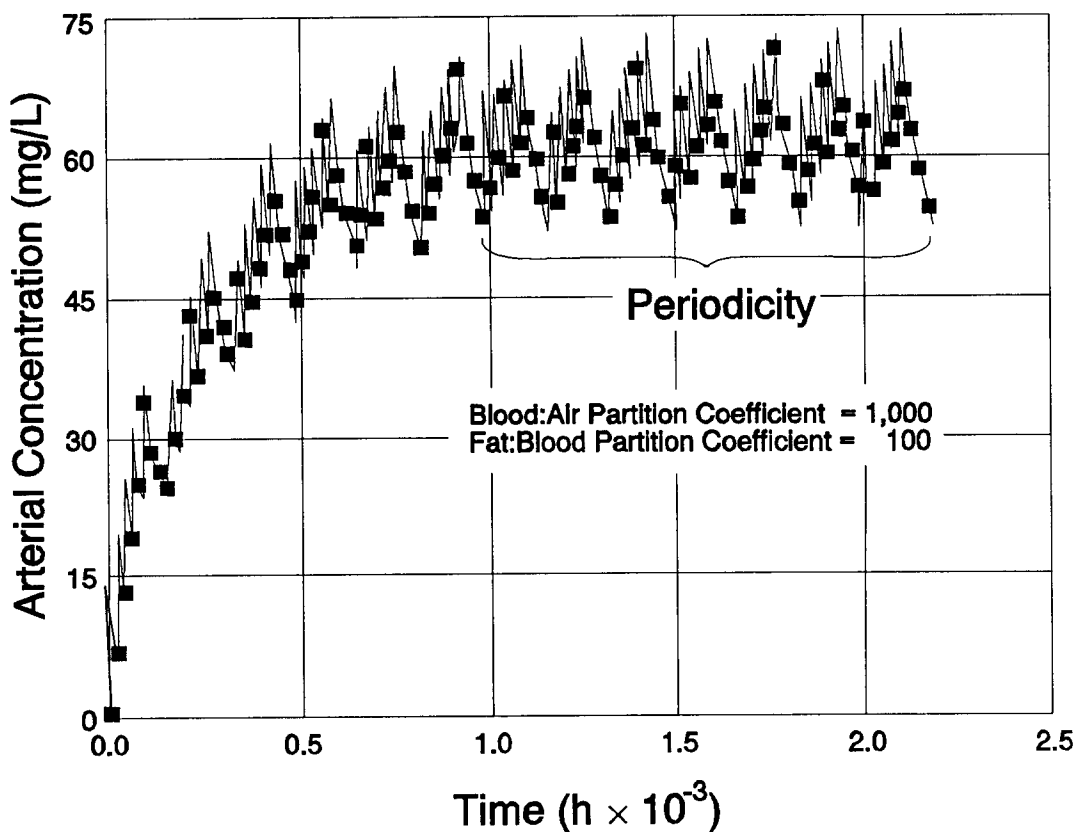

Figure 4-9. Time course of periodicity for F344 rat exposed 6 h/day, 5 days/week to theoretical gas with partition coefficients as shown (Jarabek et al., 1990).

$(H_{b/g})_A / (H_{b/g})_H$ = the ratio of the blood:gas (air) partition coefficient of the chemical for the laboratory animal species to the human value. The value of 1.0 is used for the ratio if $(H_{b/g})_A > (H_{b/g})_H$.

In the case where $H_{b/g}$ values are unknown, the default value of $(H_{b/g})_A / (H_{b/g})_H = 1$ is recommended. An analysis of the available data on rats for blood:air partition coefficients shows that the $(H_{b/g})_A$ is greater than $(H_{b/g})_H$ in most cases. Gargas et al. (1989) and Jepson et al. (1994) provide discussion of techniques to derive partition coefficients and report values for volatile and nonvolatile chemicals, respectively.

Figure 4-10 provides guidance on the relationship of the blood:air and fat:blood partition coefficients with respect to achieving periodicity of an inhaled agent in the arterial blood of a 380-g F344 rat. (It should be noted that often tissue:air partition coefficients are

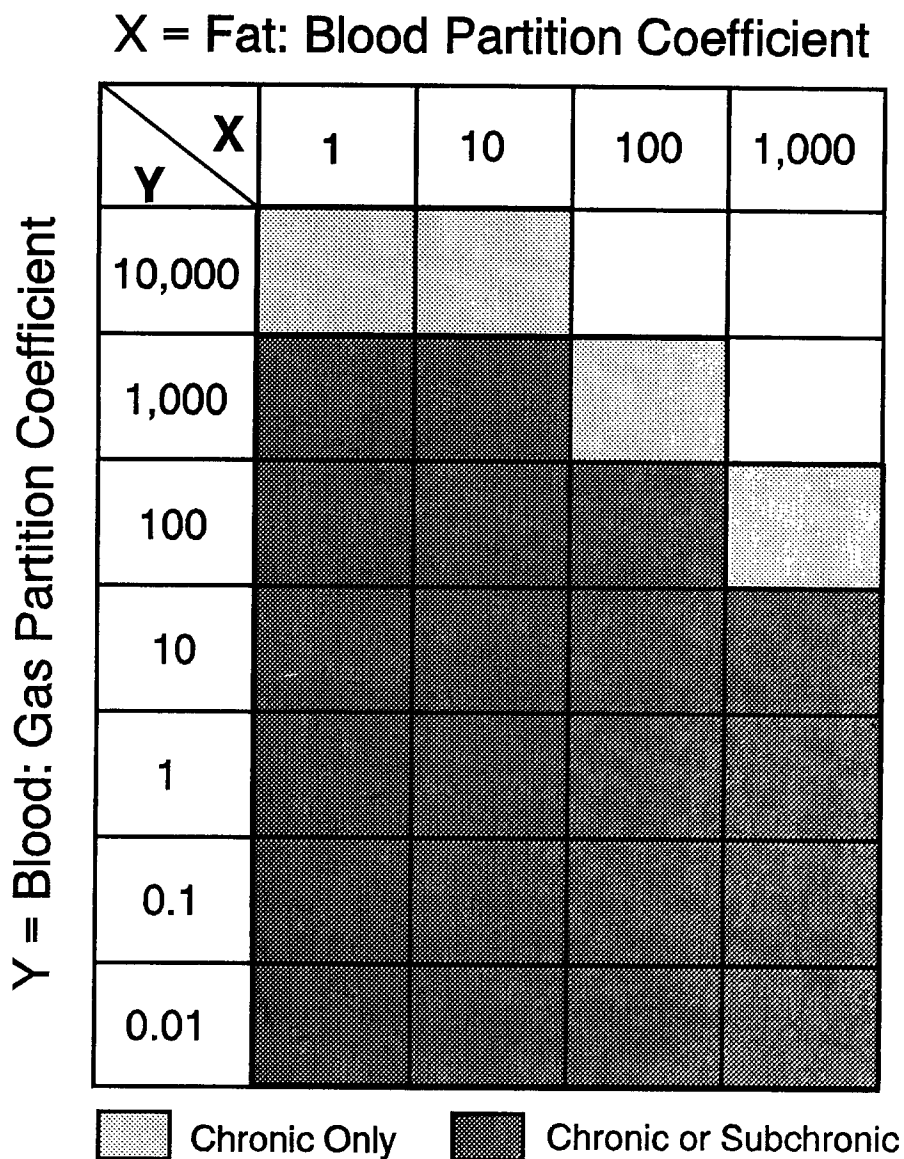

Figure 4-10. Relationship of blood:gas ($H_{b/g}$) and fat:blood partition coefficients to the attainment of periodic blood concentrations in the F344 rat. For a given combination of partition coefficients, the figure indicates (by shading) if simulated blood concentrations reached periodicity within 10% of the exposure time. The exposure regimen was 6 h/day, 5 days/week to 10 ppm. Subchronic = 90 days; chronic = 104 weeks.

reported (e.g., fat:air). The fat:blood partition coefficient can be calculated by dividing the fat:air partition coefficient by the blood:air partition coefficient.) The PBPK model as described in Appendix J was run to simulate a 6 h/day, 5 days/week exposure regimen of

10 ppm. Physiologic parameters, such as ventilation rate, were scaled as described in Appendix J. No metabolic parameters were incorporated in the model for the simulations, because the arterial blood concentration takes longer to reach periodicity without metabolism. Therefore, this figure represents the most conservative values for the partition coefficients for that exposure regimen. The blood:air and fat:blood partition coefficients were chosen based on sensitivity analyses that indicated these two parameters were important to describing the time course of the concentration of an agent in the arterial blood, and upon data availability.

The importance of the relationship between the partition coefficients and the attainment of periodicity is particularly significant when extrapolating from studies of different durations. For example, for an agent with a blood:air partition coefficient of 1,000 and a fat:blood partition coefficient of 100, it would be inappropriate to extrapolate from a subchronic exposure regimen because the criterion of attaining periodicity for 90% of the exposure duration is not met. Periodicity is attained with these same parameters when the study is carried out for a longer duration, however, so that the approach based on the ratio of animal:human partition coefficients can be used on a chronic study without violation of critical assumptions.

Similar matrices to Figure 4-10 can be developed for the relationship between partition coefficients and the attainment of periodicity of the agent in the arterial blood of each experimental species of interest. Use of physiologic parameters for other species and different exposure regimens at various concentrations will influence this relationship and should be considered when determining the extrapolation approach to use for derivation of an HEC.

Since the requirement for achieving periodicity over 90% of the exposure duration is based on the objective of limiting error in the estimate to less than 10%, a modifying factor to account for a greater amount of error should be applied (see Section 4.3.8.1) when the nature of the inhaled agent (e.g., high fat:blood partition coefficient) suggests this condition was not met.

4.3.6.3 Additional Assumptions and Default Values

As with aerosols, after evaluation of the adequacy of the generation system, the initial step in the calculation of HECs is characterization of the exposure.

Gas exposures are characterized by concentration (mg/m^3), temperature, and pressure. If the concentration is expressed in ppm, the actual temperature and pressure should be used to convert the units to mg/m^3 . When the actual temperature and pressure values are not provided in a study, it should be suspect for deficient reporting of important experimental detail. Some studies, however, express values already corrected for these parameters, usually corrected to 25 °C and 760 mm Hg. These values are the recommended default values for temperature and pressure, respectively.

Other assumptions and default values for gas and vapor extrapolations are provided in Appendix J.

4.3.7 Derivation and Dosimetric Adjustment Using Human Studies

Whenever possible, a human study is preferred as the critical study for derivation of an RfC. This avoids the problems of extrapolating from laboratory animals to humans, but has its own limitations. When using epidemiologic data to assess risk in the context of a method designed for data on experimental animals, the dependence of epidemiologic studies on existing exposure conditions and the necessity of using noninvasive diagnostic methods present two complicating factors. One is that existing exposure levels may not include a NOAEL. Toxicologic studies are generally designed to identify the NOAEL. For ethical reasons, many clinical studies in humans often focus on exposure scenarios that are associated with minimal effects and short exposure durations, although they also may identify a NOEL. In contrast, epidemiologic studies cannot be designed as rigorously because exposure levels are dependent on existing exposures. Furthermore, often exposures in epidemiological studies are poorly characterized. In both controlled human and animal studies, the effect level estimates are biased by the dose or exposure level selected or available for study. These effect level estimates are subject to random error, the magnitude of which depends on various design aspects, such as the size of the study population or test groups, and the underlying variability of the test animals or study subjects.

The second factor to consider for epidemiological studies is that a broad spectrum of potential adverse effects cannot be evaluated; therefore, it is difficult to determine the critical effect. Prospective epidemiologic studies that investigate an array of likely biological markers or preclinical endpoints are better sources of NOAELs/LOAELs to estimate the

threshold region. Clinical studies may be based on low exposure levels selected by the investigator and investigate sensitive endpoints, but these studies are generally of short duration and unless mechanisms of action are unequivocally established, are probably more useful for estimating short-term effects or to identify potential target tissues for consideration when evaluating chronic data. The following discussion describes approaches to address the use of human data for RfC derivation.

4.3.7.1 Selecting the Threshold Estimate

In some epidemiologic studies, only severe effects such as mortality are examined so that the concept of a NOAEL is inappropriate for RfC derivation. A study in which sensitive endpoints are evaluated may identify a LOAEL but not a NOAEL. If the effect is sensitive (i.e., it occurs early in the natural history of the disease), a LOAEL may be judged suitable for use in calculating an RfC in lieu of a NOAEL, because the uncertainty of extrapolating human data for a well-defined critical effect from a LOAEL to a NOAEL is judged to be less than the uncertainty involved in extrapolating from animal data to humans. The circumstances governing this selection include deficiency in toxicologic and physiologic data bases, small sample size in the experimental studies, or physiologic or pharmacokinetic data suggesting that animal data are unlikely to be good predictors for humans.

4.3.7.2 Defining the Exposure Level

Epidemiologists cannot control the exposure levels for a study in a systematic fashion, but instead attempt to estimate or measure the levels to which the study population is exposed, insofar as is possible for that study. In actual exposure situations, the levels vary in time and location. Epidemiologic studies can utilize a variety of parameters to characterize exposure, although in retrospective studies the available data are usually quite limited.

The ideal exposure measure for humans who move about in their environment is individual data, such as might be obtained with the use of a personal monitor. However, in addition to the expense and practical difficulties, this technology is available for measuring only a few chemicals. Individual exposure can be constructed by mapping the individual's time in various exposure zones, rooms, or areas. If information on levels in the environment

is not available, duration of employment in a particular job category often is used as a surrogate for exposure.

Parameters commonly used to measure environmental levels are cumulative exposure, peak exposure level, time-weighted average, and ratio of average to peak exposure. Currently, it is unclear which of these is best related to disease. For example, cumulative exposure is more appropriate as the half-life of a substance is increased. Therefore, to derive RfCs that identify levels of environmental exposures free of adverse effects, cumulative exposure or time-weighted averages are appropriate for substances with long half-lives. The circumstances must be evaluated on a case-by-case basis and different exposure parameters may be used if the rationale is presented. For conversion of units, the approach is the same as that for laboratory animal data (Equations 4-1a and 4-1b). Considerations for route-to-route extrapolation would be the same as for laboratory animal data; however, it is highly unlikely that human ingestion data would be available in a form useful for quantitative derivation of an RfC.

4.3.7.3 Dosimetric Adjustment for Human Data

When human data are available and adequate to derive an RfC, adjustments are usually required to account for differences in exposure scenarios (e.g., extrapolation from an 8 h/day occupational exposure to a continuous chronic exposure). The optimal approach is again to use a biologically motivated mathematical or PBPK model. An occupational exposure can be extrapolated in the same fashion as described in Section 4.3.3 to extrapolate intermittent exposure regimens from experimental laboratory animals, using particle deposition or PBPK models with human exertion (work) ventilation rates and exposure durations appropriate to the occupational setting.

In the event that a PBPK model or required physicochemical and physiological parameters are not available, the default approach for human exposure scenarios is to adjust by the default occupational ventilation rate and for the intermittent work week schedule:

$$\text{NOAEL}^*_{[\text{HEC}]} = \text{NOAEL (mg/m}^3) \times (\text{VE}_{\text{ho}}/\text{VE}_{\text{h}}) \times 5 \text{ days} / 7 \text{ days} \quad (4-49)$$

where:

NOAEL*_[HEC] = the NOAEL or analogous effect level obtained with an alternative approach as described in Appendix A, dosimetrically adjusted to an ambient human equivalent concentration;

NOAEL = occupational exposure level (time-weighted average);

VE_{ho} = human occupational default minute volume (10 m³/8 h); and

VE_h = human ambient default minute volume (20 m³/24 h).

4.3.7.4 Uncertainty Factors for Human Data

Areas of extrapolation and the UFs applied to account for them are essentially the same as those for extrapolating laboratory animal data described in Section 4.3.8. The use of human data, in most cases, will obviate only the use of the UF for interspecies extrapolation. The best data to use for calculating an RfC would be a population study of humans that includes sensitive individuals exposed for lifetime or chronic duration, and that evaluates the critical endpoint or an appropriate early marker for the disease. A NOAEL derived from a well done epidemiologic study of this description may require no UF. A similar study in humans that contains only a LOAEL would require the use of a factor of up to 10-fold to reduce the exposure to the range of a NOAEL. Chronic studies on populations that do not include sensitive individuals may require a 10-fold UF. For example, studies of workers are considered to contain only relatively healthy adults. A NOAEL from a study that entails subchronic exposure would require a reduction by a 10-fold UF. However, the amount of exposure in a human study that constitutes subchronic is not defined, and could depend on the nature of the effect and the likelihood of increased severity or greater percent response with duration. In the absence of data on the relationship of animal to human lifespan for predicting health effects, a linear correlation of percent lifespan is sometimes assumed. For example, because a study in animals that is 10% of lifespan is considered subchronic, then 7 years or one-tenth of the assumed human lifetime (70 years) is used as interim guidance for the superfund program to determine the working cut-off for deriving a subchronic human study (Means, 1989). Information on the natural history and progression for the disease should be considered and explained; information on follow-up after exposure, often available in epidemiologic studies, is important.

In some cases, short-term studies of effects in humans can give important information on irritation, sensory effects, or sensitivity and reversibility, yet give no information on the effect of chronic exposure.

4.3.8 Data Array Evaluation and Choice of Principal Study/Studies

Inhalation reference concentrations are typically calculated using a single exposure level and UFs that account for specific deficiencies in the toxicity data base. Both the exposure level and the UFs are selected and evaluated in the context of all available chemical-specific literature. After all toxicological, epidemiologic, and supporting data have been reviewed and evaluated, a principal study (or studies) is selected that reflects optimal data on the critical effect. Dose-response data points for all reported effects are examined as a component of this review. Issues of particular significance in this endeavor include

- A delineation of all toxic effects and associated exposure levels (see Section 4.2).
- Dosimetric adjustment to HEC (see Section 4.3).
- Determination, to the extent possible, of effect-specific experimental threshold regions (i.e., the $\text{NOAEL}_{[\text{HEC}]}$ - $\text{LOAEL}_{[\text{HEC}]}$ interface or bracket).
- Determination of the critical effect. Of the multiple toxic endpoints potentially observed, the critical effect selected is defined as the one associated with the lowest $\text{NOAEL}_{[\text{HEC}]}$ - $\text{LOAEL}_{[\text{HEC}]}$ interface or bracket.
- Special consideration of species, portal-of-entry effects, and/or route-specific differences in pharmacokinetic parameters and the slope of the dose-response curve.

If multiple $\text{NOAEL}_{[\text{HEC}]}$ s for the same critical effect are available in one animal species, the highest $\text{NOAEL}_{[\text{HEC}]}$ for that individual species is compared to $\text{NOAEL}_{[\text{HEC}]}$ s for that effect from other species. If multiple $\text{NOAEL}_{[\text{HEC}]}$ s for the critical effect are available in different species, the lowest of these $\text{NOAEL}_{[\text{HEC}]}$ s, or the $\text{NOAEL}_{[\text{HEC}]}$ for the most sensitive species, generally is selected as the exposure level that most closely defines the threshold for adverse effects of the dose-response curve. When disparity in dose-response patterns is apparent between species, studies need to be evaluated to ascertain, if possible,

whether the differences are due to (1) differences in the monitored endpoints or procedures across studies, (2) species differences in dose-response curves, or (3) choice of dose-spacing (if alternative approaches such as the benchmark or Bayesian approaches described in Appendix A are not used). If species differences are apparent, the question arises as to which species is the most appropriate model for humans. Differences in dose-effect curves could be due to inherent differences in target receptor sensitivity (pharmacodynamics) or to differences in concentration of the compound or metabolite reaching the receptor (pharmacokinetics). This distinction is important when trying to identify the most appropriate species for modeling the human response. Current controversy with respect to the URT in the area of data array analysis involves the relevance of nasal lesions in laboratory rodents versus humans or other primates (DeSesso, 1993) and whether nasal lesions in rodents are somehow sentinel for effects in the lower respiratory tract of primates (Jarabek, 1994). It is consistent with EPA policy to use data on the most sensitive animal species as a surrogate to humans unless data exist to the contrary. In the RfC methodology, this evaluation is based on $NOAEL_{[HEC]}$ s.

Often an appropriate $NOAEL_{[HEC]}$ will not be available. In that event, other estimates of effect-specific thresholds may be used. Based on the dose-effect classification system presented in Tables 4-2 and 4-3, the following guidelines may be employed (adapted from Federal Register, 1980):

- An $FEL_{[HEC]}$ from a study with no other dose-response levels (a free-standing $FEL_{[HEC]}$) is unsuitable for the derivation of an RfC.
- A $NOEL_{[HEC]}$ from a study with no other dose-response levels is unsuitable for the derivation of an RfC. If multiple $NOEL_{[HEC]}$ s are available without additional data, $NOAEL_{[HEC]}$ s, or $LOAEL_{[HEC]}$ s, the highest $NOEL_{[HEC]}$ should be used.
- A $LOAEL_{[HEC]}$ from a study with no other dose-response levels (a free-standing $LOAEL_{[HEC]}$) is unsuitable for the derivation of an RfC.
- A $NOAEL_{[HEC]}$ or $LOAEL_{[HEC]}$ supported by other data may be suitable for RfC derivation. In the case of a $LOAEL_{[HEC]}$, an additional UF is applied for extrapolation to $NOAEL$.

Note: Caution must be exercised not to substitute a $FEL_{[HEC]}$ for a $LOAEL_{[HEC]}$.

- If, for reasonably closely spaced doses, only a $\text{NOEL}_{[\text{HEC}]}$ and a $\text{LOAEL}_{[\text{HEC}]}$ of equal quality are available, then the appropriate uncertainty factor is applied to the $\text{NOEL}_{[\text{HEC}]}$.

In the course of many risk assessment discussions during the last several years, the EPA has decided on the following conditions when choosing the appropriate animal effect or no-effect level as a basis of an RfC. If an appropriate human study with a well-defined $\text{NOAEL}_{[\text{HEC}]}$ is available as to a chemical's critical effect, it is used in preference to laboratory animal toxicity data in estimating RfCs. When such human data are not available, the following sequence is used to choose the appropriate study, species and $\text{NOAEL}_{[\text{HEC}]}$ as a basis of RfC estimation.

- The EPA chooses the most appropriate $\text{NOAEL}_{[\text{HEC}]}$ of the critical effect from a well-conducted study on a species that is known to resemble the human in response to this particular chemical (e.g., by comparative pharmacokinetics).
- When the above condition is not met, the EPA generally chooses the most sensitive study, species, and $\text{NOAEL}_{[\text{HEC}]}$, as judged by an interspecies comparison of the $\text{NOAEL}_{[\text{HEC}]}$ and $\text{LOAEL}_{[\text{HEC}]}$. Table 4-7 outlines examples of this condition.

4.3.9 Operational Derivation of the Inhalation Reference Concentration

Choice of the effect and its associated concentration that serves as the basis for derivation of the RfC requires the evaluation of the entire data array of $\text{NOAEL}_{[\text{HEC}]}$ s and $\text{LOAEL}_{[\text{HEC}]}$ s. An example data array is shown in Figure 4-11. The critical toxic effect to be used in the dose-response assessment is generally the one characterized by the lowest $\text{NOAEL}_{[\text{HEC}]}$ that is representative of the threshold region for the data array. For example, note in Figure 4-11 that as concentration increases above the NOAEL , the incidence or severity of the observed toxicity is also increasing. The objective when analyzing such a data array is to select a prominent toxic effect that is pertinent to the chemical's mechanism of action and which is at or just below the threshold for the relatively more serious effects. This approach is based, in part, on the assumption that if the critical toxic effect is prevented, then all toxic effects are prevented. The determination of the critical toxic effect from all effects in the data array requires toxicologic judgment because a chemical may elicit more

**TABLE 4-7. COMPARISON OF THE HIGHEST INDIVIDUAL SPECIES
NOAEL_[HEC] AND ITS LOAEL_[HEC]^a**

Effect Level (mg/m ³)	Species			Comments (Given the Same Critical Effect)
	Dog	Rat	Mouse	
Example 1:				
LOAEL _[HEC]	100	120	-	The proper choice is generally the highest dog NOAEL _[HEC] of 50 mg/m ³ , since the potential experimental threshold in dogs (i.e., the potential LOAEL _[HEC]) may be below the highest NOAEL _[HEC] s in both rats and mice.
NOAEL _[HEC]	50	60	80	
Example 2:				
LOAEL _[HEC]	120	100	90	The proper choice is generally the mouse LOAEL _[HEC] of 90 mg/m ³ , since the potential experimental threshold in mice may be lower than the highest NOAEL _[HEC] s for both dogs and rats. Judgment is needed in this example to ensure that the adverse effects seen in all three species are truly minimal. For example, if any of the LOAEL _[HEC] s in the species represented an increase in a severe effect, no firm basis for the development of an RfC exists. This is based on the general observation that overt toxicity data are far removed quantitatively from chronic LOAEL _[HEC] s and NOAEL _[HEC] s, and thus, the data base has failed to establish the likely experimental threshold for the most sensitive endpoint.
NOAEL _[HEC]	90	75	-	
Example 3:				
LOAEL _[HEC]	75	80	90	The proper choice is generally the dog LOAEL _[HEC] of 75 mg/m ³ , since by definition this represents the most sensitive species (see, however, the caution in Example 2).
NOAEL _[HEC]	-	-	-	
Example 4:				
LOAEL _[HEC]	-	-	-	The proper choice is generally the highest rat NOAEL _[HEC] of 90 mg/m ³ , since no assurance exists that the experimental threshold in rats is not below the highest NOAEL _[HEC] s of both dogs and mice. This situation is unusual and should be judged carefully; since a LOAEL _[HEC] has not been determined, the RfC may be unduly conservative. Strict interpretation of this example might lead to strikingly lower RfCs if other species are tested at much lower doses. Such RfCs may not be appropriate.
NOAEL _[HEC]	100	90	120	

^aNOAEL_[HEC] or LOAEL_[HEC] refers to NOAEL or LOAEL concentrations adjusted for dosimetric differences between laboratory animals and humans to human equivalent concentrations (HECs).

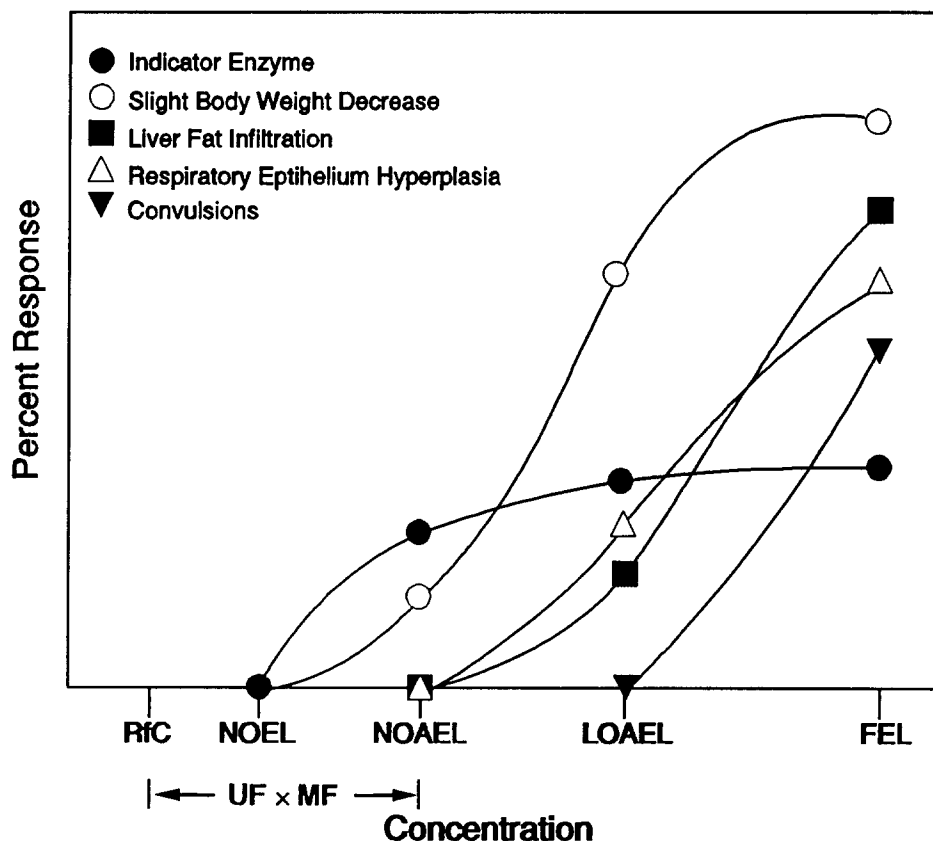

Figure 4-11. Example data array and inhalation reference concentration (RfC) derivation.

than one toxic effect (endpoint) in tests of the same or different exposure duration, even in one test species. Further, as discussed in Appendix A, the $NOAEL_{[HEC]}$ and $LOAEL_{[HEC]}$ obtained from studies depend on the number of laboratory animals or human subjects examined and on the spacing of the exposure levels. The $NOAEL_{[HEC]}$ (or $LOAEL_{[HEC]}$ as discussed above) from an individual study (or constellation of studies), that is also representative of the threshold region for the overall data array is the key datum synthesized from an evaluation of the data array. The study from which this $NOAEL_{[HEC]}$ (or $LOAEL_{[HEC]}$ as discussed above) is estimated is known as the principal study. Determination of the critical effect for the entire data array and identification of the principal study represents the first scientific evaluation of the dose-response analysis per se. The second is the selection of uncertainty factors and operational derivation of the estimate.

4.3.9.1 Application of Uncertainty Factors⁴

The RfC is a benchmark estimate that is derived from the $\text{NOAEL}_{[\text{HEC}]}$ for the critical effect by consistent application of UFs. The UFs are applied to account for recognized uncertainties in the extrapolations from the experimental data conditions to an estimate appropriate to the assumed human scenario. Determination of which UFs to apply and the magnitude of each represents the second scientific evaluation required for an RfC dose-response assessment. The standard UFs applied are those for the following extrapolations (as required): (1) data on effects of average healthy humans to sensitive humans; (2) laboratory animal data to humans; (3) studies of subchronic to chronic duration; (4) a $\text{LOAEL}_{[\text{HEC}]}$ to a $\text{NOAEL}_{[\text{HEC}]}$; and (5) from an incomplete to complete data base. The UFs are generally an order of magnitude, although incorporation of dosimetry adjustments or other mechanistic data has routinely resulted in the use of reduced UFs for RfCs. The composite UF applied to an RfC will vary in magnitude depending on the number of extrapolations required. An RfC will not be derived when use of the data involve greater than four areas of extrapolation, however. The composite UF when four factors are used generally is reduced from 10,000 to 3,000 in recognition of the lack of independence of these factors. This coalescing of several areas of uncertainty is based on the knowledge that each individual factor is generally conservative from the standpoint of the behavior of the average chemical (Dourson and Stara, 1983), and that the multiplication of four or five values of 10 is likely to yield unrealistically conservative RfCs.

An additional modifying factor (MF) may also be applied when scientific uncertainties in the study chosen for derivation are not explicitly addressed by the standard UFs. For example, an MF might be applied to account for a statistically minimal sample size or for poor exposure characterization.

⁴Other authors have discussed these areas of uncertainty or UFs in general. The reader is referred to Zielhuis and Van der Kreek (1979) for a discussion of these factors in setting health-based permissible levels for occupational exposure, and Dourson and Stara (1983) for a summary of these factors regarding oral exposures. Other publications include Gaylor (1983), who discusses the use of safety factors for controlling risk; Crump (1984), who discusses problems with the current methods that includes UFs; Krewski et al. (1984), who contrast safety factors and mathematical models as methods for determining "safe" levels of exposure; Calabrese (1985), who discusses UFs and interindividual variation; and Lu (1983, 1985b), who discusses safety factors from the perspective of the World Health Organization. Lewis et al. (1990) have proposed an operational alternative approach. Renwick (1991) has outlined a flexible scheme based on the nature of toxicity, knowledge of metabolism, and information of human heterogeneity.

Thus, notationally, the RfC is defined as:

$$\text{RfC} = \text{NOAEL}^*_{[\text{HEC}]} / (\text{UF} \times \text{MF}), \quad (4-50)$$

where:

$\text{NOAEL}^*_{[\text{HEC}]}$ = The NOAEL or analogous effect level obtained with an alternate approach as described in Appendix A, dosimetrically adjusted to an HEC;

UF = Uncertainty factor(s) applied to account for the extrapolations required from the characteristics of the experimental regimen; and

MF = Modifying factor to account for scientific uncertainties in the study chosen as the basis for the operational derivation.

It must be emphasized that the RfC as a quantitative dose-response estimate is not numeric alone. As risk assessments have become a more prevalent basis for decision-making, their scientific quality and clarity have gained unprecedented importance (American Industrial Health Council, 1989; National Research Council, 1994). Due to the complexity of many risk assessments, desirable attributes include the explicit treatment of all relevant information and the expression of uncertainty in each element (i.e., hazard identification, dose-response assessment, exposure assessment, and risk characterization). Any dose-response assessment, such as the RfC, has inherent uncertainty and imprecision because the process requires some subjective scientific judgment, use of default assumptions, and data extrapolations.

A complete dose-response evaluation should include communication of the rationale for data selection, the strengths and weaknesses of the data base, key assumptions, and resultant uncertainties (Habicht, 1992; American Conference of Governmental Industrial Hygienists, 1986). The rationale for the choice of the data from which the RfC is derived, a discussion of data gaps, and the resultant confidence in the RfC are all outlined on the summary of the RfC entered on the EPA's Integrated Risk Information System (IRIS). A discussion and rationale for the uncertainty factors used in the RfC derivation are also provided. This information is an important part of the RfC and must be considered when evaluating the RfC as a dose-response estimate, in addition to assumptions and resultant uncertainties inherent in an exposure assessment, when attempting to integrate the assessments into a risk

characterization. Additional guidance on the assignment of confidence levels is provided in Section 4.3.9.2.

Uncertainty factors are associated with various specific recognized uncertainties in extrapolating from the type of study serving as the basis for the RfC to the scenario of interest for the risk assessment as outlined in Table 4-8. The processes thought to be encompassed by each factor are provided in Table 4-9.

An additional MF may be used to account for uncertainties in the study chosen for derivation. For example, a MF may be applied to account for a study of statistically minimal sample size or with poor exposure characterization. The effect of small sample size has long been recognized in toxicology (Bliss, 1938), and recent research has focused on adjusting for this by taking the power of individual studies into account (Brown and Erdreich, 1989). Considerations of the sensitivity of the NOAEL/LOAEL approach to sample size and dose spacing has led to the development of the alternative approaches to derivation discussed in Appendix A.

In general, the choice of UFs applied reflects the uncertainty associated with estimation of an RfC from different human or laboratory animal toxicity data bases. When sufficient human data are available on a chemical's critical effect and pharmacokinetics, the UFs may be smaller than those described in Table 4-8, or unnecessary. For example, if sufficient data from chronic duration exposure studies are available on the threshold region of a chemical's critical toxic effect in a known sensitive human population, then the UF used to estimate the RfC may be 1. That is, these data are judged to be sufficiently predictive of a human population subthreshold dose, so that additional UFs are not needed. Likewise, in cases where data do not completely obviate the uncertainty for which a given UF is applied, or appears to be intermediate in fulfilling that requirement, an intermediate UF is suggested to estimate the RfC (Federal Register, 1980). Composite factors are sometimes applied to account for partial uncertainty under more than one UF. For example, a 10-fold factor may be applied to account for partial uncertainty due to both the use of less than chronic data and a LOAEL, if data supported that the effect was of minimal severity and the lesion did not progress significantly with duration. When a single subchronic study that does not define a NOAEL is the only available information, the EPA recognizes that all five areas of

TABLE 4-8. GUIDELINES FOR THE USE OF UNCERTAINTY FACTORS IN DERIVING INHALATION REFERENCE CONCENTRATION (RFC)

<u>Standard Uncertainty Factors (UFs)</u>	
H	Human to sensitive human Use a 10-fold factor when extrapolating from valid experimental results from studies using prolonged exposure to average healthy humans. This factor is intended to account for the variation in sensitivity among the members of the human population.
A	Animal to human Use an additional threefold factor when extrapolating from valid results of long-term studies on experimental animals when results of studies of human exposure are not available or are inadequate. This factor is intended to account for the uncertainty in extrapolating animal data to the case of average healthy humans. Use of a 3 is recommended with default dosimetric adjustments. More rigorous adjustments may allow additional reduction. Conversely, judgment that the default may not be appropriate could result in an application of a 10-fold factor.
S	Subchronic to chronic Use up to an additional 10-fold factor when extrapolating from less than chronic results on experimental animals or humans when there are no useful long-term human data. This factor is intended to account for the uncertainty in extrapolating from less than chronic NOAELs to chronic NOAELs.
L	LOAEL _[HEC] to NOAEL _[HEC] Use up to an additional 10-fold factor when deriving an RFC from a LOAEL _[HEC] , instead of a NOAEL _[HEC] . This factor is intended to account for the uncertainty in extrapolating from LOAEL _[HEC] s to NOAEL _[HEC] s.
D	Incomplete to complete data base Use up to a 10-fold factor when extrapolating from valid results in experimental animals when the data are "incomplete". This factor is intended to account for the inability of any single animal study to adequately address all potential endpoints at various critical life stages. Unless a comprehensive array of endpoints is addressed by the data base, there is uncertainty as to whether the critical effect chosen for RFC derivation is the most sensitive or appropriate.
<u>Modifying Factor (MF)</u>	
Use professional judgment to determine whether another uncertainty factor (MF) that is ≤10 is needed. The magnitude of the MF depends upon the professional assessment of scientific uncertainties of the study and data base not explicitly treated above (e.g., the number of animals tested or quality of exposure characterization). The default value for the MF is 1.	

NOTE: Assuming the range of the UF is distributed lognormally, reduction of a standard 10-fold UF by half results in a UF of approximately 3 (i.e., 10^{-0.5}). Composite UF for derivation involving four areas of uncertainty is 3,000 in recognition of the lack of independence of these factors. Inhalation reference concentrations are not derived if all five areas of uncertainty are invoked.

TABLE 4-9. THE USE OF UNCERTAINTY FACTORS IN DERIVING AN INHALATION REFERENCE CONCENTRATION

Standard Uncertainty Factors (UFs)	Processes Considered in UF Purview
<p>H = Human to sensitive human Extrapolation of valid experimental results from studies using prolonged exposure to average healthy humans. Intended to account for the variation in sensitivity among the members of the human population.</p>	<p>Pharmacokinetics/Pharmacodynamics Sensitivity Differences in mass (children, obese) Concomitant exposures Activity pattern Does not account for idiosyncracies</p>
<p>A = Animal to human Extrapolation from valid results of long-term studies on laboratory animals when results of studies of human exposure are not available or are inadequate. Intended to account for the uncertainty in extrapolating laboratory animal data to the case of average healthy humans.</p>	<p>Pharmacokinetics/Pharmacodynamics Relevance of laboratory animal model Species sensitivity</p>
<p>S = Subchronic to chronic Extrapolation from less than chronic exposure results on laboratory animals or humans when there are no useful long-term human data. Intended to account for the uncertainty in extrapolating from less than chronic NOAELs to chronic NOAELs.</p>	<p>Accumulation/Cumulative damage Pharmacokinetics/Pharmacodynamics Severity of effect Recovery Duration of study Consistency of effect with duration</p>
<p>L = LOAEL to NOAEL Derivation from a LOAEL instead of a NOAEL. Intended to account for the uncertainty in extrapolating from LOAELs to NOAELs.</p>	<p>Severity Pharmacokinetics/Pharmacodynamics Slope of dose-response curve Trend, consistency of effect Relationship of endpoints Functional vs. histopathological evidence Exposure uncertainties</p>
<p>D = Incomplete to complete data Extrapolation from valid results in laboratory animals when the data are "incomplete". Intended to account for the inability of any single laboratory animal study to adequately address all possible adverse outcomes in humans.</p>	<p>Quality of critical study Data gaps Power of critical study/supporting studies Exposure uncertainties</p>

uncertainty are present, and an RfC will not be derived. An RfC will also not be derived in the absence of data on the potential respiratory tract toxicity.

It should be noted that the basis for the UFs is empirical and has been derived from oral data (Dourson and Stara, 1983). In most cases, support of each UF was based on analysis of the ratios of effect levels. For example, analysis of the ratios of NOAELs from 90-day

studies compared to NOAELs from chronic studies was used to support a 10-fold factor to account for subchronic to chronic extrapolation. Because the different types of toxicity (portal-of-entry versus remote) may have different determinants underlying the exposure-dose-response continuum for which the default dosimetry adjustments only partially account, the appropriate magnitude for these UFs when using inhalation data is a topic of ongoing research at the EPA. Estimation procedures that are not sensitive to the spacing of exposure concentrations such as the benchmark and Bayesian approaches discussed in Appendix A are being explored instead of the previously used ratios approach for this research.

A UF is generally used to calculate RfCs with appropriate chronic human data, and is intended to account for intraspecies human variability to the adverse effects of a chemical (i.e., H in Tables 4-8 and 4-9). Empiric support for a 10-fold value for this UF is based on analyses of single-dose oral data (Weil, 1972; Dourson and Stara, 1983). Hattis et al. (1987) also suggest that a value of 10 is generally appropriate for this UF based on an analysis of human variability for key pharmacokinetic parameters.

For derivation of the RfC, the UF applied for interspecies extrapolation (i.e., A in Tables 4-8 and 4-9) is 3 due to the incorporation of dosimetric adjustments. If more rigorous adjustments can be made, an additional reduction of the UF would be warranted. The threefold factor represents the reduction of the usual 10-fold factor by half (i.e., 10^{-5}) since the default dosimetry accounts for variability in disposition (pharmacokinetics). The residual uncertainty is envisioned to address species differences in pharmacodynamics. A similar scheme was proposed by Renwick (1991), although the dosimetry adjustments in the RfC methods explicitly address disposition of particles and gases via inhalation. The empiric basis of this UF was originally based on oral data (Dourson and Stara, 1983). An analysis by Jarabek and Hasselblad (1991) showed that the deviation across species and chemicals for HEC estimates was reduced approximately 2-fold versus that using previous (Federal Register, 1980) derivation methods. The dosimetric adjustments have also been shown to be consistently less than those calculated with previous methods so that a reduction in the UF was further supported (Jarabek et al, 1989; Overton and Jarabek, 1989a,b).

An RfC based on a $\text{NOAEL}_{\text{HEC}}$ with satisfactory subchronic laboratory animal data would require a factor to address the uncertainty in extrapolating data from subchronic to chronic exposures (i.e., S in Table 4-8). Empirical evidence supporting the proposition that

subchronic toxicity data can be used with a 10-fold UF is again based on analyses of oral toxicity data (Dourson and Stara, 1983; Weil and McCollister, 1963; Weil et al., 1969). McNamara (1976) also demonstrated that a 10-fold factor applied to a subchronic NOEL would predict a chronic NOEL for 95% of the 122 compounds for which both chronic and subchronic data for the oral route of exposure were available. To the degree that route-specific and duration-specific data are not available, increased reliance on additional extrapolation assumptions and a larger UF is necessary. The lack of data with appropriate duration becomes of greater concern when either the chemical itself or its damage has the potential to accumulate. Conversely, if the effect is more dependent on concentration than duration, and progression of the lesion (either in incidence or severity) is not evident, a reduced UF may be considered.

Generally, a UF is applied to estimate RfCs using LOAELs if NOAELs are unavailable (i.e., L in Tables 4-8 and 4-9). This UF is employed to define an exposure level below the LOAEL expected to be in the range of a NOAEL. The empiric support for this UF was based on frequency analyses of LOAEL to NOAEL ratios for oral toxicity data after either subchronic or chronic exposures (Dourson and Stara, 1983; Weil and McCollister, 1963). In practice, this UF has varied and its value is chosen based on the severity of the adverse effect of the LOAEL. For example, if the LOAEL represents liver cell necrosis, a higher value is suggested for this UF than would be suggested if the LOAEL were based on fatty infiltration because the hypothesized NOAEL should be closer to the less severe LOAEL (Dourson and Stara, 1983).

Under some circumstances, a UF is applied when the data base is deficient in comprehensiveness; for example, if it lacks a two-generation reproductive study (i.e., D in Tables 4-8 and 4-9). The rationale for the minimum data base criteria provided in Section 4-1 can provide guidance on when a UF for lack of comprehensiveness is warranted. Dourson et al. (1992) have shown this to be an appropriate factor for oral data. The requirement for data in a second species is also supported by analyses that have shown lack of concordance for target tissues across species (Appelman and Feron, 1986; Heywood, 1981, 1983). The U.S. Food and Drug Administration has addressed the data base deficiencies issue with the use of a twofold safety factor. Therefore, in situations where a subchronic animal bioassay was available, but information in a second experimental species was lacking,

a 2,000-fold safety factor (i.e., $2_D \times 10_H \times 10_A \times 10_S$) was used to estimate an acceptable daily intake (Shibko, 1981). The influence that the requirement for portal of entry data and dosimetric adjustments used in the RfC methods may have on this UF has not yet been quantified.

There are certain circumstances specific to inhalation that may require changes in UFs. For example, the UF used when extrapolating from a subchronic to a chronic study is assumed to be adequate for oral studies in the great majority of cases. A UF of extrapolation of subchronic to chronic exposures for inhalation studies also should be adequate with certain exceptions. Possible exceptions include the following:

- Exposure to chemicals that are considered likely to induce hypersensitivity (see Section 2.1.2.3),
- Exposure to chemicals that are considered likely to induce very slowly developing ("smoldering") effects (e.g., beryllium), and
- Exposure to inhaled relatively insoluble particulate matter where the clearance rate may slow or stop when a threshold for clearance is reached. Therefore, after long-term exposure, lung loads can reach much higher levels than could reasonably be expected from lower level, chronic exposure conditions.

The appropriate UF for these situations should be decided on a case-by-case basis until more definitive guidelines are available.

4.3.9.2 Assignment of Confidence Levels

The selection of a $NOAEL_{[HEC]}$ or other appropriate measure of threshold response involves a process that incorporates scientific subjective judgment and statistical measures of significance. The qualitative and quantitative nature of this process results in an RfC associated with varying degrees of confidence that can be described as high, medium, and low.

A confidence level of high, medium, or low is assigned to the study used in the operational derivation, the overall data base, and to the RfC itself. Confidence ascribed to the RfC estimate is a function of both the confidence in the quality of the study and confidence in the completeness of the supporting data base together, with the data base

confidence taking precedence over that assigned to the study. High confidence in the RfC is an indication that the data base included investigation of a comprehensive array of noncancer toxicity endpoints, established from studies of chronic duration in various mammalian species, and that the study (or studies) established an unequivocal NOAEL_[HEC]. Therefore, a high confidence RfC is not likely to change as more data become available, with the exception of additional mechanistic data or sophisticated tests that may change the perspective of the evaluation. Low confidence in an RfC is usually applied to a derivation that is based on several extrapolations and indicates an estimate that may be especially vulnerable to change if additional data become available. If the individual study is of excellent quality, it most likely will receive a high confidence rating, although it may be subchronic in duration. Duration of the chosen study, as well as supporting studies and the spectrum of investigated endpoints (e.g., reproductive effects), are considered in the rating of confidence in the data base. Low confidence in the data base might be given to an excellent chosen subchronic study with few supporting studies and few endpoints examined. The confidence in the RfC then would reflect these two ratings by a rating of medium to low, indicating uncertainty (lack of confidence) and suggesting that further investigations may refine this number.

The level of confidence in a particular threshold value will be higher if it is derived from human data and supported by laboratory animal data. The parameters and factors involved in the evaluation of human data are described in Section 3.1.1. The degree of confidence in a particular laboratory animal study involves a number of parameters. These parameters include, but are not limited to, the following.

- Adequacy of study design
 - Is the route of exposure relevant to humans?
 - Were an appropriate number of animals and of both sexes used for determination of statistical significance?
 - Was the duration of exposure sufficient to allow results to be extrapolated to humans under different exposure conditions?
 - Were appropriate statistical techniques applied?
 - Were the analytical techniques sufficient to adequately measure the level of the test substance in the exposure protocol, including biological media?

- Is the animal species and strain appropriate as a surrogate for humans?
- Are the techniques for measurement of the biological endpoints scientifically sound and of sufficient sensitivity?
- To what degree may the biological endpoints be extrapolated (qualitatively or quantitatively) to humans?

- Demonstration of dose-response relationships
 - Were sufficient exposure levels used to demonstrate the highest NOAEL for the endpoint of concern?
 - Is the shape of the dose-response curve consistent with the known pharmacokinetics of the test substance?
 - Has the dose-response curve been replicated by or is it consistent with data from other laboratories and other laboratory animal species?

- Species differences
 - Are the metabolism and pharmacokinetics in the animal species similar to those for humans?
 - Is the species response consistent with that in other species?
 - Is the species from which the threshold value was derived the most sensitive species?

- Other factors
 - The number of biological endpoints evaluated and associated with dose-response relationships,
 - Sufficient description of exposure protocol, statistical tests, and results to make an evaluation, and
 - Condition of animals used in the study.

5. REFERENCES

- Adolph, E. F. (1949) Quantitative relations in the physiological constitutions of mammals. *Science* (Washington, DC) 109: 579-585.
- Aharonson, E. F.; Menkes, H.; Gurtner, G.; Swift, D. L.; Proctor, D. F. (1974) Effect of respiratory airflow rate on removal of soluble vapors by the nose. *J. Appl. Physiol.* 37: 654-657.
- Alarie, Y. (1981) Dose-response analysis in animal studies: prediction of human responses. *Environ. Health Perspect.* 42: 9-13.
- Alarie, Y. (1984) Establishing threshold limit values for airborne sensory irritants from an animal model and the mechanisms of action of sensory irritants. In: Esmen, N. A.; Mehlman, M. A., eds. *Occupational and industrial hygiene: concepts and methods*. Princeton, NJ: Princeton Scientific Publishers, Inc.; pp. 153-164. (*Advances in modern environmental toxicology*: v. 8).
- Albert, R. E.; Lippmann, M.; Peterson, H. T., Jr. (1971) The effects of cigarette smoking on the kinetics of bronchial clearance in humans and donkeys. In: Walton, W. H., ed. *Inhaled particles III, v. 1: proceedings of an international symposium organized by the British Occupational Hygiene Society; September 1970; London, United Kingdom. Surrey, United Kingdom: Unwin Brothers Limited;* pp. 165-182.
- Allen, B. C.; Fisher, J. W. (1993) Pharmacokinetic modeling of trichloroethylene and trichloroacetic acid in humans. *Risk Anal.* 13: 71-86.
- Amdur, M. O.; Mead, J. (1958) Mechanics of respiration in unanesthetized guinea pigs. *Am. J. Physiol.* 192: 364-368.
- American Conference of Governmental Industrial Hygienists. (1978) *Air sampling instruments: for evaluation of atmospheric contaminants*, 5th ed. Cincinnati, OH: American Conference of Governmental Industrial Hygienists.
- American Conference of Governmental Industrial Hygienists. (1986) *Documentation of the threshold limit values and biological exposure indices*. 5th ed. Cincinnati, OH: American Conference of Governmental Industrial Hygienists, Inc.; pp. 117, 313.
- American Industrial Health Council. (1989) *Presentation of risk assessments of carcinogens: report of an ad hoc study group on risk assessment presentation*. Washington, DC: American Industrial Health Council.
- American Industrial Health Council. (1992) *Improving risk characterization: summary of a workshop; September 1991; Washington, DC*. Washington, DC: American Industrial Health Council.
- American Thoracic Society. (1979) *ATS statement—Snowbird workshop on standardization of spirometry*. *Am. Rev. Respir. Dis.* 119: 831-838.
- American Thoracic Society. (1982) *Evaluation of impairment/disability secondary to respiratory disease*. *Am. Rev. Respir. Dis.* 126: 945-951.
- American Thoracic Society. (1985) *Guidelines as to what constitutes an adverse respiratory health effect, with special reference to epidemiologic studies of air pollution*. *Am. Rev. Respir. Dis.* 131: 666-668.

- American Thoracic Society. (1986) Evaluation of impairment/disability secondary to respiratory disorders. *Am. Rev. Respir. Dis.* 133: 1205-1209.
- American Thoracic Society. (1987a) Standardization of spirometry—1987 update. *Am. Rev. Respir. Dis.* 136: 1285-1298.
- American Thoracic Society. (1987b) Single breath carbon monoxide diffusing capacity (transfer factor): recommendations for a standard technique. *Am. Rev. Respir. Dis.* 136: 1299-1307.
- American Thoracic Society. (1991) Lung function testing: selection of reference values and interpretive strategies. *Am. Rev. Respir. Dis.* 144: 1202-1218.
- American Thoracic Society. (1993) Guidelines for the evaluation of impairment/disability in patients with asthma. *Am. Rev. Respir. Dis.* 147: 1056-1061.
- Andersen, M. E. (1981) A physiologically based toxicokinetic description of the metabolism of inhaled gases and vapors: analysis at steady state. *Toxicol. Appl. Pharmacol.* 60: 509-526.
- Andersen, M. E. (1987) Tissue dosimetry in risk assessment, or what's the problem here anyway? In: *Pharmacokinetics in risk assessment: drinking water and health*, v. 8. Washington, DC: National Academy Press; pp. 8-23.
- Andersen, M. E.; Clewell, H. J., III; Gargas, M. L.; Smith, F. A.; Reitz, R. H. (1987a) Physiologically based pharmacokinetics and the risk assessment process for methylene chloride. *Toxicol. Appl. Pharmacol.* 87: 185-205.
- Andersen, M. E.; MacNaughton, M. G.; Clewell, H. J., III; Paustenbach, D. J. (1987b) Adjusting exposure limits for long and short exposure periods using a physiological pharmacokinetic model. *Am. Ind. Hyg. Assoc. J.* 48: 335-343.
- Andersen, M. E.; Clewell, H. M., III; Gargas, M. L.; MacNaughton, M. G.; Reitz, R. H.; Nolan, R. J.; McKenna, M. J. (1991) Physiologically based pharmacokinetic modeling with dichloromethane, its metabolite, carbon monoxide, and blood carboxyhemoglobin in rats and humans. *Toxicol. Appl. Pharmacol.* 108: 14-27.
- Andersen, M. E.; Krishnan, K.; Conolly, R. B.; McClellan, R. O. (1992) Mechanistic toxicology research and biologically-based modeling: partners for improving quantitative risk assessments. *CIIT Activities* 12 (1): 1-7.
- Andre, S.; Metvier, H.; Lantenois, G.; Masse, R. (1987) Solubility of particles using cultured alveolar macrophages. Comparison with in vitro acellular model and data of in vivo solubility. Presented at: The design and interpretation of inhalation studies; March; Hannover, Federal Republic of Germany.
- Appelman, L. M.; Feron, V. J. (1986) Significance of the dog as 'second animal species' in toxicity testing for establishing the lowest 'no-toxic-effect level.' *J. Appl. Toxicol.* 6: 271-279.
- Aviado, D. M. (1978) Effects of fluorocarbons, chlorinated solvents, and inosine on the cardiopulmonary system. *Environ. Health Perspect.* 26: 207-215.
- Barnes, D. G.; Dourson, M. (1988) Reference dose (RfD): description and use in health risk assessments. *Regul. Toxicol. Pharmacol.* 8: 471-486.

- Baron, J.; Burke, J. P.; Guengerich, F. P.; Jakoby, W. B.; Voight, J. M. (1988) Sites for xenobiotic activation and detoxication within the respiratory tract: implications for chemically induced toxicity. *Toxicol. Appl. Pharmacol.* 93: 493-505.
- Barrow, C. S. (1989) Generation and characterization of gases and vapors. In: McClellan, R. O.; Henderson, R. F., eds. *Concepts in inhalation toxicology*. New York, NY: Hemisphere Publishing Corp.; pp. 63-84.
- Becklake, M. R.; Rodarte, J. R.; Kalica, A. R. (1988) NHLBI workshop summary: scientific issues in the assessment of respiratory impairment. *Am. Rev. Respir. Dis.* 137: 1505-1510.
- Berggren, M.; Dawson, J.; Moldeus, P. (1984) Glutathione biosynthesis in the isolated perfused rat lung: utilization of extracellular glutathione. *FEBS Lett.* 176: 189-192.
- Bigwood, E. J. (1973) The acceptable daily intake of food additives. *Crit. Rev. Toxicol.* 2: 41-93.
- Bird, R. B.; Stewart, W. E.; Lightfoot, E. N. (1960) *Transport phenomena*. New York, NY: John Wiley and Sons.
- Bliss, C. I. (1938) The determination of the dosage-mortality curve from small numbers. *Q. J. Pharm. Pharmacol.* 11: 192-216.
- Bliss, C. I. (1940) The relation between exposure time, concentration and toxicity in experiments on insecticides. *Ann. Entomol. Soc. Am.* 33: 721-766.
- Bliss, C. I.; James, A. T. (1966) Fitting the rectangular hyperbola. *Biometrics* 22: 573-602.
- Bogdanffy, M. S.; Taylor, M. L. (1993) Kinetics of nasal carboxylesterase-mediated metabolism of vinyl acetate. *Drug Metab. Dispos.* 21: 1107-1111.
- Bogdanffy, M. S.; Randall, H. W.; Morgan, K. T. (1986) Histochemical localization of aldehyde dehydrogenase in the respiratory tract of the Fischer-344 rat. *Toxicol. Appl. Pharmacol.* 82: 560-567.
- Bogdanffy, M. S.; Randall, H. W.; Morgan, K. T. (1987) Biochemical quantitation and histochemical localization of carboxylesterase in the nasal passages of the Fischer-344 rat and B6C3F1 mouse. *Toxicol. Appl. Pharmacol.* 88: 183-194.
- Bogdanffy, M. S.; Kee, C. R.; Hinchman, C. A.; Trela, B. A. (1991) Metabolism of dibasic esters by rat nasal mucosal carboxylesterase. *Drug Metab. Dispos.* 19: 124-129.
- Bohning, D. E.; Atkins, H. L.; Cohn, S. H. (1982) Long-term particle clearance in man: normal and impaired. In: Walton, W. H., ed. *Inhaled particles V: proceedings of an international symposium; September 1980; Cardiff, Wales*. *Ann. Occup. Hyg.* 26: 259-271.
- Bois, F. Y.; Zeise, L.; Tozer, T. N. (1990) Precision and sensitivity of pharmacokinetic models for cancer risk assessment: tetrachloroethylene in mice, rats, and humans. *Toxicol. Appl. Pharmacol.* 102: 300-315.
- Bond, J. A. (1989) Factors modifying the disposition of inhaled organic compounds. In: McClellan, R. O.; Henderson, R. F., eds. *Concepts in inhalation toxicology*. New York, NY: Hemisphere Publishing; pp. 249-298.
- Bos, P. M. J.; Zwart, A.; Reuzel, P. G. J.; Bragt, P. C. (1992) Evaluation of the sensory irritation test for the assessment of occupational health risk. *Crit. Rev. Toxicol.* 21: 423-450.
- Bowden, D. H. (1983) Cell turnover in the lung. *Am. Rev. Respir. Dis.* 128: S46-S48.

- Bowden, D. H. (1986) Macrophages, dust, and pulmonary diseases. *Exp. Lung Res.* 12: 89-107.
- Boyd, M. R. (1980) Biochemical mechanisms in chemical-induced lung injury: roles of metabolic activation. *Crit. Rev. Toxicol.* 7: 103-176.
- Boyd, M. R.; Statham, C. N. (1983) The effect of hepatic metabolism on the production and toxicity of reactive metabolites and extrahepatic organs. *Drug Metab. Rev.* 14: 35-47.
- Boxenbaum, H. (1982) Interspecies scaling, allometry, physiological time, and the ground plan of pharmacokinetics. *J. Pharmacokinet. Biopharm.* 10: 201-227.
- Brady, M. E. (1976) Gastrointestinal drug absorption in rats exposed to ^{60}Co γ -radiation [dissertation]. Pullman, WA: Washington State University. Available from: University Microfilms, Ann Arbor, MI; 76-27,715.
- Brain, J. D. (1986) Toxicological aspects of alterations of pulmonary macrophage function. *Ann. Rev. Pharmacol. Toxicol.* 26: 547-565.
- Brain, J. D.; Mensah, G. A. (1983) Comparative toxicology of the respiratory tract. *Am. Rev. Respir. Dis.* 128: S87-S90.
- Breyse, P. N.; Swift, D. L. (1990) Inhalability of large particles into the human nasal passage: in vivo studies in still air. *Aerosol Sci. Technol.* 13: 459-464.
- Briatico-Vangosa, G.; Braun, C. L. J.; Cookman, G.; Hofmann, T.; Kimber, I.; Loveless, S. E.; Morrow, T.; Pauluhn, J.; Sorensen, T.; Niessen, H. J. (1994) Respiratory allergy: hazard identification and risk assessment. *Fundam. Appl. Toxicol.* 23: 145-158.
- Brown, K. G.; Erdreich, L. S. (1989) Statistical uncertainty in the no-observed-adverse-effect level. *Fundam. Appl. Toxicol.* 13: 235-244.
- Bruce, M. C.; Bruce, E. N.; Leith, D. E.; Murphy, S. D. (1979) Diethyl maleate and/or ozone (10 ppm) reduce ventilation by 60-80% in awake mice. *Physiologist* 22: 16.
- Buckley, L. A.; Jiang, X. Z.; James, R. A.; Morgan, K. T.; Barrow, C. S. (1984) Respiratory tract lesions induced by sensory irritants at the RD50 concentration. *Toxicol. Appl. Pharmacol.* 74: 417-429.
- Bull, R. J. (1989) Decision model for the development of biomarkers of exposure. Las Vegas, NV: U.S. Environmental Protection Agency, Environmental Monitoring Systems Laboratory; EPA report no. EPA/600/X-89/163.
- Burger, G. T.; Renne, R. A.; Sagartz, J. W.; Ayres, P. H.; Coggins, C. R. E.; Mosberg, A. T.; Hayes, A. W. (1989) Histologic changes in the respiratory tract induced by inhalation of xenobiotics: physiologic adaptation or toxicity? *Toxicol. Appl. Pharmacol.* 101: 521-542.
- Burri, P. H. (1985) Morphology and respiratory function of the alveolar unit. In: *Immunopathology and immunopharmacology of the lung: advanced course at the Alessandro Volta Center*; June 1984; Villa Olmo, Como, Italy. *Int. Arch. Allergy Appl. Immunol.* 76(suppl. 1): 2-12.
- Calabrese, E. J. (1978) *Pollutants and high-risk groups: the biological basis of increased human susceptibility to environmental and occupational pollutants*. New York, NY: John Wiley and Sons.
- Calabrese, E. J. (1981) *Nutrition and environmental health: the influence of nutritional status on pollutant toxicity and carcinogenicity*. New York, NY: John Wiley and Sons.

- Calabrese, E. J. (1983) Principles of animal extrapolation. New York, NY: John Wiley & Sons, Inc.
- Calabrese, E. J. (1985) Uncertainty factors and interindividual variation. *Regul. Toxicol. Pharmacol.* 5: 190-196.
- Casanova-Schmitz, M.; Starr, T. B.; Heck, H. d'A. (1984) Differentiation between metabolic incorporation and covalent binding in the labeling of macro-molecules in the rat nasal mucosa and bone marrow by inhaled ¹⁴C- and ³H-formaldehyde. *Toxicol. Appl. Pharmacol.* 76: 26-44.
- Casanova, M.; Morgan, K. T.; Steinhagen, W. H.; Everitt, J. I.; Popp, J. A.; Heck, H. d'A. (1991) Covalent binding of inhaled formaldehyde to DNA in the respiratory tract of rhesus monkeys: pharmacokinetics, rat-to-monkey interspecies scaling, and extrapolation to man. *Fundam. Appl. Toxicol.* 17: 409-428.
- Casarett, L. J. (1975) Toxicology of the respiratory system. In: Casarett, L. J.; Doull, J., eds. *Toxicology: the basic science of poisons*. New York, NY: MacMillan Publishing Co., Inc.; pp. 201-224.
- Castleman, B. I.; Ziem, G. E. (1988) Corporate influence on threshold limit values. *Am. J. Ind. Med.* 13: 531-559.
- Chan, T. L.; Lippmann, M. (1980) Experimental measurements and empirical modelling of the regional deposition of inhaled particles in humans. *Am. Ind. Hyg. Assoc. J.* 41: 399-409.
- Chan, T. L.; Lee, P. S.; Hering, W. E. (1984) Pulmonary retention of inhaled diesel particles after prolonged exposures to diesel exhaust. *Fundam. Appl. Toxicol.* 4: 624-631.
- Chan-Yeung, M. (1987) Evaluation of impairment/disability in patients with occupational asthma. *Am. Rev. Respir. Dis.* 135: 950-951.
- Chan-Yeung, M.; Lam, S. (1986) Occupational asthma. *Am. Rev. Respir. Dis.* 133: 686-703.
- Chandra, S. V.; Shukla, G. S.; Srivastava, R. S.; Singh, H.; Gupta, V. P. (1981) An exploratory study of manganese exposure to welders. *Clin. Toxicol.* 18: 407-416.
- Chang, J. C. F.; Gross, E. A.; Swenberg, J. A.; Barrow, C. S. (1983) Nasal cavity deposition, histopathology, and cell proliferation after single or repeated formaldehyde exposures in B6C3F1 mice and F-344 rats. *Toxicol. Appl. Pharmacol.* 68: 161-176.
- Checkoway, H.; Rice, C. H. (1992) Time-weighted averages, peaks, and other indices of exposure in occupational epidemiology. *Am. J. Ind. Med.* 21: 25-33.
- Chemical Manufacturers Association's Epidemiology Task Group. (1991) Guidelines for good epidemiology practices for occupational and environmental epidemiological research. Washington, DC: Chemical Manufacturers Association.
- Cheng, Y.-S.; Moss, O. R. (1989) Inhalation exposure systems. In: McClellan, R. O.; Henderson, R. F., eds. *Concepts in inhalation toxicology*. New York, NY: Hemisphere Publishing Corp.; pp. 19-62.
- Cheng, Y. S.; Yamada, Y.; Yeh, H. C.; Swift, D. L. (1988) Diffusional deposition of ultrafine aerosol in a human nasal cast. *J. Aerosol. Sci.* 19: 741-751.
- Cheng, Y. S.; Hansen, G. K.; Su, Y. F.; Yeh, H. C.; Morgan, K. T. (1990) Deposition of ultrafine aerosols in rat nasal molds. *Toxicol. Appl. Pharmacol.* 106: 222-233.
- Clausen, J. L., ed. (1982) Pulmonary function testing guidelines and controversies: equipment, methods, and normal values. Orlando, FL: Grune and Stratton, Inc.

- Clegg, D. J. (1979) Toxicological basis of the ADI—present and future considerations. In: Frehse, H.; Geissbuhler, H., eds. Pesticide residues: a contribution to their interpretation, relevance and legislation. New York, NY: Pergamon Press; pp. 74-77.
- Cleveland, W. S. (1985) The elements of graphing data. Pacific Grove, CA: Wadsworth and Brooks.
- Code of Federal Regulations. (1991a) National primary and secondary ambient air quality standards. C. F. R. 40: §50.
- Code of Federal Regulations. (1991b) Good laboratory practice standards [FIFRA]. C. F. R. 40: §160.
- Code of Federal Regulations. (1991d) Health effects testing guidelines. C. F. R. 40: §798.
- Code of Federal Regulations. (1991c) Good laboratory practice standards [TSCA]. C. F. R. 40: §792.
- Conolly, R. B. (1990) Biologically-based models for toxic effects: tools for hypothesis testing and improving health risk assessments. CIIT Activities 10: 1-8.
- Corley, R. A.; Reitz, R. H. (1990) Dose-route extrapolations in quantitative toxicology: physiologically based pharmacokinetics and pharmacodynamics of chloroform. In: Gerrity, T. R.; Henry, C. J., eds. Principles of route-to-route extrapolation for risk assessment, proceedings of the workshops; March and July; Hilton Head, SC and Durham, NC. New York, NY: Elsevier Science Publishing Co., Inc.; pp. 195-216.
- Costa, D. L.; Tepper, J. S. (1988) Approaches to lung function assessment in small mammals. In: Gardner, D.; Crapo, J.; Massaro, E., eds. Target organ toxicology series: toxicology of the lung. New York, NY: Raven Press, Ltd.; pp. 147-174.
- Costa, D. L.; Tepper, J. S.; Raub, J. A. (1992) Interpretations and limitations of pulmonary function testing in small laboratory animals. In: Parent, R. A., ed. Comparative biology of the normal lung: v. 1, treatise on pulmonary toxicology. Boca Raton, FL: CRC Press; pp. 367-399.
- Crapo, J. D. (1987) Personal communication to A. Jarabek, Environmental Criteria and Assessment Office, Cincinnati, OH, concerning interspecies cell population data and the confirmation of rudimentary respiratory bronchioles by 3-D reconstruction in the rat acinus. Durham, NC: Duke University.
- Crapo, R. O.; Morris, A. H.; Gardner, R. M. (1981) Reference spirometric values using techniques and equipment that meet ATS recommendations. Am. Rev. Respir. Dis. 123: 659-664.
- Crapo, J. D.; Young, S. L.; Fram, E. K.; Pinkerton, K. E.; Barry, B. E.; Crapo, R. O. (1983) Morphometric characteristics of cells in the alveolar region of mammalian lungs. Am. Rev. Respir. Dis. 128: S42-S46.
- Cropp, G. J. A.; Bernstein, I. L.; Boushey, H. A., Jr.; Hyde, R. W.; Rosenthal, R. R.; Spector, S. L.; Townley, R. G. (1980) Guidelines for bronchial inhalation challenges with pharmacologic and antigenic agents. ATS News (Spring): 11-19.
- Crump, K. S. (1984) A new method for determining allowable daily intakes. Fundam. Appl. Toxicol. 4: 854-871.
- Crump, K. S. (1986) [Letter to the editor]. Fundam. Appl. Toxicol. 6: 183-184.
- Cullen, M. R. (1989) The role of clinical investigations in biological markers research. Environ. Res. 50: 1-10.
- Dahl, A. R. (1990) Dose concepts for inhaled vapors and gases. Toxicol. Appl. Pharmacol. 103: 185-197.

- Dahl, A. R.; Miller, S. C.; Petridou-Fischer, J. (1987) Carboxylesterases in the respiratory tracts of rabbits, rats and Syrian hamsters. *Toxicol. Lett.* 36: 129-136.
- Dahl, A. R.; Bond, J. A.; Petridou-Fischer, J.; Sabourin, P. J.; Whaley, S. J. (1988) Effects of the respiratory tract on inhaled materials. *Toxicol. Appl. Pharmacol.* 93: 484-492.
- Dahl, A. R.; Schlesinger, R. B.; Heck, H. D' A.; Medinsky, M. A.; Lucier, G. W. (1991a) Comparative dosimetry of inhaled materials: differences among animal species and extrapolation to man. *Fundam. Appl. Toxicol.* 16: 1-13.
- Dahl, A. R.; Snipes, M. B.; Gerde, P. (1991b) Sites for uptake of inhaled vapors in beagle dogs. *Toxicol. Appl. Pharmacol.* 109: 263-275.
- Davis, J. M.; Svendsgaard, D. J. (1990) U-shaped dose-response curves: their occurrence and implications for risk assessment. *J. Toxicol. Environ. Health* 30: 71-83.
- Dayan, J.; Levenspiel, O. (1969) Dispersion in smooth pipes with adsorbing walls. *Ind. Eng. Chem. Fundam.* 8: 840-842.
- De Rosa, C. T.; Stara, J. F.; Durkin, P. R. (1985) Ranking chemicals based on chronic toxicity data. *Toxicol. Ind. Health* 1: 177-191.
- Dearman, R. J.; Spence, L. M.; Kimber, I. (1992) Characterization of murine immune responses to allergenic diisocyanates. *Toxicol. Appl. Pharmacol.* 112: 190-197.
- Dedrick, R. L. (1973) Animal scale-up. *J. Pharmacokinet. Biopharm.* 1: 435-461.
- Dedrick, R. L.; Bischoff, K. B. (1980) Species similarities in pharmacokinetics. *Fed. Proc.* 39: 54-59.
- DeSesso, J. M. (1993) The relevance to humans of animal models for inhalation studies of cancer in the nose and upper airways. *Qual. Assur. (San Diego)* 2: 213-231.
- Domin, B. A.; Philpot, R. M. (1986) The effect of substrate on the expression of activity catalyzed by cytochrome P-450: metabolism mediated by rabbit isozyme 6 in pulmonary microsomal and reconstituted monooxygenase systems. *Arch. Biochem. Biophys.* 246: 128-142.
- Dorato, M. A.; Carlson, K. H.; Copple, D. L. (1983) Pulmonary mechanics in conscious Fischer 344 rats: multiple evaluations using nonsurgical techniques. *Toxicol. Appl. Pharmacol.* 68: 344-353.
- Doull, J.; Klaassen, C. D.; Amdur, M. O., eds. (1980) *Casarett and Doull's toxicology: the basic science of poisons*. 2nd ed. New York, NY: MacMillan Publishing Co., Inc.
- Dourson, M. L. (1986) New approaches in the derivation of acceptable daily intake (ADI). *Comments Toxicol.* 1: 35-48.
- Dourson, M. L.; Stara, J. F. (1983) Regulatory history and experimental support of uncertainty (safety) factors. *Regul. Toxicol. Pharmacol.* 3: 224-238.
- Dourson, M. L.; Hertzberg, R. C.; Hartung, R.; Blackburn, K. (1985) Novel methods for the estimation of acceptable daily intake. *Toxicol. Ind. Health* 1: 23-33.
- Dourson, M. L.; Hertzberg, R. C.; Stara, J. F. (1986) [Letter to the editor]. *Fundam. Appl. Toxicol.* 6: 182-183.

- Dourson, M. L.; Swartout, J. C.; Stara, J. F. (1987) Excursions above the acceptable daily intake. *Toxicologist* 7: 184.
- Dourson, M. L.; Knauf, L. A.; Swartout, J. C. (1992) On reference dose (RfD) and its underlying toxicity data base. *Toxicol. Ind. Health* 8: 171-189.
- Droz, P. O. (1985) The use of simulation models for setting BEIs for organic solvents. In: International symposium on occupational exposure limits. Cincinnati, OH: American Conference of Governmental Industrial Hygienists; pp. 339-350. (*Annals of the American Conference of Governmental Industrial Hygienists*: v. 12).
- Dunnick, J. K.; Graham, D. G.; Yang, R. S. H.; Haber, S. B.; Brown, H. R. (1989) Thirteen-week toxicity study of *n*-hexane in B6C3F₁ mice after inhalation exposure. *Toxicology* 57: 163-172.
- Eddy, D. M.; Hasselblad, V.; Shachter, R. (1992) Meta-analysis by the confidence profile method: the statistical synthesis of evidence. Boston, MA: Academic Press, Inc.
- Eisner, A. D.; Graham, R. C.; Martonen, T. B. (1990) Coupled mass and energy transport phenomena in aerosol/vapor-laden gasses—I. Theory of the hygroscopic aerosol effects on temperature and relative humidity patterns of inspired air. *J. Aerosol. Sci.* 21: 833-848.
- Emmett, P. C.; Aitken, R. J.; Hannan, W. J. (1982) Measurements of the total and regional deposition of inhaled particles in the human respiratory tract. *J. Aerosol Sci.* 13: 549-560.
- Environ Corporation. (1985) Background document on the development and use of reference doses. Part I: data needs and apportionment. Part II: considerations related to the development of protocols for toxicity studies [draft]. Washington, DC: U.S. Environmental Protection Agency, Office of Solid Waste; EPA report no. EPA/530/SW-86/048. Available from: NTIS, Springfield, VA; PB87-107173/XAB.
- Epler, G. R.; Saber, F. A.; Gaensler, E. A. (1980) Determination of severe impairment (disability) in interstitial lung disease. *Am. Rev. Respir. Dis.* 121: 647-659.
- Erdreich, L. S. (1988) Combining animal and human data: resolving conflicts, summarizing the evidence. In: Gordis, L., ed. *Epidemiology and health risk assessment*. New York, NY: Oxford University Press; pp. 197-207.
- Erdreich, L. S.; Burnett, C. (1985) Improving the use of epidemiologic data in health risk assessment. *Toxicol. Ind. Health* 1: 65-81.
- Erdreich, L. S.; Sonich Mullin, C. (1984) Hypersusceptible subgroups of the population in multichemical risk assessment. In: Stara, J. F.; Erdreich, L. S., eds. *Approaches to risk assessment for multiple chemical exposures*. Washington, DC: U.S. Environmental Protection Agency, Office of Health and Environmental Assessment, Environmental Criteria and Assessment Office; EPA report no. EPA-600/9-84-008; pp. 189-218. Available from: NTIS, Springfield, VA; PB84-182369.
- Fabro, S.; Shull, G.; Brown, N. A. (1982) The relative teratogenic index and teratogenic potency: proposed components of developmental toxicity risk assessment. *Teratog. Carcinog. Mutagen.* 2: 61-76.
- Farrar, D.; Allen, B.; Crump, K.; Shipp, A. (1989) Evaluation of uncertainty in input parameters to pharmacokinetic models and the resulting uncertainty in output. *Toxicol. Lett.* 49: 371-385.
- Federal Register. (1980) Guidelines and methodology used in the preparation of health effects assessment chapters of the consent decree water criteria documents. *F. R.* (November 28) 45: 49347-49357.

- Federal Register. (1988a) Intent to review guidelines for carcinogen risk assessment. F. R. (August 26) 53: 32656-32658.
- Federal Register. (1988b) Proposed guidelines for assessing female reproductive risk. F. R. (June 30) 53: 24834-24847.
- Federal Register. (1988c) Proposed guidelines for assessing male reproductive risk. F. R. (June 30) 53: 24850-24869.
- Federal Register. (1991) Guidelines for developmental toxicity risk assessment. F. R. (December 5) 56: 63798-63826.
- Federal Register. (1992a) Guidelines for exposure assessment. F. R. (May 29) 57: 22887-22938.
- Federal Register. (1992b) Draft report: a cross-species scaling factor for carcinogen risk assessment based on equivalence of mg/kg^{3/4}/day. F. R. (June 5) 57: 24152-24173.
- Federspiel, W. J.; Fredberg, J. J. (1988) Axial dispersion in respiratory bronchioles and alveolar ducts. *J. Appl. Physiol.* 64: 2614-2621.
- Ferris, B. G. (1978) Epidemiology standardization project: II. recommended respiratory disease questionnaires for use with adults and children in epidemiological research. *Am. Rev. Respir. Dis.* 118(suppl.): 7-53.
- Ferron, G. A.; Hornik, S. (1984) Influence of different humidity profiles on the deposition probability of soluble particles in the human lung. *J. Aerosol. Sci.* 15: 209-211.
- Finney, D. J. (1978) *Statistical method in biological assay*. London, United Kingdom: Griffin.
- Fiserova-Bergerova, V., ed. (1983) *Modeling of inhalation exposure to vapors: uptake, distribution, and elimination: volumes I and II*. Boca Raton, FL: CRC Press, Inc.
- Fiserova-Bergerova, V. (1990) Application of toxicokinetic models to establish biological exposure indicators. *Ann. Occup. Hyg.* 34: 639-651.
- Fiserova-Bergerova, V.; Diaz, M. L. (1986) Determination and prediction of tissue-gas partition coefficients. *Int. Arch. Occup. Environ. Health* 58: 75-87.
- Fiserova-Bergerova, V.; Vlach, J.; Cassady, J. C. (1980) Predictable "individual differences" in uptake and excretion of gases and lipid soluble vapours simulation study. *Br. J. Ind. Med.* 37: 42-49.
- Fiserova-Bergerova, V.; Tichy, M.; Di Carlo, F. J. (1984) Effects of biosolubility on pulmonary uptake and disposition of gases and vapors of lipophilic chemicals. *Drug Metab. Rev.* 15: 1033-1070.
- Fisher, J. W.; Allen, B. C. (1993) Evaluating the risk of liver cancer in humans exposed to trichloroethylene using physiological models. *Risk Anal.* 13: 87-95.
- Folinsbee, L. J. (1988) Human clinical inhalation exposures experimental design, methodology, and physiological responses. In: Gardner, D. E.; Crapo, J. D.; Massaro, E. J., eds. *Toxicology of the lung*. New York, NY: Raven Press; pp. 175-199.
- Fox, A. J.; Collier, P. F. (1976) Low mortality rates in industrial cohort studies due to selection for work and survival in the industry. *Br. J. Prev. Soc. Med.* 30: 225-230.

- Friberg, L.; Nordberg, G. F.; Vouk, V. B., eds. (1979) Handbook on the toxicology of metals. Amsterdam, The Netherlands: Elsevier/North-Holland Biomedical Press.
- Gann, P. (1986) Use and misuse of existing data bases in environmental epidemiology: the case of air pollution. In: Kopfler, F. C.; Craun, G. F., eds. Environmental epidemiology. Chelsea, MI: Lewis Publishers, Inc.
- Gardner, D. E.; Kennedy, G. L., Jr. (1993) Methodologies and technology for animal inhalation toxicology studies. In: Contributions to the scientific literature from the Haskell Laboratory for Toxicology and Industrial Medicine. Newark, DE: E. I. duPont de Nemours and Co.; pp. 295-324.
- Gardner, D. E.; Miller, F. J.; Blommer, E. J.; Coffin, D. L. (1979) Influence of exposure mode on the toxicity of NO₂. Environ. Health Perspect. 30: 23-29.
- Gardner, R. M.; Clausen, J. L.; Epler, G.; Hankinson, J. L.; Permutt, S.; Plummer, A. L. (1986a) Pulmonary function laboratory personnel qualifications. Am. Rev. Respir. Dis. 134: 623-624.
- Gardner, R. M.; Clausen, J. L.; Crapo, R. O.; Epler, G. R.; Hankinson, J. L.; Johnson, R. L.; Plummer, A. L. (1986b) Quality assurance in pulmonary function laboratories. Am. Rev. Respir. Dis. 134: 625-627.
- Gardner, R. M.; Clausen, J. L.; Cotton, D. J.; Crapo, R. O.; Epler, G. R.; Hankinson, J. L.; Johnson, R. L. (1986c) Computer guidelines for pulmonary laboratories. Am. Rev. Respir. Dis. 134: 628-629.
- Gargas, M. L.; Burgess, R. J.; Voisard, D. E.; Cason, G. H.; Andersen, M. E. (1989) Partition coefficients of low-molecular-weight volatile chemicals in various liquids and tissues. Toxicol. Appl. Pharmacol. 98: 87-99.
- Gaylor, D. W. (1983) The use of safety factors for controlling risk. J. Toxicol. Environ. Health 11: 329-336.
- Gaylor, D. W. (1985) The question of the existence of thresholds: extrapolation from high to low dose. In: Flamm, W. G.; Lorentzen, R. J., eds. Mechanisms in toxicology of chemical carcinogens and mutagens. Princeton, NJ: Princeton Scientific Publishing Co., Inc.; pp. 249-260. (Advances in modern environmental toxicology: v. 12).
- Gaylor, D. W.; Kodell, R. L. (1980) Linear interpolation algorithm for low dose risk assessment of toxic substances. J. Environ. Pathol. Toxicol. 4: 305-312.
- Geelhaar, A.; Weibel, E. R. (1971) Morphometric estimation of pulmonary diffusion capacity: III. the effect of increased oxygen consumption in Japanese Waltzing mice. Respir. Physiol. 11: 354-366.
- Gehr, P.; Mwangi, D. K.; Ammann, A.; Maloiy, G. M. O.; Taylor, C. R.; Weibel, E. R. (1981) Design of the mammalian respiratory system. V. Scaling morphometric pulmonary diffusing capacity to body mass: wild and domestic animals. Respir. Physiol. 44: 61-86.
- Gerde, P.; Dahl, A. R. (1991) A model for the uptake of inhaled vapors in the nose of the dog during cyclic breathing. Toxicol. Appl. Pharmacol. 109: 276-288.
- Gerde, P.; Medinsky, M. A.; Bond, J. A. (1991) Particle-associated polycyclic aromatic hydrocarbons—a reappraisal of their possible role in pulmonary carcinogenesis. Toxicol. Appl. Pharmacol. 108: 1-13.
- Gerrity, T. R.; Henry, C. J., eds. (1990) Summary report of the workshops on principles of route-to-route extrapolation for risk assessment. In: Principles of route-to-route extrapolation for risk assessment, proceedings of the workshops; March and July; Hilton Head, SC and Durham, NC. New York, NY: Elsevier Science Publishing Co., Inc.; pp. 1-12.

- Goldstein, B. D. (1983) Toxic substances in the atmospheric environment: a critical review. *J. Air Pollut. Control Assoc.* 33: 454-467.
- Graham, J. A.; Miller, F. J.; Davies, D. W.; Hiteshew, M. E.; Walsh, L. C., III. (1985) Inhalation studies of Mt. St. Helens volcanic ash in animals: I. introduction and exposure system. *Environ. Res.* 37: 61-71.
- Graham, J. A.; Gardner, D. E.; Blommer, E. J.; House, D. E.; Ménache, M. G.; Miller, F. J. (1987) Influence of exposure patterns of nitrogen dioxide and modifications by ozone on susceptibility to bacterial infectious disease in mice. *J. Toxicol. Environ. Health* 21: 113-125.
- Gram, T. E.; Okine, L. K.; Gram, R. A. (1986) The metabolism of xenobiotics by certain extrahepatic organs and its relation to toxicity. *Ann. Rev. Pharmacol. Toxicol.* 26: 259-291.
- Griffis, L. C.; Wolff, R. K.; Beethe, R. L.; Hobbs, C. H.; McClellan, R. O. (1981) Evaluation of a multitiered inhalation exposure chamber. *Fundam. Appl. Toxicol.* 1: 8-12.
- Griffis, L. C.; Wolff, R. K.; Henderson, R. F.; Griffith, W. C.; Mokler, B. V.; McClellan, R. O. (1983) Clearance of diesel soot particles from rat lung after a subchronic diesel exhaust exposure. *Fundam. Appl. Toxicol.* 3: 99-103.
- Griffith, J.; Duncan, R. C.; Hulka, B. S. (1989) Biochemical and biological markers: implications for epidemiologic studies. *Arch. Environ. Health* 44: 375-381.
- Gross, E. A.; Morgan, K. T. (1992) Architecture of nasal passages and larynx. In: Parent, R. A., ed. *Comparative biology of the normal lung: v. I, treatise on pulmonary toxicology*. Boca Raton, FL: CRC Press, Inc.; pp. 7-25.
- Gross, E. A.; Swenberg, J. A.; Fields, S.; Popp, J. A. (1982) Comparative morphometry of the nasal cavity in rats and mice. *J. Anat.* 135: 83-88.
- Guilmette, R. A.; Wicks, J. D.; Wolff, R. K. (1989) Morphometry of human nasal airways *in vivo* using magnetic resonance imaging. *J. Aerosol. Med.* 2: 365-377.
- Guth, D. J.; Jarabek, A. M.; Wymer, L.; Hertzberg, R. C. (1991) Evaluation of risk assessment methods for short-term inhalation exposure. Presented at: 84th annual meeting and exhibition; June. Pittsburgh, PA: Air and Waste Management Association; paper no. 91-173.2.
- Guth, D. J.; Hertzberg, R. C.; Jarabek, A. M. (1993) Exposure-response analysis: modeling severity against concentration and duration. In: Beck, B. D.; Connolly, R. B.; Dourson, M. L.; Guth, D.; Hattis, D.; Kimmel, C.; Lewis, S. C. *Improvements in quantitative noncancer risk assessment: symposium overview*, Society of Toxicology meeting; February 1992; Seattle, WA. *Fundam. Appl. Toxicol.* 20: 9-12.
- Habicht, F. H., II. (1992) Guidance on risk characterization for risk managers and risk assessors [memorandum to EPA assistant administrators and regional administrators]. Washington, DC: U.S. Environmental Protection Agency, Office of the Administrator; February 26.
- Hackney, J. D.; Linn, W. S. (1979) Koch's postulates updated: a potentially useful application to laboratory research and policy analysis in environmental toxicology. *Am. Rev. Respir. Dis.* 119: 849-852.
- Hackney, J. D.; Linn, W. S. (1983) Controlled clinical studies of air pollutant exposure: evaluating scientific information in relation to air quality standards. *Environ. Health Perspect.* 52: 187-191.
- Hahn, I.; Scherer, P. W.; Mozell, M. M. (1993) Velocity profiles measured for airflow through a large-scale model of the human nasal cavity. *J. Appl. Physiol.* 75: 2273-2287.

- Hakkinen, P. J.; Witschi, H. P. (1985) Animal models. In: Witschi, H. P.; Brain, J. D., eds. Toxicology of inhaled materials: general principles of inhalation toxicology. New York, NY: Springer-Verlag; pp. 95-114. (Handbook of experimental pharmacology: v. 75).
- Hanna, L. M.; Scherer, P. W. (1986) Measurement of local mass transfer coefficients in a cast model of the human upper respiratory tract. *J. Biomech. Eng.* 108: 12-18.
- Hanna, L. M.; Frank, R.; Scherer, P. W. (1989) Absorption of soluble gases and vapors in the respiratory system. In: Chang, H. K.; Paiva, M., eds. Respiratory physiology: an analytical approach. New York, NY: Marcel Dekker, Inc.; pp. 277-316. (Lenfant, C., ed. Lung biology in health and disease: v. 40).
- Harkema, J. R. (1991) Comparative aspects of nasal airway anatomy: relevance to inhalation toxicology. *Toxicol. Pathol.* 19: 321-336.
- Hartung, R. (1986) Ranking the severity of toxic effects. In: Hemphill, D. D., ed. Trace substances in environmental health—XX: [proceedings of University of Missouri's 20th annual conference]; June; Columbia, MO. Columbia, MO: University of Missouri-Columbia; pp. 204-211.
- Hasselblad, V.; Jarabek, A. M. (1994) Dose-response analysis of toxic chemicals. In: Berry, D. A.; Stangl, D. K., eds. Bayesian biostatistics. New York, NY: Marcel Dekker: in press.
- Hatch, T.; Choate, S. P. (1929) Statistical description of the size properties of non-uniform particulate substances. *J. Franklin Inst.* 207: 369-387.
- Hatch, T. F.; Gross, P. (1964) Pulmonary deposition and retention of inhaled aerosols. New York, NY: Academic Press, Inc.
- Hattis, D. B. (1986) The promise of molecular epidemiology for quantitative risk assessment. *Risk Anal.* 6: 181-193.
- Hattis, D. (1991) Use of biological markers and pharmacokinetics in human health risk assessment. *Environ. Health Perspect.* 90: 229-238.
- Hattis, D.; Erdreich, L.; Ballew, M. (1987) Human variability in susceptibility to toxic chemicals—a preliminary analysis of pharmacokinetic data from normal volunteers. *Risk Anal.* 7: 415-426.
- Hattis, D.; White, P.; Marmorstein, L.; Koch, P. (1990) Uncertainties in pharmacokinetic modeling for perchloroethylene. I. Comparison of model structure, parameters, and predictions for low-dose metabolism rates for models derived by different authors. *Risk Anal.* 10: 449-458.
- Hertzberg, R. C. (1989) Fitting a model to categorical response data with application to species extrapolation of toxicity. In: Proceedings of the 26th Hanford life sciences symposium, "Modeling for scaling to man"; October 1987. Richland, WA: Battelle Pacific Northwest Laboratories. *Health Phys.* 57 (suppl.): 405-409.
- Heyder, J.; Rudolf, G. (1977) Deposition of aerosol particles in the human nose. In: Walton, W. H., ed. Inhaled particles IV, part 1: proceedings of an international symposium organized by the British Occupational Hygiene Society; September 1975; Edinburgh, United Kingdom. Pergamon Press; pp. 107-126.
- Heyder, J.; Armbruster, L.; Gebhart, J.; Grein, E.; Stahlhofen, W. (1975) Total deposition of aerosol particles in the human respiratory tract for nose and mouth breathing. *J. Aerosol Sci.* 6: 311-328.
- Heyder, J.; Gebhart, J.; Rudolf, G.; Schiller, C. F.; Stahlhofen, W. (1986) Deposition of particles in the human respiratory tract in the size range 0.005-15 μm . *J. Aerosol Sci.* 17: 811-825.

- Heywood, R. (1981) Target organ toxicity. *Toxicol. Lett.* 8: 349-358.
- Heywood, R. (1983) Target organ toxicity II. *Toxicol. Lett.* 18: 83-88.
- Hinds, W. C. (1982) *Aerosol technology*. New York, NY: John Wiley and Sons.
- Hofmann, W. (1982) The effect of polydispersiveness of natural radioactive aerosols on tracheobronchial deposition. *Radiat. Prot. Dosim.* 3: 97-101.
- Hofmann, W.; Koblinger, L. (1989) The effect of polydispersity of radioactive aerosols on the activity distribution in the human lung. *J. Aerosol Sci.* 20: 1313-1316.
- Holland, W. W.; Bennett, A. E.; Cameron, I. R.; Florey, C. du V.; Leeder, S. R.; Schilling, R. S. F.; Swan, A. V.; Waller, R. E. (1979) Health effects of particulate pollution: reappraising the evidence. *Am. J. Epidemiol.* 110: 525-659.
- Huang, Y.; Chang, L.; Miller, F.; Graham, J.; Ospital, J.; Crapo, J. (1988) Lung injury caused by ambient levels of oxidant air pollutants: extrapolation from animals to man. *J. Aerosol Med.* 1: 180-183.
- Hulka, B. S.; Wilcosky, T. (1988) Biological markers in epidemiologic research. *Arch. Environ. Health* 43: 83-89.
- IRIS, Integrated Risk Information System [database]. (1990) [Printout of reference concentration for chronic inhalation exposure (RfC) for n-hexane as verified 4/19/90]. Cincinnati, OH: U.S. Environmental Protection Agency, Office of Health and Environmental Assessment, Environmental Criteria and Assessment Office. Available online from: TOXNET, National Library of Medicine, Rockville, MD.
- IRIS, Integrated Risk Information System [database]. (1992) [Printout of reference concentration for chronic inhalation exposure (RfC) for diesel engine emissions as verified 6/25/92]. Cincinnati, OH: U.S. Environmental Protection Agency, Office of Health and Environmental Assessment, Environmental Criteria and Assessment Office. Available online from: TOXNET, National Library of Medicine, Rockville, MD.
- Interagency Regulatory Liaison Group. (1981) Guidelines for documentation of epidemiological studies. *Am. J. Epidemiol.* 114: 609-613.
- International Commission on Radiological Protection. (1993) Gases and vapours. In: *Human respiratory tract model for radiological protection: a report of Committee 2 of the International Commission on Radiological Protection*. Sutton, Surrey, United Kingdom: International Commission on Radiological Protection; pp. 57-66; April 15.
- International Standards Organization. (1981) Report of ad hoc working group to technical committee 146-air quality: recommendations on size definitions for particle sampling. *Am. Ind. Hyg. Assoc. J.* 42(5): A64-A68.
- Iregren, A. (1990) Psychological test performance in foundry workers exposed to low levels of manganese. *Neurotoxicol. Teratol.* 12: 673-675.
- James, R. C. (1985) Risk assessment. In: Williams, P. L.; Burson, J. L., eds. *Industrial toxicology: safety and health applications in the workplace*. New York, NY: Van Nostrand Reinhold Company; pp. 369-398.

- Jarabek, A. M. (1991) Meeting to identify ventilation rate and respiratory surface area default values for use in the inhalation RfC methodology [memorandum to attendees for August 14, 1991 meeting]. Research Triangle Park, NC: U.S. Environmental Protection Agency, Environmental Criteria and Assessment Office; August 7.
- Jarabek, A. M. (1994) Inhalation RfC methodology: dosimetric adjustments and dose-response estimation of noncancer toxicity in the upper respiratory tract. *Inhal. Toxicol.* 6(suppl.): 301-325.
- Jarabek, A. M.; Farland, W. H. (1990) The U.S. Environmental Protection Agency's risk assessment guidelines. *Toxicol. Ind. Health* 6: 199-216.
- Jarabek, A. M.; Hasselblad, V. (1991) Inhalation reference concentration methodology: impact of dosimetric adjustments and future directions using the confidence profile method. Presented at: 84th annual meeting and exhibition of the Air and Waste Management Association; June; Vancouver, BC, Canada. Pittsburgh, PA: Air and Waste Management Association; paper no. 91-173.3.
- Jarabek, A. M.; Segal, S. A. (1994) Noncancer toxicity of inhaled air toxics: available approaches for risk assessment and risk management. In: Patrick, D. R., ed. *Toxic air pollution handbook*. New York, NY: Van Nostrand Reinhold; pp. 100-130.
- Jarabek, A. M.; Ménache, M. G.; Overton, J. H., Jr.; Dourson, M. L.; Miller, F. J. (1989) Inhalation reference dose (RfDi): an application of interspecies dosimetry modeling for risk assessment of insoluble particles. In: *Proceedings of the 26th Hanford life sciences symposium, "modeling for scaling to man,"* October 1987; Richland, WA. *Health Phys.* 57(suppl. 1): 177-183.
- Jarabek, A. M.; Ménache, M. G.; Overton, J. H., Jr.; Dourson, M. L.; Miller, F. J. (1990) The U.S. Environmental Protection Agency's inhalation RfD methodology: risk assessment for air toxics. *Toxicol. Ind. Health* 6: 279-301.
- Jeffery, P. K. (1983) Morphologic features of airway surface epithelial cells and glands. *Am. Rev. Respir. Dis.* 128: S14-S20.
- Jepson, G. W.; Hoover, D. K.; Black, R. K.; McCafferty, J. D.; Mahle, D. A.; Gearhart, J. M. (1994) A partition coefficient determination method for nonvolatile chemicals in biological tissues. *Fundam. Appl. Toxicol.* 22: 519-524.
- Johanson, W. G., Jr.; Gould, K. G., Jr. (1977) Lung defense mechanisms. *Basics Respir. Dis.* 6(2): 1-6.
- Kane, L. E.; Barrow, C. S.; Alarie, Y. (1979) A short-term test to predict acceptable levels of exposure to airborne sensory irritants. *Am. Ind. Hyg. Assoc. J.* 40: 207-229.
- Karol, M. H. (1994) Assays to evaluate pulmonary hypersensitivity. In: Burleson, G. R.; Dean, J. H.; Munson, A. E., eds. *Modern methods in immunotoxicology*. New York, NY: Wiley-Liss.
- Karol, M. H.; Stadler, J.; Magreni, C. M. (1985) Immunotoxicologic evaluation of the respiratory system: animal models for immediate- and delayed-onset pulmonary hypersensitivity. *Fundam. Appl. Toxicol.* 5: 459-472.
- Kehrer, J. P.; Kacew, S. (1985) Systemically applied chemicals that damage lung tissue. *Toxicology* 35: 251-293.
- Kenoyer, J. L.; Phalen, R. F.; Davis, J. R. (1981) Particle clearance from the respiratory tract as a test of toxicity: effect of ozone on short and long term clearance. *Exp. Lung Res.* 2: 111-120.

- Khoury, M. J.; Newill, C. A.; Chase, G. A. (1985) Epidemiologic evaluation of screening for risk factors: application to genetic screening. *Am. J. Public Health* 75: 1204-1208.
- Kimbell, J. S.; Gross, E. A.; Joyner, D. R.; Godo, M. N.; Morgan, K. T. (1993) Application of computational fluid dynamics to regional dosimetry of inhaled chemicals in the upper respiratory tract of the rat. *Toxicol. Appl. Pharmacol.* 121: 253-263.
- Kimmel, C. A.; Gaylor, D. W. (1988) Issues in qualitative and quantitative risk analysis for developmental toxicology. *Risk Anal.* 8: 15-20.
- Klaassen, C. D. (1986) Principles of toxicology. In: Klaassen, C. D.; Amdur, M. O.; Doull, J., eds. *Casarett and Doull's toxicology: the basic science of poisons*. 3rd ed. New York, NY: MacMillan Publishing Co., Inc.; pp. 11-32.
- Kleinman, M. T. (1984) Sulfur dioxide and exercise: relationships between response and absorption in upper airways. *J. Air Pollut. Control Assoc.* 34: 32-37.
- Kliment, V. (1973) Similarity and dimensional analysis, evaluation of aerosol deposition in the lungs of laboratory animals and man. *Folia Morphol. (Prague)* 21: 59-64.
- Knudson, R. J.; Burrows, B.; Lebowitz, M. D. (1976) The maximal expiratory flow-volume curve: its use in the detection of ventilatory abnormalities in a population study. *Am. Rev. Respir. Dis.* 114: 871-879.
- Kokoski, C. J. (1976) [Written testimony of Charles J. Kokoski, docket no. 76N-0070]. Washington, DC: U.S. Department of Health, Education and Welfare, Food and Drug Administration.
- Krewski, D.; Brown, C.; Murdoch, D. (1984) Determining "safe" levels of exposure: safety factors or mathematical models? *Fundam. Appl. Toxicol.* 4: S383-S394.
- Kurzel, R. B.; Cetrulo, C. L. (1981) The effect of environmental pollutants on human reproduction, including birth defects. *Environ. Sci. Technol.* 15: 626-640.
- Kuykendall, J. R.; Taylor, M. L.; Bogdanffy, M. S. (1993) Cytotoxicity and DNA-protein crosslink formation in rat nasal tissues exposed to vinyl acetate are carboxylesterase-mediated. *Toxicol. Appl. Pharmacol.* 123: 283-292.
- Last, J. A. (1983) Biochemical alterations of lung structure as predictors of chronic lung disease. *Environ. Health Perspect.* 52: 159-163.
- Lebowitz, M. D. (1983) Utilization of data from human population studies for setting air quality standards: evaluation of important issues. *Environ. Health Perspect.* 52: 193-205.
- Lechner, A. J. (1978) The scaling of maximal oxygen consumption and pulmonary dimensions in small mammals. *Respir. Physiol.* 34: 29-44.
- Leung, H.-W. (1992) Use of physiologically based pharmacokinetic models to establish biological exposure indexes. *Am. Ind. Hyg. Assoc. J.* 53: 369-374.
- Leung, H.-W.; Paustenbach, D. J. (1988) Application of pharmacokinetics to derive biological exposure indexes from threshold limit values. *Am. Ind. Hyg. Assoc. J.* 49: 445-450.
- Lewis, S. C.; Lynch, J. R.; Nikiforov, A. I. (1990) A new approach to deriving community exposure guidelines from "no-observed-adverse-effect levels." *Reg. Toxicol. Pharmacol.* 11: 314-330.

- Lippmann, M. (1970) Deposition and clearance of inhaled particles in the human nose. *Ann. Otol. Rhinol. Laryngol.* 79: 519-528.
- Lippmann, M. (1977) Regional deposition of particles in the human respiratory tract. In: Lee, D. H. K.; Falk, H. L.; Murphy, S. D.; Geiger, S. R., eds. *Handbook of physiology, section 9: reactions to physical agents*. Bethesda, MD: American Physiological Society; pp. 213-232.
- Lippmann, M. (1980) Aerosol exposure methods. In: Willeke, K., ed. *Generation of aerosols and facilities for exposure experiments*. Ann Arbor, MI: Ann Arbor Science Publishers, Inc.; pp. 443-458.
- Lippmann, M.; Albert, R. E. (1969) The effect of particle size on the regional deposition of inhaled aerosols in the human respiratory tract. *Am. Ind. Hyg. Assoc. J.* 00: 257-275.
- Lippmann, M.; Schlesinger, R. B. (1984) Interspecies comparisons of particle deposition and mucociliary clearance in tracheobronchial airways. *J. Toxicol. Environ. Health* 13: 441-469.
- Litterst, C. L.; Mimnaugh, E. G.; Reagan, R. L.; Gram, T. E. (1975) Comparison of in vitro drug metabolism by lung, liver, and kidney of several common laboratory species. *Drug Metab. Dispos.* 3: 259-265.
- Lou, S.-R. (1993) Modeling of gas absorption: upper airway scrubbing [submitted dissertation]. Baltimore, MD: The Johns Hopkins University.
- Lowry, L. K. (1986) Biological exposure index as a complement to the TLV. *J. Occup. Med.* 28: 578-582.
- Lu, F. C. (1983) Toxicological evaluations of carcinogens and noncarcinogens: pros and cons of different approaches. *Regul. Toxicol. Pharmacol.* 3: 121-132.
- Lu, F. C. (1985a) Basic toxicology: fundamentals, target organs, and risk assessment. New York, NY: Hemisphere Publishing Corporation.
- Lu, F. C. (1985b) Safety assessments of chemicals with thresholded effects. *Regul. Toxicol. Pharmacol.* 5: 460-464.
- Lyman, W. J.; Reehl, W. F.; Rosenblatt, D. H. (1990) *Handbook of chemical property estimation methods: environmental behavior of organic compounds*. Washington, DC: American Chemical Society.
- Marin, M. G. (1986) Pharmacology of airway secretion. *Pharmacol. Rev.* 38: 273-289.
- Marple, V. A.; Rubow, K. L. (1980) Aerosol generation concepts and parameters. In: Willeke, K., ed. *Generation of aerosols and facilities for exposure experiments*. Ann Arbor, MI: Ann Arbor Science Publishers, Inc.; pp. 3-29.
- Martonen, T. B. (1982) Analytical model of hygroscopic particle behavior in human airways. *Bull. Math. Biol.* 44: 425-442.
- Martonen, T. B.; Miller, F. J. (1986) Dosimetry and species sensitivity: key factors in hazard evaluation using animal exposure data. *J. Aerosol Sci.* 17: 316-319.
- Martonen, T. B.; Patel, M. (1981) Modeling the dose distribution of H₂SO₄ aerosols in the human tracheobronchial tree. *Am. Ind. Hyg. Assoc. J.* 42: 453-460.
- Martonen, T. B.; Barnett, A. E.; Miller, F. J. (1985) Ambient sulfate aerosol deposition in man: modeling the influence of hygroscopicity. *Environ. Health Perspect.* 63: 11-24.

- Massaro, E. J.; Grose, E. C.; Hatch, G. E.; Slade, R. (1988) Antioxidant defense mechanisms of the lung. In: Gardner, D. E.; Crapo, J. D.; Massaro, E. J., eds. *Toxicology of the lung*. New York, NY: Raven Press; pp. 201-218. (Target organ toxicology series).
- Mauderly, J. L. (1989) Effect of inhaled toxicants on pulmonary function. In: McClellan, R. O.; Henderson, R. F., eds. *Concepts in inhalation toxicology*. New York, NY: Hemisphere Publishing; pp. 347-401.
- Mauderly, J. L.; Kritchevsky, J. (1979) Respiration of unsedated Fischer 344 rats and the effect of confinement in exposure tubes. In: Henderson, R. F.; Diel, J. H.; Martinez, B. S., eds. *Inhalation Toxicology Research Institute annual report 1978-1979*. Albuquerque, NM: U.S. Department of Energy, Lovelace Biomedical and Environmental Research Institute; report no. LMF-69; pp. 475-478. Available from: NTIS, Springfield, VA; LMF-69.
- Mauderly, J. L.; Tesarek, J. E.; Sifford, L. J.; Sifford, L. J. (1979) Respiratory measurements of unsedated small laboratory mammals using nonbreathing valves. *Lab. Anim. Sci.* 29: 323-329.
- McCauley, P. T.; Bull, R. J. (1980) Experimental approaches to evaluating the role of environmental factors in the development of cardiovascular disease. *J. Environ. Pathol. Toxicol.* 4: 27-50.
- McJilton, C.; Thielke, J.; Frank, R. (1972) Ozone uptake model for the respiratory system. Presented at: American Industrial Hygiene Association conference; May; San Francisco, CA. Seattle, WA: University of Washington, Departments of Civil Engineering and Environmental Health.
- McKay, R. T. (1986) Bronchoprovocation challenge testing in occupational airways disorders. *Semin. Respir. Med.* 7: 297-306.
- McKay, R. T.; Lockey, J. E. (1991) Pulmonary function testing: guidelines for medical surveillance and epidemiological studies. *Occup. Med.* 6: 43-57.
- McKenna, M. J. (1982) Production and characterization of exposure atmospheres: vapors and gases. Presented at: Third AIHA/Lovelace inhalation toxicology workshop; September; Albuquerque, NM.
- McNamara, B. P. (1976) Concepts in health evaluation of commercial and industrial chemicals. In: Mehlman, M. A.; Shapiro, R. E.; Blumenthal, H., eds. *New concepts in safety evaluation*. Washington, DC: Hemisphere Publishing Corporation; pp. 61-140. (Advances in modern toxicology: volume 1, part 1).
- Means, B. (1989) Risk assessment guidance for Superfund. Volume 1. Human health evaluation manual. Part A. Washington, DC: U.S. Environmental Protection Agency, Office of Solid Waste and Emergency Response; EPA report no. EPA/540/1-89/002. Available from: NTIS, Springfield, VA; PB90-155581/XAB.
- Medical Research Council, Committee on the Aetiology of Chronic Bronchitis. (1960) Standardized questionnaires on respiratory symptoms. *Br. Med. J.* 2: 1665.
- Ménache, M. G.; Raabe, O. G.; Miller, F. J. (submitted) An empirical dosimetry model of aerodynamic particle deposition in the rat respiratory tract. *Inhalation Toxicol.*: submitted.
- Ménache, M. G.; Miller, F. J.; Raabe, O. G. (1995) Particle inhalability curves for humans and small laboratory animals. *Ann. Occup. Hyg.* 39: 317-328.
- Meneely, G. R.; Renzetti, A. D., Jr.; Steele, J. D.; Wyatt, J. P.; Harris, H. W. (1962) Chronic bronchitis, asthma, and pulmonary emphysema: a statement by the Committee on Diagnostic Standards for Nontuberculous Respiratory Diseases. *Am. Rev. Respir. Dis.* 85: 762-768.

- Menzel, D. B.; Amdur, M. O. (1986) Toxic responses of the respiratory system. In: Klaassen, C. D.; Amdur, M. O.; Doull, J., eds. Casarett and Doull's toxicology: the basic science of poisons. 3rd ed. New York, NY: Macmillan Publishing Company; pp. 330-358, 428, 430.
- Mercer, R. R.; Crapo, J. D. (1987) Three-dimensional reconstruction of the rat acinus. *J. Appl. Physiol.* 63: 785-794.
- Mercer, T. T.; Tillery, M. I.; Chow, H. Y. (1968) Operation characteristics of some compressed air nebulizers. *Am. Ind. Hyg. Assoc.* 29: 66.
- Mercer, R. R.; Russell, M. L.; Roggli, V. L.; Crapo, J. D. (1994a) Cell number and distribution in human and rat airways. *Am. J. Respir. Cell Mol. Biol.* 10: 613-624.
- Mercer, R. R.; Russell, M. L.; Crapo, J. D. (1994b) Alveolar septal structure in different species. *J. Appl. Physiol.* 77(3): in press.
- Mery, S.; Gross, E. A.; Joyner, D. R.; Godo, M.; Morgan, K. T. (1994) Nasal diagrams: a tool for recording the distribution of nasal lesions in rats and mice. *Toxicol. Pathol.* 22(4): in press.
- Miller, F. J.; Gardner, D. E.; Graham, J. A.; Lee, R. E., Jr.; Wilson, W. E.; Bachmann, J. D. (1979) Size considerations for establishing a standard for inhalable particles. *J. Air Pollut. Control Assoc.* 29: 610-615.
- Miller, F. J.; Graham, J. A.; Gardner, D. E. (1983a) The changing role of animal toxicology in support of regulatory decisions. *Environ. Health Perspect.* 52: 169-176.
- Miller, F. J.; Graham, J. A.; Overton, J. H., Jr. (1983b) General considerations for developing pulmonary extrapolation models. In: Proceedings of the conference on environmental toxicology (13th); November 1982; Dayton, OH. Wright- Patterson AFB, OH: Air Force Aerospace Medical Research Laboratory; report no. AFAMRL-TR-82-101; pp. 178-208. Available from: NTIS, Springfield, VA; AD-A134 150.
- Miller, F. J.; Overton, J. H., Jr.; Jaskot, R. H.; Menzel, D. B. (1985) A model of the regional uptake of gaseous pollutants in the lung: I. the sensitivity of the uptake of ozone in the human lung to lower respiratory tract secretions and exercise. *Toxicol. Appl. Pharmacol.* 79: 11-27.
- Miller, F. J.; Graham, J. A.; Raub, J. A.; Illing, J. W.; Ménache, M. G.; House, D. E.; Gardner, D. E. (1987a) Evaluating the toxicity of urban patterns of oxidant gases. II. Effects in mice from chronic exposure to nitrogen dioxide. *J. Toxicol. Environ. Health* 21: 99-112.
- Miller, F. J.; Overton, J. H., Jr.; Smolko, E. D.; Graham, R. C.; Menzel, D. B. (1987b) Hazard assessment using an integrated physiologically based dosimetry modeling approach: ozone. In: *Pharmacokinetics in risk assessment, drinking water and health*, v. 8. Washington, DC: National Academy Press; pp. 353-368.
- Miller, F. J.; Martonen, T. B.; Ménache, M. G.; Graham, R. C.; Spektor, D. M.; Lippmann, M. (1988) Influence of breathing mode and activity level on the regional deposition of inhaled particles and implications for regulatory standards. In: Dodgson, J.; McCallum, R. I.; Bailey, M. R.; Fisher, D. R., eds. *Inhaled particles VI: proceedings of an international symposium and workshop on lung dosimetry*; September 1985; Cambridge, United Kingdom. *Ann. Occup. Hyg.* 32 (suppl. 1): 3-10.
- Minchin, R. F.; Boyd, M. R. (1983) Localization of metabolic activation and deactivation systems in the lung: significance to the pulmonary toxicity of xenobiotics. *Annu. Rev. Pharmacol. Toxicol.* 23: 217-238.

- Moller, D. R.; Baughman, R.; Murlas, C.; Brooks, S. M. (1986) New directions in occupational asthma caused by small molecular weight compounds. *Semin. Respir. Med.* 7: 225-239.
- Monks, T. J.; Lau, S. S. (1989) Sulphur conjugate-mediated toxicity. *Rev. Biochem. Toxicol.* 10: 41-90.
- Monson, R. R. (1986) Observations on the healthy worker effect. *J. Occup. Med.* 28: 425-433.
- Monticello, T. M.; Morgan, K. T.; Everitt, J. I.; Popp, J. A. (1989) Effects of formaldehyde gas on the respiratory tract of rhesus monkeys: pathology and cell proliferation. *Am. J. Pathol.* 134: 515-527.
- Morgan, K. T. (1991) Approaches to the identification and recording of nasal lesions in toxicology studies. *Toxicol. Pathol.* 19: 337-351.
- Morgan, M. S.; Frank, R. (1977) Uptake of pollutant gases by the respiratory system. In: Brain, J. D.; Proctor, D. F.; Reid, L. M., eds. *Respiratory defense mechanisms: part I.* New York, NY: Marcel Dekker, Inc.; pp. 157-189.
- Morgan, K. T.; Jiang, X.-Z.; Patterson, D. L.; Gross, E. A. (1984) The nasal mucociliary apparatus: correlation of structure and function in the rat. *Am. Rev. Respir. Dis.* 130: 275-281.
- Morgan, K. T.; Jiang, X.-Z.; Starr, T. B.; Kerns, W. D. (1986) More precise localization of nasal tumors associated with chronic exposure of F-344 rats to formaldehyde gas. *Toxicol. Appl. Pharmacol.* 82: 264-271.
- Morgan, K. T.; Kimbell, J. S.; Monticello, T. M.; Patra, A. L.; Fleishman, A. (1991) Studies of inspiratory airflow patterns in the nasal passages of the F344 rat and rhesus monkey using nasal molds: relevance to formaldehyde toxicity. *Toxicol. Appl. Pharmacol.* 110: 223-240.
- Morris, J. B. (1989) Deposition and absorption of inhaled vapors in the nasal cavity. In: Feron; Bosland, eds. *Nasal carcinogenesis in rodents: relevance to human health risk*; pp. 113-118.
- Morris, J. B. (1990) First-pass metabolism of inspired ethyl acetate in the upper respiratory tracts of the F344 rat and Syrian hamster. *Toxicol. Appl. Pharmacol.* 102: 331-345.
- Morris, J. B.; Blanchard, K. T. (1992) Upper respiratory tract deposition of inspired acetaldehyde. *Toxicol. Appl. Pharmacol.* 114: 140-146.
- Morris, J. B.; Cavanagh, D. G. (1986) Deposition of ethanol and acetone vapors in the upper respiratory tract of the rat. *Fundam. Appl. Toxicol.* 6: 78-88.
- Morris, J. B.; Cavanagh, D. G. (1987) Metabolism and deposition of propanol and acetone vapors in the upper respiratory tract of the hamster. *Fundam. Appl. Toxicol.* 9: 34-40.
- Morris, J. B.; Smith, F. A. (1982) Regional deposition and absorption of inhaled hydrogen fluoride in the rat. *Toxicol. Appl. Pharmacol.* 62: 81-89.
- Morris, J. B.; Clay, R. J.; Cavanagh, D. G. (1986) Species differences in upper respiratory tract deposition of acetone and ethanol vapors. *Fundam. Appl. Toxicol.* 7: 671-680.
- Morris, J. B.; Clay, R. J.; Trela, B. A.; Bogdanffy, M. S. (1991) Deposition of dibasic esters in the upper respiratory tract of the male and female Sprague-Dawley rat. *Toxicol. Appl. Pharmacol.* 108: 538-546.
- Morrow, P. E. (1988) Possible mechanisms to explain dust overloading of the lungs. *Fundam. Appl. Toxicol.* 10: 369-384.

- Morrow, P. E. (1992) Dust overloading of the lungs: update and appraisal. *Toxicol. Appl. Pharmacol.* 113: 1-12.
- Moss, O. R.; Cheng, Y.-S. (1989) Generation and characterization of test atmospheres: particles. In: McClellan, R. O.; Henderson, R. F., eds. *Concepts in inhalation toxicology*; New York, NY: Hemisphere Publishing Corp.; pp. 85-120.
- Muller, K. E.; Barton, C. N.; Benignus, V. A. (1984) Recommendations for appropriate statistical practice in toxicologic experiments. *Neurotoxicology* 5: 113-125.
- Mustafa, M. G.; Lee, S. D. (1976) Pulmonary biochemical alterations resulting from ozone exposure. *Ann. Occup. Hyg.* 19: 17-26.
- Nadel, J. A.; Widdicombe, J. H.; Peatfield, A. C. (1986) Regulation of airway secretions, in transport and water movement. In: *Handbook of physiology*; pp. 414-445.
- National Center for Health Statistics. (1970) *Natality statistics analysis, United States, 1965-1967*. Washington, DC: Public Health Service, National Center for Health Statistics; report no. PHS No. 1000. (Vital and health statistics series 21, no. 19).
- National Center for Health Statistics. (1975) *Selected vital and health statistics in poverty and nonpoverty areas of 19 large cities, United States, 1969-1971*. Washington, DC: Public Health Service, National Center for Health Statistics. (Vital and health statistics series 21, no. 26).
- National Institute for Occupational Safety and Health. (1986) *NIOSH cross-sectional and reproductive medical industry-wide studies questionnaire*. Cincinnati, OH: National Institute for Occupational Safety and Health; report no. OMB 0920-0037.
- National Research Council. (1977) *Drinking water and health*. Washington, DC: National Academy of Sciences; pp. 801-804.
- National Research Council. (1980) *Drinking water and health, v. 2*. Washington, DC: National Academy Press.
- National Research Council. (1983) *Risk assessment in the federal government: managing the process*. Washington, DC: National Academy Press.
- National Research Council. (1984) *Toxicity testing: strategies to determine needs and priorities*. Washington, DC: National Academy Press.
- National Research Council. (1985) *Epidemiology and air pollution*. Washington, DC: National Academy Press. Available from: NTIS, Springfield, VA; PB86-137163.
- National Research Council. (1986) *Dose-route extrapolations: using inhalation toxicity data to set drinking water limits*. In: *Drinking water and health: v. 6*. Washington, DC: National Academy Press; pp. 168-204.
- National Research Council. (1987) *Pharmacokinetics in risk assessment: drinking water and health, v. 8*. Washington, DC: National Academy Press.
- National Research Council. (1991a) *Human exposure assessment for airborne pollutants: advances and opportunities*. Washington, DC: National Academy Press.
- National Research Council. (1991b) *Environmental epidemiology; v.1: public health and hazardous wastes*. Washington, DC: National Academy Press.

- National Research Council. (1994) Science and judgment in risk assessment. Washington, DC: National Academy Press.
- National Toxicology Program. (1986) Toxicology and carcinogenesis studies of xylenes (mixed) (60% m-xylene, 14% p-xylene, 9% o-xylene, and 17% ethylbenzene) (CAS no. 1330-20-7) in F344/N rats and B6C3F1 mice (gavage studies). Research Triangle Park, NC: U.S. Department of Health and Human Services, National Institutes of Environmental Health and Safety; report no. NIH /PUB-87-2583. (National Toxicology Program technical report series no. NTP-TR-327). Available from: NTIS, Springfield, VA; PB87-189684/AS.
- Nuckols, M. L. (1981) Heat and water vapor transfer in the human respiratory system at hyperbaric conditions. Naval Coastal Systems Center technical report; report no: TR364-81.
- O'Brien, K. A. F.; Smith, L. L.; Cohen, G. M. (1985) Differences in naphthalene-induced toxicity in the mouse and rat. *Chem.-Biol. Interact.* 55: 109-122.
- O'Flaherty, E. J. (1981) Dose, response relationships. In: *Toxicants and drugs: kinetics and dynamics*. New York, NY: John Wiley & Sons; pp. 354-389.
- O'Flaherty, E. J. (1989) Interspecies conversion of kinetically equivalent doses. *Risk Anal.* 9: 587-598.
- Oberdörster, G. (1990) Equivalent oral and inhalation exposure to cadmium compounds: risk estimation based on route-to-route extrapolation. In: Gerrity, T. R.; Henry, C. J., eds. *Principles of route-to-route extrapolation for risk assessment, proceedings of the workshops; March and July; Hilton Head, SC and Durham, NC*. New York, NY: Elsevier Science Publishing Co., Inc.; pp. 217-235.
- Ohmiya, Y.; Mehendale, H. M. (1984) Species differences in pulmonary N-oxidation of chlorpromazine and imipramine. *Pharmacology* 28: 289-295.
- Orr, C., Jr.; Keng, E. Y. H. (1976) Sampling and particle-size measurement. In: Dennis, R., ed. *Handbook on aerosols*. Oak Ridge, TN: U.S. Energy Research and Development Administration, Technical Information Center; pp. 93-117. Available from: NTIS, Springfield, VA; TID-26608.
- Overton, J. H., Jr. (1984) Physicochemical processes and the formulation of dosimetry models. In: Miller, F. J.; Menzel, D. B., eds. *Fundamentals of extrapolation modeling of inhaled toxicants: ozone and nitrogen dioxide*. Washington, DC: Hemisphere Publishing Corporation; pp. 93-114.
- Overton, J. H., Jr. (1989) A respiratory tract dosimetry model for air toxics. Presented at: U.S.-Dutch expert workshop on air toxics; May 1988; Amersfoort, The Netherlands. *Toxicol. Ind. Health* 6: 171-180.
- Overton, J. H.; Graham, R. C. (1994) Modeling the uptake of gases by the dog nasal-pharyngeal region: effects of morphometric and physicochemical factors. *Inhal. Toxicol.* 6(suppl.): 113-124.
- Overton, J. H.; Jarabek, A. M. (1989a) Estimating equivalent human concentrations of no observed adverse effect levels: a comparison of several methods. In: *Proceedings of a symposium—assessment of inhalation hazards: integration and extrapolation using diverse data; February; Hannover, Federal Republic of Germany*. *Exp. Pathol.* 37: 89-94.
- Overton, J. H.; Jarabek, A. M. (1989b) Estimating human equivalent no observed adverse effects levels for VOCs based on minimal knowledge of physiological parameters. Presented at: 82nd annual meeting of the Air and Waste Management Association; June; Anaheim, CA. Pittsburgh, PA: Air and Waste Management Association; paper no. 89-91.8.

- Overton, J. H.; Miller, F. J. (1988) Absorption of inhaled reactive gases. In: Gardner, D. E.; Crapo, J. D.; Massaro, E. J., eds. Toxicology of the lung. New York, NY: Raven Press; pp. 477-507. (Target organ toxicology series).
- Overton, J. H.; Graham, R. C.; Miller, F. J. (1987) A model of the regional uptake of gaseous pollutants in the lung: II. the sensitivity of ozone uptake in laboratory animal lungs to anatomical and ventilatory parameters. *Toxicol. Appl. Pharmacol.* 88: 418-432.
- Padgett, J.; Richmond, H. (1983) The process of establishing and revising national ambient air quality standards. *J. Air Pollut. Control Assoc.* 33: 13-16.
- Paiva, M. (1973) Gas transport in the human lung. *J. Appl. Physiol.* 35: 401-410.
- Pang, K. S.; Rowland, M. (1977) Hepatic clearance of drugs. I. Theoretical considerations of a "well-stirred" model and a "parallel tube" model. Influence of hepatic blood flow, plasma and blood cell binding, and the hepatocellular enzymatic activity on hepatic drug clearance. *J. Pharmacokinet. Biopharm.* 5: 625-653.
- Patra, A. L. (1986) Comparative anatomy of mammalian respiratory tracts: the nasopharyngeal region and the tracheobronchial region. *J. Toxicol. Environ. Health* 17: 163-174.
- Patra, A. L.; Gooya, A.; Ménache, M. G. (1986) A morphometric comparison of the nasopharyngeal airway of laboratory animals and humans. *Anat. Rec.* 215: 42-50.
- Pepelko, W. E. (1987) Feasibility of dose adjustment based on differences in long-term clearance rates of inhaled particulate matter in humans and laboratory animals. *Regul. Toxicol. Pharmacol.* 7: 236-252.
- Pepelko, W. E.; Withey, J. R. (1985) Methods for route-to-route extrapolation of dose. *Toxicol. Ind. Health* 1: 153-171.
- Perera, F. (1987) The potential usefulness of biological markers in risk assessment. *Environ. Health Perspect.* 76: 141-145.
- Perera, F. P.; Weinstein, I. B. (1982) Molecular epidemiology and carcinogen-DNA adduct detection: new approaches to studies of human cancer causation. *J. Chron. Dis.* 35: 581-600.
- Perlin, S. A.; McCormack, C. (1988) Using weight-of-evidence classification schemes in the assessment of non-cancer health risks. In: HWHM '88, proceedings of the 5th national conference on hazardous wastes and hazardous materials; April; Las Vegas, NV. Springfield, MD: Hazardous Materials Control Research Institute; pp. 482-486.
- Perry, R. H.; Chilton, C. H. (1973) *Chemical engineers' handbook*. 5th ed. New York, NY: McGraw-Hill Book Company.
- Phalen, R. F.; Oldham, M. J. (1983) Tracheobronchial airway structure as revealed by casting techniques. *Am. Rev. Respir. Dis.* 128: S1-S4.
- Phalen, R. F.; Stuart, B. O.; Liroy, P. J. (1988) Rationale for and implications of particle size-selective sampling. In: *Advances in air sampling: [papers from the ACGIH symposium]; February 1987; Pacific Grove, CA. Chelsea, MI: Lewis Publishers, Inc.; p. 6. (Industrial hygiene science series).*
- Pickrel, C. A.; Samuhel, M. E.; Chesson, J. (1986) *Quality assurance in epidemiologic studies*. Washington, DC: Battelle, Columbus Laboratories; contract no. 68-02-4246.

- Plopper, C. G.; Mariassy, A. T.; Hill, L. H. (1980) Ultrastructure of the nonciliated bronchiolar epithelial (Clara) cell of mammalian lung: I. a comparison of rabbit, guinea pig, rat, hamster, and mouse. *Exp. Lung Res.* 1: 139-154.
- Plopper, C. G.; Mariassy, A. T.; Wilson, D. W.; Alley, J. L.; Nishio, S. J.; Nettesheim, P. (1983) Comparison of nonciliated tracheal epithelial cells in six mammalian species: ultrastructure and population densities. *Exp. Lung Res.* 5: 281-294.
- Portier, C. J.; Kaplan, N. L. (1989) Variability of safe dose estimates when using complicated models of the carcinogenic process. *Fundam. Appl. Toxicol.* 13: 533-544.
- Raabe, O. G. (1971) Particle size analysis utilizing grouped data and the log-normal distribution. *J. Aerosol Sci.* 2: 289-303.
- Raabe, O. G. (1976) Aerosol aerodynamic size conventions for inertial sampler calibration. *J. Air Pollut. Control Assoc.* 26: 856-860.
- Raabe, O. G. (1979) Deposition and clearance of inhaled aerosols. Washington, DC: U.S. Department of Energy, Laboratory for Energy-Related Health Research; report no. UCD-472-503. Available from: NTIS, Springfield, VA; UCD-472-503.
- Raabe, O. G.; Bennick, J. E.; Light, M. E.; Hobbs, C. H.; Thomas, R. L.; Tillery, M. I. (1973) An improved apparatus for acute inhalation exposure of rodents to radioactive aerosols. *Toxicol. Appl. Pharmacol.* 26: 264-273.
- Raabe, O. G.; Yeh, H.-C.; Newton, G. J.; Phalen, R. F.; Velasquez, D. J. (1977) Deposition of inhaled monodisperse aerosols in small rodents. In: Walton, W. H.; McGovern, B., eds. *Inhaled particles IV, part 1: proceedings of an international symposium; September 1975; Edinburgh, Scotland.* Oxford, United Kingdom: Pergamon Press, Ltd.; pp. 3-21.
- Raabe, O. G.; Al-Bayati, M. A.; Teague, S. V.; Rasolt, A. (1988) Regional deposition of inhaled monodisperse, coarse, and fine aerosol particles in small laboratory animals. In: Dodgson, J.; McCallum, R. I.; Bailey, M. R.; Fischer, D. R., eds. *Inhaled particles VI: proceedings of an international symposium and workshop on lung dosimetry; September 1985; Cambridge, United Kingdom.* *Ann. Occup. Hyg.* 32 (suppl. 1): 53-63.
- Ramsey, J. C.; Andersen, M. E. (1984) A physiologically based description of the inhalation pharmacokinetics of styrene in rats and humans. *Toxicol. Appl. Pharmacol.* 73: 159-175.
- Redmond, C. K. (1981) Sensitive population subsets in relation to effects of low doses. *Environ. Health Perspect.* 42: 137-140.
- Reeves, A. L.; Deitch, D.; Vorwald, A. J. (1967) Beryllium carcinogenesis: I. inhalation exposure of rats to beryllium sulfate aerosol. *Cancer Res.* 27: 439-445.
- Reid, L. M. (1980) Needs for animal models of human diseases of the respiratory system. *Am. J. Pathol.* 101: S89-S101.
- Reitz, R. H.; McDougal, J. N.; Himmelstein, M. W.; Nolan, R. J.; Schumann, A. M. (1988) Physiologically based pharmacokinetic modeling with methylchloroform: implications for interspecies, high dose/low dose, and dose route extrapolations. *Toxicol. Appl. Pharmacol.* 95: 185-199.
- Renwick, A. G. (1991) Safety factors and establishment of acceptable daily intakes. *Food Addit. Contam.* 8: 135-149.

- Rhoads, K.; Sanders, C. L. (1985) Lung clearance, translocation, and acute toxicity of arsenic, beryllium, cadmium, cobalt, lead, selenium, vanadium, ytterbium oxides following deposition in the rat lung. *Environ. Res* 36: 359-378.
- Rice, J. M. (1981) Prenatal susceptibility to carcinogenesis by xenobiotic substances including vinyl chloride. *Environ. Health Perspect.* 41: 179-188.
- Roels, H.; Lauwerys, R.; Buchet, J.-P.; Genet, P.; Sarhan, M. J.; Hanotiau, I.; de Fays, M.; Bernard, A.; Stanesco, D. (1987a) Epidemiological survey among workers exposed to manganese: effects on lung, central nervous system, and some biological indices. *Am. J. Ind. Med.* 11: 307-327.
- Roels, H.; Lauwerys, R.; Genet, P.; Sarhan, M. J.; de Fays, M.; Hanotiau, I.; Buchet, J.-P. (1987b) Relationship between external and internal parameters of exposure to manganese in workers from a manganese oxide and salt producing plant. *Am. J. Ind. Med.* 11: 297-305.
- Rossi, G. A. (1986) Bronchoalveolar lavage in the investigation of disorders of the lower respiratory tract. *Eur. J. Respir. Dis.* 69: 293-315.
- Rowland, M. (1985) Physiologic pharmacokinetic models and interanimal species scaling. *Pharmacol. Ther.* 29: 49-68.
- Ruben, Z.; Rousseaux, C. G. (1991) The limitation of toxicologic pathology. In: Haschek, W. M.; Rousseaux, C. G. eds. *Handbook of toxicologic pathology*. New York, NY: Academic Press; pp. 131-142.
- Rudolf, G.; Gebhart, J.; Heyder, J.; Scheuch, G.; Stahlhofen, W. (1988) Mass deposition from inspired polydisperse aerosols. *Ann. Occup. Hyg.* 32: 919-938.
- Ruppel, G. (1979) *Manual of pulmonary function testing*, 2nd ed. St. Louis, MO: The C. V. Mosby Company.
- Saltzman, B. E. (1988) Linear pharmacokinetic models for evaluating unusual work schedules, exposure limits and body burdens of pollutants. *Am. Ind. Hyg. Assoc. J.* 49: 213-225.
- Sanagi, S.; Seki, Y.; Sugimoto, K.; Hirata, M. (1980) Peripheral nervous system functions of workers exposed to n-hexane at a low level. *Int. Arch. Occup. Environ. Health* 47: 69-79.
- Sarlo, K.; Clark, E. D. (1992) A tier approach for evaluating the respiratory allergenicity of low molecular weight chemicals. *Fundam. Appl. Toxicol.* 18: 107-114.
- Saxena, M. C.; Siddiqui, M. K. J.; Bhargava, A. K.; Krishna Murti, C. R.; Kutty, D. (1981) Placental transfer of pesticides in humans. *Arch. Toxicol.* 48: 127-134.
- Schaper, M. (1993) Development of a database for sensory irritants and its use in establishing occupational limits. *Am. Ind. Hyg. Assoc. J.* 54: 488-544.
- Schlesinger, R. B. (1985) Comparative deposition of inhaled aerosols in experimental animals and humans: a review. *J. Toxicol. Environ. Health* 15: 197-214.
- Schreider, J.; Hutchens, J. (1980) Morphology of the guinea pig respiratory tract. *Anat. Rec.* 196: 313-321.
- Schreider, J. P.; Raabe, O. G. (1981) Anatomy of the nasal-pharyngeal airway of experimental animals. *Anat. Rec.* 200: 195-205.
- Schulte, P. A. (1987) Methodologic issues in the use of biologic markers in epidemiologic research. *Am. J. Epidemiol.* 126: 1006-1016.

- Schulte, P. A. (1989) A conceptual framework for the validation and use of biologic markers. *Environ. Res.* 48: 129-144.
- Seinfeld, J. H. (1986) *Atmospheric chemistry and physics of air pollution*. New York, NY: John Wiley and Sons.
- Selgrade, M. K.; Zeiss, C. R.; Karol, M. H.; Sarlo, K.; Kimber, I.; Tepper, J. S.; Henry, M. C. (1994) Workshop on status of test methods for assessing potential of chemicals to induce respiratory allergic reactions. *Inhal. Toxicol.* 6: 303-319.
- Shibko, S. (1981) [Personal communication to M. Dourson documenting safety factors]. December 24.
- Shoaf, C. R. (1993) EPA's inhalation testing guidelines. Presented at: International symposium on respiratory toxicology and risk assessment; October 1992; Hanover, Germany. In press.
- Slauson, D. O.; Hahn, F. F. (1980) Criteria for development of animal models of diseases of the respiratory system: the comparative approach in respiratory disease model development. *Am. J. Pathol.* 101: S103-S129.
- Snider, G. L.; Kleinerman, J.; Thurlbeck, W. M.; Bengali, Z. H. (1985) The definition of emphysema: report of a National Heart, Lung, and Blood Institute, Division of Lung Diseases workshop. *Am. Rev. Respir. Dis.* 132: 182-185.
- Snider, G. L.; Lucey, E. C.; Stone, P. J. (1986) Animal models of emphysema. *Am. Rev. Respir. Dis.* 133: 149-169.
- Snipes, M. B. (1989a) Long-term retention and clearance of particles inhaled by mammalian species. *CRC Crit. Rev. Toxicol.* 20: 175-211.
- Snipes, M. B. (1989b) Species comparisons for pulmonary retention of inhaled particles. In: McClellan, R. O.; Henderson, R. F., eds. *Concepts in inhalation toxicology*. New York, NY: Hemisphere Publishing; pp. 193-227.
- Snipes, M. B.; Boecker, B. B.; McClellan, R. O. (1983) Retention of monodisperse or polydisperse aluminosilicate particles inhaled by dogs, rats, and mice. *Toxicol. Appl. Pharmacol.* 69: 345-362.
- Snyder, W. S.; Cook, M. J.; Nasset, E. S.; Karhausen, L. R.; Howells, G. P.; Tipton, I. H. (1975) Report of the task group on reference man. New York, NY: Pergamon Press. (International Commission on Radiological Protection no. 23).
- Society of Toxicology, Task Force of Past Presidents. (1982) Animal data in hazard evaluation: paths and pitfalls. *Fundam. Appl. Toxicol.* 2: 101-107.
- Sorokin, S. P. (1970) Properties of alveolar cells and tissues that strengthen alveolar defenses. *Arch. Intern. Med.* 126: 450-463.
- St. George, J. A.; Harkema, J. R.; Hyde, D. M.; Plopper, C. G. (1988) Cell populations and structure-function relationships of cells in the airways. In: Gardner, D. E.; Crapo, J. D.; Massaro, E. J., eds. *Target organ toxicology series: toxicology of the lung*. New York, NY: Raven Press, Ltd.; pp. 71-102.
- Stahlhofen, W.; Gebhart, J.; Heyder, J. (1980) Experimental determination of the regional deposition of aerosol particles in the human respiratory tract. *Am. Ind. Hyg. Assoc. J.* 41: 385-398a.

- Stahlhofen, W.; Gebhart, J.; Heyder, J.; Scheuch, G. (1983) New regional deposition data of the human respiratory tract. *J. Aerosol Sci.* 14: 186-188.
- Stahlhofen, W.; Rudolf, G.; James, A. C. (1989) Intercomparison of experimental regional aerosol deposition data. *J. Aerosol Med.* 2: 285-308.
- Stara, J. F.; Erdreich, L. S., eds. (1984a) Approaches to risk assessment for multiple chemical exposures. Cincinnati, OH: U.S. Environmental Protection Agency, Office of Health and Environmental Assessment, Environmental Criteria and Assessment Office; EPA report no. EPA-600/9-84-008. Available from: NTIS, Springfield, VA; PB84-182369.
- Stara, J. F.; Erdreich, L. S., eds. (1984b) Selected approaches to risk assessment for multiple chemical exposures: progress report on guideline development at ECAO-Cincinnati. Cincinnati, OH: U.S. Environmental Protection Agency, Office of Health and Environmental Assessment, Environmental Criteria and Assessment Office; EPA report no. EPA-600/9-84-014a. Available from: NTIS, Springfield, VA; PB84-226992.
- Stara, J. F.; Dourson, M. L.; DeRosa, C. T. (1981) Water quality criteria: methodology and applications. In: Hoch, R. J., ed. Conference proceedings: environmental risk assessment, how new regulations will affect the utility industry; December 1980; New Orleans, LA. Palo Alto, CA: Electric Power Research Institute; pp. 3-1 to 3-18; report no. EPRI/EA-2064.
- Stara, J. F.; Hertzberg, R. C.; Bruins, R. J. F.; Dourson, M. L.; Durkin, P. R.; Erdreich, L. S.; Pepelko, W. E. (1985) Approaches to risk assessment of chemical mixtures. In: Homburger, F.; Marquis, J. K., eds. Chemical safety regulation and compliance: proceedings of a course; October 1983; Cambridge, MA. Basel, Switzerland: Karger; pp. 71-83.
- Stara, J. F.; Bruins, R. J. F.; Dourson, M. L.; Erdreich, L. S.; Hertzberg, R. C.; Durkin, P. R.; Pepelko, W. E. (1987) Risk assessment is a developing science: approaches to improve evaluation of single chemicals and chemical mixtures. In: Vouk, V. B.; Butler, G. C.; Upton, A. C.; Parke, D. V.; Asher, S. C., eds. Methods for assessing the effects of mixtures of chemicals. New York, NY: John Wiley & Sons; pp. 719-743. [Scientific Committee on Problems of the Environment (SCOPE) no. 30; International Program on Chemical Safety (IPCS) joint symposia no. 6].
- Stott, W. T.; McKenna, M. J. (1984) The comparative absorption and excretion of chemical vapors by the upper, lower, and intact respiratory tract of rats. *Fundam. Appl. Toxicol.* 4: 594-602.
- Svartengen, M. (1986) Lung deposition and clearance of particles in healthy persons and patients with bronchiectasis. Stockholm, Sweden.
- Task Group on Lung Dynamics. (1966) Deposition and retention models for internal dosimetry of the human respiratory tract. *Health Phys.* 12: 173-207.
- Tichy, M. (1983) Prediction of adverse activities from physical and chemical properties of vapors and gases (QSAR analysis). In: Fiserova-Bergerova, V., ed. Modeling of inhalation exposure to vapors; v. 2, uptake, distribution and elimination. Boca Raton, FL: CRC Press; pp. 3-35.
- Tenney, S. M.; Remmers, J. E. (1963) Comparative quantitative morphology of the mammalian lung: diffusing area. *Nature (London)* 197: 54-56.
- Travis, C. C.; White, R. K. (1988) Interspecific scaling of toxicity data. *Risk Anal.* 8: 119-125.
- Travis, C. C.; White, R. K.; Ward, R. C. (1990) Interspecies extrapolation of pharmacokinetics. *J. Theor. Biol.* 142: 285-304.

- Trush, M. A.; Mimnaugh, E. G.; Gram, T. E. (1982) Activation of pharmacologic agents to radical intermediates: implications for the role of free radicals in drug action and toxicity. *Biochem. Pharmacol.* 31: 3335-3346.
- Tyl, R. W.; Ballantyne, B.; Fisher, L. C.; Fait, D. L.; Savine, T. A.; Pritts, I. M.; Dodd, D. E. (1994) Evaluation of exposure to water aerosol or air by nose-only or whole-body inhalation procedures for CD-1 mice in developmental toxicity studies. *Fundam. Appl. Toxicol.* 23: 251-260.
- Tyler, W. S.; Tyler, N. K.; Barstow, T.; Magliano, D.; Hinds, D.; Young, M. (1985) Effects in young monkeys of intermittent episodes of exposure to low levels of ozone. *Am. Rev. Respir. Dis.* 131(suppl.): A169.
- Tynes, R. E.; Hodgson, E. (1985) Catalytic activity and substrate specificity of the flavin-containing monooxygenase in microsomal systems: characterization of the hepatic, pulmonary and renal enzymes of the mouse, rabbit, and rat. *Arch. Biochem. Biophys.* 240: 77-93.
- U.S. Department of Health and Human Services. (1994) Vital and health statistics: current estimates from the National Health Interview Survey, 1992. Hyattsville, MD: Public Health Service, National Center for Health Statistics; DHHS publication no. (PHS) 94-1517. (Series 10: data from the National Health Survey no. 189).
- U.S. Environmental Protection Agency. (1982a) Air quality criteria for oxides of nitrogen. Research Triangle Park, NC: Office of Health and Environmental Assessment, Environmental Criteria and Assessment Office; EPA report no. EPA-600/8-82-026. Available from: NTIS, Springfield, VA; PB83-131011.
- U.S. Environmental Protection Agency. (1982b) Air quality criteria for particulate matter and sulfur oxides. Research Triangle Park, NC: Office of Health and Environmental Assessment, Environmental Criteria and Assessment Office; EPA report no. EPA-600/8-82-029aF-cF. 3v. Available from: NTIS, Springfield, VA; PB84-156777.
- U.S. Environmental Protection Agency. (1982c) Air quality criteria for particulate matter and sulfur oxides: v. 1, addendum Research Triangle Park, NC: Environmental Criteria and Assessment Office; pp. A1-A15; EPA report no. EPA-600/8-82-029aF. Available from: NTIS, Springfield, VA; PB84-156801/REB.
- U.S. Environmental Protection Agency. (1984a) Risk assessment and management: framework for decision making. Research Triangle Park, NC: Office of Health and Environmental Assessment, Environmental Criteria and Assessment Office; EPA report no. EPA 600/9-85-002. Available from: NTIS, Springfield, VA; PB85-170157/HSU.
- U.S. Environmental Protection Agency. (1984b) Revised evaluation of health effects associated with carbon monoxide exposure: an addendum to the 1979 EPA air quality criteria document for carbon monoxide. Research Triangle Park, NC: Office of Health and Environmental Assessment, Environmental Criteria and Assessment Office; EPA report no. EPA-600/8-83-033F. Available from: NTIS, Springfield, VA; PB85-103471/HSU.
- U.S. Environmental Protection Agency. (1984c) Review of the NAAQS for carbon monoxide: reassessment of scientific and technical information. Research Triangle Park, NC: Office of Air Quality Planning and Standards; EPA report no. EPA-450/5-84-004. Available from: NTIS, Springfield, VA; PB84-231315.
- U.S. Environmental Protection Agency. (1985) Mutagenicity and carcinogenicity assessment of 1,3-butadiene: final report. Washington, DC: Office of Health and Environmental Assessment, Carcinogen Assessment Group; EPA report no. EPA-600/8-85-004F. Available from: NTIS, Springfield, VA; PB86-125507/AS.

- U.S. Environmental Protection Agency. (1986a) Air quality criteria for lead. Research Triangle Park, NC: Office of Health and Environmental Assessment, Environmental Criteria and Assessment Office; EPA report no. EPA-600/8-83/028aF-dF. 4v. Available from: NTIS, Springfield, VA; PB87-142378.
- U.S. Environmental Protection Agency. (1986b) Lead effects on cardiovascular function, early development, and stature: an addendum to U.S. EPA air quality criteria for lead (1986). In: Air quality criteria for lead, v. 1. Research Triangle Park, NC: Office of Health and Environmental Assessment, Environmental Criteria and Assessment Office; pp. A1-A67; EPA report no. EPA-600/8-83-028aF. Available from: NTIS, Springfield, VA; PB87-142378.
- U.S. Environmental Protection Agency. (1986c) Second addendum to air quality criteria for particulate matter and sulfur oxides (1982): assessment of newly available health effects information. Research Triangle Park, NC: Office of Health and Environmental Assessment, Environmental Criteria and Assessment Office; EPA report no. EPA-600/8-86-020F. Available from: NTIS, Springfield, VA; PB87-176574.
- U.S. Environmental Protection Agency. (1986d) Air quality criteria for ozone and other photochemical oxidants. Research Triangle Park, NC: Office of Health and Environmental Assessment, Environmental Criteria and Assessment Office; EPA report nos. EPA-600/8-84-020aF-eF. 5v. Available from: NTIS, Springfield, VA; PB87-142949.
- U.S. Environmental Protection Agency. (1986e) Addendum to the health assessment document for tetrachloroethylene (perchloroethylene): updated carcinogenicity assessment for tetrachloroethylene (perchloroethylene, PERC, PCE) [external review draft]. Washington, DC: Office of Health and Environmental Assessment, Carcinogen Assessment Group; EPA report no. EPA/600/8-82/005FA. Available from: NTIS, Springfield, VA; PB86-174489.
- U.S. Environmental Protection Agency. (1987) The risk assessment guidelines of 1986. Washington, DC: Office of Health and Environmental Assessment; EPA report no. EPA/600/8-87/045. Available from: NTIS, Springfield, VA; PB88-123997/XAB.
- U.S. Environmental Protection Agency. (1988a) Recommendations for and documentation of biological values for use in risk assessment. Cincinnati, OH: Office of Health and Environmental Assessment, Environmental Criteria and Assessment Office; EPA report no. EPA-600/6-87-008. Available from: NTIS, Springfield, VA; PB88-179874.
- U.S. Environmental Protection Agency. (1988b) Reference physiological parameters in pharmacokinetic modeling. Washington, DC: Office of Health and Environmental Assessment, Exposure Assessment Group; EPA report no. EPA/600/6-88/004. Available from: NTIS, Springfield, VA; PB88-196019/AS.
- U.S. Environmental Protection Agency. (1988c) Applications of an exact NOAEL procedure for dichotomous data from animal experiments [final]. Cincinnati, OH: Office of Health and Environmental Assessment, Environmental Criteria and Assessment Office.
- U.S. Environmental Protection Agency. (1990) Occupational exposure limit data in relation to inhalation reference doses. Washington, DC: Office of Health and Environmental Assessment; prepared for the Risk Assessment Forum.
- U.S. Environmental Protection Agency. (1991) Air quality criteria for carbon monoxide. Research Triangle Park, NC: Office of Health and Environmental Assessment, Environmental Criteria and Assessment Office; report no. EPA/600/8-90/045F. Available from: NTIS, Springfield, VA; PB93-167492.

- U.S. Environmental Protection Agency. (1992) Summary of selected new information on effects of ozone on health and vegetation: supplement to 1986 air quality criteria for ozone and other photochemical oxidants. Research Triangle Park, NC: Office of Health and Environmental Assessment, Environmental Criteria and Assessment Office; EPA report no. EPA/600/8-88/105F. Available from: NTIS, Springfield, VA; PB92-235670.
- U.S. Environmental Protection Agency. (1993a) Air quality criteria for oxides of nitrogen. Research Triangle Park, NC: Office of Health and Environmental Assessment, Environmental Criteria and Assessment Office; EPA report no. EPA/600/8-91/049aF-cF. 3v.
- U.S. Environmental Protection Agency. (1993b) Air quality criteria for ozone and related photochemical oxidants [review draft]. Washington, DC: Office of Research and Development; EPA report nos. EPA/600/AP-93/004a-c. 3v.
- U.S. Food and Drug Administration. (1982) Toxicological principles for the safety assessment of direct food additives and color additives used in food. Washington, DC: U.S. Food and Drug Administration, Bureau of Foods.
- Ultman, J. S. (1988) Transport and uptake of inhaled gases. In: Watson, A. Y.; Bates, R. R.; Kennedy, D., eds. Air pollution, the automobile, and public health. Washington, DC: National Academy Press; pp. 323-366.
- Ultman, J. S. (1994) Dosimetry modeling: approaches and issues. *Inhal. Toxicol.* 6(suppl.): 59-71.
- Vanderslice, R. R.; Domin, B. A.; Carver, G. T.; Philpot, R. M. (1987) Species-dependent expression and induction of homologues of rabbit cytochrome P-450 isozyme 5 in liver and lung. *Mol. Pharmacol.* 31: 320-325.
- Vettorazzi, G. (1977) Safety factors and their application in the toxicological evaluation. In: Hunter, W. J.; Smeets, J. G. P. M., eds. The evaluation of toxicological data for the protection of public health: proceedings of the international colloquium; December 1976; Luxembourg, Sweden. Oxford, United Kingdom: Pergamon Press; pp. 207-223.
- Vettorazzi, G. (1980) Handbook of international food regulatory toxicology: v. I, evaluations. New York, NY: Spectrum Publications; pp. 66-68.
- Ward, R. C.; Travis, C. C.; Hetrick, D. M.; Andersen, M. E.; Gargas, M. L. (1988) Pharmacokinetics of tetrachloroethylene. *Toxicol. Appl. Pharmacol.* 93: 108-117.
- Weibel, E. R. (1963) Morphometry of the human lung. New York, NY: Academic Press Inc.
- Weibel, E. R. (1972) Morphometric estimation of pulmonary diffusion capacity: V. comparative morphometry of alveolar lungs. *Respir. Physiol.* 14: 26-43.
- Weill, C. S. (1972) Statistics vs safety factors and scientific judgement in the evaluation of safety for man. *Toxicol. Appl. Pharmacol.* 21: 454-463.
- Weil, C. S.; McCollister, D. D. (1963) Relationship between short- and long-term feeding studies in designing an effective toxicity test. *J. Agric. Food Chem.* 11: 486-491.
- Weil, C. S.; Woodside, M. D.; Bernard, J. R.; Carpenter, C. P. (1969) Relationship between single-peroral, one-week, and ninety-day rat feeding studies. *Toxicol. Appl. Pharmacol.* 14: 426-431.

- Weiß, M.; Sziegoleit, W.; Förster, W. (1977) Dependence of pharmacokinetic parameters on the body weight. *Int. J. Clin. Pharmacol. Biopharm.* 15: 572-575.
- Wen, C. P.; Tsai, S. P.; Gibson, R. L. (1983) Anatomy of the healthy worker effect: a critical review. *J. Occup. Med.* 25: 283-289.
- Willeke, K., ed. (1980) Generation of aerosols and facilities for exposure experiments. Ann Arbor, MI: Ann Arbor Science Publishers, Inc.
- Wolff, R. K.; Griffis, L. C.; Hobbs, C. H.; McClellan, R. O. (1982) Deposition and retention of 0.1 μm $^{67}\text{Ga}_2\text{O}_3$ aggregate aerosols in rats following whole body exposures. *Fundam. Appl. Toxicol.* 2: 195-200.
- Woodruff, T. J.; Bois, F. Y.; Auslander, D.; Spear, R. C. (1992) Structure and parameterization of pharmacokinetic models: their impact on model predictions. *Risk Anal.* 12: 189-201.
- Yeh, H. C.; Schum, G. M.; Duggan, M. T. (1979) Anatomic models of the tracheobronchial and pulmonary regions of the rat. *Anat. Rec.* 195: 483-492.
- Yost, G. S.; Buckpitt, A. R.; Roth, R. A.; McLemore, T. L. (1989) Mechanisms of lung injury by systemically administered chemicals. *Toxicol. Appl. Pharmacol.* 101: 179-195.
- Young, J. T. (1981) Histopathologic examination of the rat nasal cavity. *Fundam. Appl. Toxicol.* 1: 309-312.
- Yu, C. P.; Xu, G. B. (1987) Predictive models for deposition of inhaled diesel exhaust particles in humans and laboratory species. Cambridge, MA: Health Effects Institute; research report no. 10.
- Yu, C. P.; Yoon, K. J. (1990) Retention modeling of diesel exhaust particles in rats and humans. Amherst, NY: State University of New York at Buffalo (Health Effects Institute research report no. 40).
- Yu, C. P.; Diu, C. K.; Soong, T. T. (1981) Statistical analysis of aerosol deposition in nose and mouth. *Am. Ind. Hyg. Assoc. J.* 42: 726-733.
- Ziegler, D. M. (1980) Microsomal flavin-containing monooxygenase: oxygenation of nucleophilic nitrogen and sulfur compounds. In: Jakoby, W. B., ed. *Enzymatic basis of detoxication: v. 1.* New York, NY: Academic Press, Inc.; pp 201-227.
- Ziegler, D. M. (1988) Flavin-containing monooxygenases: catalytic mechanism and substrate specificities. *Drug Metab. Rev.* 19: 1-32
- Zielhuis, R. L.; van der Kreek, F. W. (1979) The use of a safety factor in setting health based permissible levels for occupational exposure. *Int. Arch. Occup. Environ. Health* 42: 191-201.

APPENDIX A

ALTERNATIVE APPROACHES TO THE ESTIMATION OF NO-OBSERVED-ADVERSE-EFFECT LEVELS

The inhalation reference concentration (RfC) approach based on a lowest-observed-adverse-effect level/no-observed-adverse-effect level (LOAEL/NOAEL) paradigm is consistent with current methods for estimating human health risks from exposure to threshold-acting toxicants in water or food, such as those established by the Food and Drug Administration (Kokoski, 1976), the National Research Council (1977, 1980), the World Health Organization, the Food and Agricultural Organization (Bigwood, 1973; Vettorazzi, 1977, 1980; Lu, 1983), and other approaches used by U.S. Environmental Protection Agency (Federal Register, 1980; Stara et al., 1981; Barnes and Dourson, 1988). To date, these methods have generally considered only chronic or lifetime exposure to individual chemicals based on the assumption that "lifetime" data in laboratory animals are directly applicable to lifetime human exposures. As our understanding of the exposure-dose-response continuum is refined and the temporal aspects of the pathogenesis mechanisms elucidated (see Section 4.3.2), dose-response benchmark estimates for health risk characterization may be able to address intermediate duration, periodic, and other exposure scenarios with greater accuracy.

These methods generally estimate a single, constant daily dose that is low enough to be considered "safe" or "acceptable" (referred to as an acceptable daily intake [ADI]) or without appreciable risk (RfC). A number of scientific problems with this approach have been long recognized (Krewski et al., 1984; Crump, 1984; Brown and Erdreich, 1989). The first problem is that this method does not readily account for the number of animals used to determine the appropriate NOAEL. As described in Section 4.2 on designation of effect levels, the NOAELs or LOAELs that serve as the critical data in the RfC approach can be based on statistically significant or biologically significant increases in the frequency or severity of adverse toxic effects. For example, NOAELs have been defined for quantal endpoints that have nonzero background incidences by choosing an experimental exposure

level that does not contribute to a statistically significant increase in incidence of adverse effects when compared to a control group. Some NOAELs have been defined for continuous data by choosing an experimental exposure level that does not constitute a significantly different mean value for a parameter, indicating an adverse effect when compared to a mean value for a control group. Statistical significance, however, depends heavily on the design of the experiment, including sample size, the number of concentrations used, the spacing of the concentrations, and the arbitrary alpha level. Often the only information gained from the experiment used as the critical study is the presence or absence of statistical significance for an arbitrary alpha level at a small number of concentrations. Similarly, biological significance is often attributed to a concentration with little consideration of the impact of experimental design and no strict definition of the biological changes, suggesting that the designation of NOAEL or LOAEL is to an extent subjective. For example, if a chemical has a NOAEL based on 10 animals and another NOAEL with the same value but based on 100 animals, the risk assessor often will choose the NOAEL based on the larger study because it yields greater confidence in the resulting RfC. However, comparison of statistical power is not routinely done and the influence of sample size may not be taken into account when comparing disparate NOAELs. It has also been argued that the use of this approach encourages studies with smaller sample sizes, which reduce the power of the test. If these NOAELs were for different chemicals, similar RfCs might be derived, even though one would be associated with much less confidence.

The second problem with the current NOAEL/LOAEL approach is that the slope of the dose-response curve of the critical toxic effect is generally ignored in the estimation of the NOAEL. Many scientists have argued that this slope should in some way directly affect the estimate, with steep curves presumably yielding lower values because thresholds or greater toxicities are more quickly obtained with increasing concentration.

Furthermore, the current NOAEL/LOAEL approach to noncancer dose-response assessment yields an RfC estimate that is presented as a single number. As such, it reflects neither the statistical variability in the NOAEL resulting from study design factors nor the inherent variability for which uncertainty factors are applied to extrapolate from the data base to the RfC. The result of this variability is the unknown range of uncertainty in the estimate. Exposure estimates to which the dose-response estimate must be compared are also associated

with a range of uncertainty and many exposure models now express explicitly this variability as a distribution. Risk management decisions for regulation or enforcement need more quantitative information on the inherent and recognized uncertainties in this assessment.

This appendix defines and illustrates alternative approaches to derivation of estimates that could be used as analogues to the NOAEL. Many of these approaches offer solutions to some of the criticisms of the NOAEL/LOAEL approach outlined above and these attributes will be highlighted. Even so, no method is without inherent problems. Guidance is under development that describes the application of "benchmark" concentration-response modeling (Section A.2) to derive dose-response estimates such as the inhalation RfC. Recently, EPA and the Risk Science Institute of the International Life Sciences Institute (ILSI) sponsored a workshop entitled, "Workshop on Benchmark Dose Methodology". A summary paper from the deliberations at these meetings discusses definitions and criteria for the use of a benchmark approach to estimate a reference dose or reference concentration (Barnes et al., 1994). The Risk Assessment Forum is also working on guidance that is anticipated to be published as a "purple book". The reader is referred to these additional sources and is encouraged to appreciate that development of guidance awaits consensus on issues raised both herein and in these additional materials.

It is worthwhile to emphasize, as it will be noted in subsequent sections of this appendix, that the toxicological decision as to what constitutes adversity (i.e., the decision that a specified effect is adverse and what the associated severity is), particularly across different endpoints, remains perhaps the most sensitive parameter in any of these procedures regardless of the mathematical model applied. Using quantal data, for example, it is a decision based on toxicological judgment that determines whether 10% or 30% incidence of a given lesion should be a concern. Similarly, toxicological or clinical insight may be required to determine if a particular change in a continuous parameter (e.g., pulmonary function decrement) is adverse relative to a normal population value or between a control and an exposed cohort. To date, there has not been adequate appreciation by toxicologists and biostatisticians alike of the interdependence of the decision to designate an effect as biologically significant and the decision to estimate a response at a given level from the mathematical model. Perhaps awareness of the interdependence is the single most important factor that requires systematic development before any of these approaches can be

implemented consistently. The decision on the definition of adversity or biological significance is termed designation of the "specified health effect" for purposes of discussion in this appendix. The concept of a specified health effect is not new and is related to the concept of "relative potency" (Jarabek and Hasselblad, 1991). Finney (1978) defines a relative potency in his description of a direct assay. A direct assay is one in which "...doses of the standard and test preparations sufficient to produce a specified response are directly measured. The ratio between these doses estimates the potency of the test preparation relative to the standard...." Note that the choice of a "specified response" is key to the definition.

Because all of the approaches presented herein have not yet been applied routinely to the types of data generally encountered when evaluating the health effects information available on the majority of inhaled chemicals, aspects that require further development and consideration in order to use these alternatives will also be presented.

A.1 NO-STATISTICAL-SIGNIFICANCE OF TREND (NOSTASOT)

A statistically more accurate approach than the traditional NOAEL/LOAEL for estimating a NOAEL when several exposure levels are available is the "no statistical significance of trend" (NOSTASOT) approach proposed by Tukey et al. (1985). The underlying principle is to sequentially test for a linear trend until significance is no longer reached. As described by Tukey et al. (1985), the procedure is applied to all of the data first and then entails sequentially deleting the highest exposure groups in succession downward (i.e., "top-down" analysis). In this manner, the highest exposure level at which the response is not significantly different from controls is determined to be the NOSTASOT, which could therefore be considered a NOAEL.

A.1.1 Approach Advantages

The advantage of the NOSTASOT approach is that it offers a simple yet fairly robust method to determine a NOAEL by testing for a trend in all exposure levels (including controls). As such, it utilizes more of the concentration-response information than individual comparisons of exposed and control groups.

A.1.2 Application Issues and Development Needs

As proposed by Tukey et al. (1985), the NOSTASOT procedure tests for a statistical significant trend in a series of exposure levels (including controls) until the highest level at which the trend is nonsignificant is reached. This highest level is defined as the NOSTASOT exposure and would be used as a surrogate to the NOAEL in derivation of an RfC. The last concentration at which statistical significance was achieved would be a LOAEL. The method was developed for application to data from experiments involving multiple groups of animals of approximately the same size at different dose/exposure levels, including a zero-dose control. In such cases, the NOSTASOT method may be preferred because it includes more information and may have greater statistical power than multiple comparisons of different experimental groups to a control group. However, despite its robustness, the NOSTASOT approach remains sensitive to dose spacing. It is also sensitive to sample size when applied to grouped data. Application to epidemiologic data with individual exposure data or to continuous response measures is not straightforward.

An alternative to the NOSTASOT approach is to start at the lowest noncontrol exposure or dose level and move upward (i.e., "bottom-up" analysis). The objective is to determine the highest level of nonsignificance before a significant difference is detected. The highest nonsignificant dose would be declared the NOAEL and the first statistically significant dose a LOAEL in this analysis. The sensitivity to sample size and dose spacing of the NOSTASOT approach is illustrated by the difference between a "top-down" versus "bottom-up" analysis. In most animal experiments for which the procedure was developed, with groups of the same size exposed to typically only at one, two, three, or four levels, the NOSTASOT would be the same whether analyzed from the top down or the bottom up, assuming that the response is monotonic. However, in data sets with a large number of exposure levels or with individual exposure data, the top-down and bottom-up analyses may yield very different estimates (i.e., a LOAEL from the bottom-up analysis may be below a NOAEL from the top-down analysis). This is conceivable with some nonlinear and/or nonmonotonic data sets (Davis and Svendsgaard, 1990). It is therefore necessary to apply the method in a manner that recognizes possible nonlinearities in the data (e.g., due to a sensitive subpopulation responding at low concentrations). Such complications warrant consideration when applying the NOSTASOT approach.

A.2 "BENCHMARK" CONCENTRATION-RESPONSE MODELING

Concentration-response modeling, recently referred to as the "benchmark dose" approach, has been proposed as an improvement on the NOAEL/LOAEL approach (Crump, 1984). The "benchmark" approach, as defined in this discussion, is the use of a specific mathematical model (e.g., Weibull, logistic, polynomial) to determine a concentration (applied dose) and its lower confidence bound that is associated with a predefined effect measure (e.g., 10% response of a dichotomous outcome) as the "benchmark". Application of this approach (Kimmel and Gaylor, 1988) has been proposed for developmental endpoints, which are generally dichotomous (quantal) in nature, but it has yet to be applied widely to other noncancer outcomes.

Figure A-1 illustrates the benchmark approach as applied to laboratory animal developmental data. A mathematical model (e.g., Weibull, logistic, polynomial) is applied (fitted) to the experimental effects data to estimate a maximum likelihood estimate (MLE) or concentration-response function. The 95% confidence limit is calculated using information on sample size and variance. It has been recommended that limits based upon the distribution of the likelihood ratio statistic be used as the method of choice for this calculation (Crump, 1984). The possible analogues to a NOAEL can then be estimated. For example, the 10th percentile of an effect level could be designated as synonymous to "no adversity" and the concentration corresponding to the MLE of that effect level used as the "effective concentration" (EC_{10}). The lower confidence bound on the EC_{10} could also be used and is shown as " LEC_{10} ". A linear interpolation has also been proposed (Gaylor and Kodell, 1980; Kimmel and Gaylor, 1988) that allows estimation of upper limits on risk for convex dose-response curves. For example, as shown in Figure A-1, at a dose of LEC_{10} divided by an uncertainty factor (UF), the "true" unknown risk in the low-dose regions is expected to be less than that associated with the linear extrapolation if the "true" dose-response curves upward.

A.2.1 Approach Advantages

Compared to the NOAEL/LOAEL approach, benchmark concentration-response modeling has the advantages that it utilizes more information from the dose-response curve, is less influenced by experimental design (e.g., exposure level spacing), and is sensitive to the

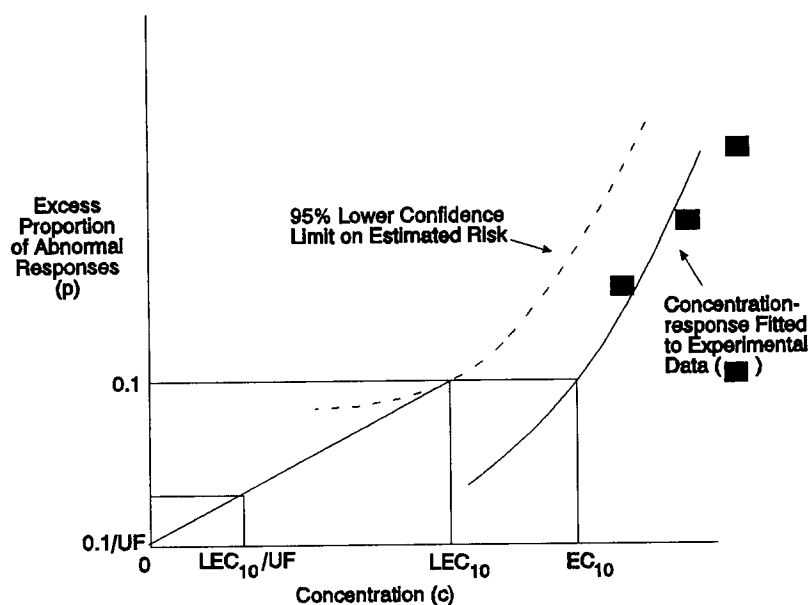

Figure A-1. Graphical illustration of proposed low-dose risk estimation for the proportion of abnormal responses in developmental toxicity.

Adapted from Kimmel and Gaylor (1988).

influence of sample size. It is important to note that this approach is sensitive to sample size only when the "benchmark" is defined as the lower confidence bound. The MLE alone is not influenced by sample size.

A.2.2 Application Issues and Development Needs

Application of this approach to the myriad of endpoints that can constitute noncancer toxicity will require significantly greater effort directed at modeling continuous data. A limitation may be finding data sets appropriate for modeling. Guidance must be developed on choice of model structures and on goodness-of-fit criteria for models, especially whether or not it is appropriate to superimpose model structures on data that only have one dose group associated with a nonzero response (relative to control or background). Whether or not there is a biological basis (e.g, for certain endpoints) for selecting certain model structures also warrants investigation.

Use of the benchmark approach still requires dosimetric adjustment to a human equivalent concentration (Section 4.3) and for application of UFs to account for extrapolations (Section 4.3.8.1). Dosimetric adjustment to account for interspecies differences should be applied before the data are modeled.

Application of UFs in a fashion analogous to that used with the NOAEL/LOAEL paradigm have been proposed for use with the benchmark approach (Dourson et al., 1985, 1986). That is, a benchmark estimate for a more severe endpoint (e.g., liver necrosis), essentially equivalent to a LOAEL, would warrant application of an additional UF, whereas the endpoint judged as less severe (e.g., slight body weight decrease) would not. Application of UF for intraspecies variability, subchronic duration, and data base may also be appropriate.

Another approach for the application of UFs for dichotomous data has been proposed using the linear interpolation from the LEC_{10} through the origin as shown in Figure A-1 (Kimmel and Gaylor, 1988). As shown on Figure A-1, if UF represents an uncertainty factor, then the true unknown risk at an exposure concentration of LEC_{10}/UF is expected to be less than $0.1/UF$. This procedure is conservative with respect to risk when the dose-response is convex (curving upward). Therefore, an advantage is that an upper limit on the risk is estimated. The size of the factor depends on the desired level of risk. For example, a factor of 10 applied to the LEC_{10} would result in a risk less than 10^{-2} . This approach assumes that the incidence in humans on which the "acceptable risk" decision is based is equivalent to the observed incidence of a given lesion in the experimental animals. An equivalent procedure for continuous data would necessitate an assumption that the mean severity or magnitude of the observed effect in the exposed population relative to the control (or relative to a normal reference) was equivalent in experimental animals and humans.

These UF approaches essentially result in subthreshold estimates, similar in intent to the RfC, provided the LEC_{10} is considered to be analogous to a NOAEL and if the designation of the specified health effect is unequivocal. However, the designation of a specified health effect is a question of both biological and statistical significance. Various levels (e.g., EC_{01} , EC_{05} , and EC_{10}) have been proposed that could be considered as a NOAEL criterion

(Gaylor, 1983; Kimmel and Gaylor, 1988; Fabro et al., 1982).¹ If one incidence level were to be designated as the NOAEL criterion (e.g., 10%), a dose-response estimate could be based on either 10% nasal hyperplasia or 10% proximal tubule necrosis, unless the severity of the endpoint is taken into account. Intimate knowledge of the spectrum of severity within a pathogenesis continuum for an individual endpoint may be required before criteria can be established for designating specified health effects. Further, in order to compare across the various endpoints associated with noncancer toxicity, it may be necessary to "normalize" (e.g., designate the 50th percentile as the criterion for a minimally adverse effect and the 1st percentile for a severe effect), but this would require consensus on definitions of severity. The interaction with model structure may also be influenced by these criteria. For example, model "fit" and variability in the resultant estimate would be different for lesions designated at the EC₅₀ and the EC₀₁ and determined at the associated lower confidence bound. The relationship of these different estimates to applied UFs would also be different. The choice of the mathematical model structure generally makes relatively little difference down to approximately the 1% risk level. Estimation of excess risk above background in the region below that level can become more dependent on the choice of model structure than on the true dose-response curve. Although previous use of the "benchmark" approach avoided this controversy because developmental endpoints do not distinguish degrees of severity to a large extent, such issues are critical for development of this approach as an application to all the other common noncancer endpoints.

Derivation of a dose-response estimate by the benchmark approach also does not preclude evaluation of the data base for completeness. A comprehensive array of endpoints must be evaluated to identify potential hazard for various target tissues regardless of the way individual endpoints may be modeled. Once the individual specified health effects are decided, determinations of the appropriate species and critical effect representative of the threshold for the overall data array must be evaluated as described for the RfC methodology in Section 4.3.7.

¹It could also be argued that the exposure estimated to be the 5th percentile is really a lower confidence limit of the exposure causing a specified effect. In that sense, any point below it is associated with no effect, and therefore the 5th percentile (or any other lower tail percentile) could be considered as a NOAEL. Designation criteria for the LOAEL, however, will be problematic as outlined above.

A.3 APPLICATION OF BAYESIAN STATISTICS

As discussed in Section 4.3.7, the analysis of noncancer toxicity data often involves evaluation of data and a synthesis of information together in order to determine a representative level for the threshold region of the data array. For example, sometimes a NOAEL from one study may be used in conjunction with a NOAEL from another. Data from a "free-standing" NOAEL are often used in a qualitative sense but cannot be used in a dose-response model. The advantage to such a synthesis is the utilization of more information rather than the reduction of data to a single study and its effect level, a practice that is recognized as a significant limitation to the RfC and benchmark approaches described above.

A Bayesian statistical approach has been proposed that both statistically incorporates the attributes of the benchmark approach (incorporates influence of sample size and shape of the dose-response curve) as well as offers the advantages of (1) visual display and description of the uncertainty in the risk estimates, (2) allows for explicit synthesis of dose-response estimates together when determined appropriate, and (3) allows for explicit incorporation of uncertainty in the exposure characterization (Jarabek and Hasselblad, 1991; Hasselblad and Jarabek, 1994).

The general approach proposed has been published under the title of the Confidence Profile Method (Eddy et al., 1992). It combines the standard classical and Bayesian statistical methods to produce likelihood functions and posterior distributions for parameters of interest. Although the likelihood functions and posterior distributions have very different interpretations, their shape is usually extremely similar. The likelihood function can be used to compute confidence intervals. The posterior distribution is a continuous plot describing belief about the location of the parameter of interest (i.e., for dose-response estimation purposes, about the dose associated with a specified health effect). The basic formula of Bayesian statistics is

$$p'(\theta) = L(\theta | \text{data}) p(\theta), \quad (\text{A-1})$$

where:

θ = parameter of interest,
 $p(\theta)$ = prior distribution for θ ,
 $L(\theta | \text{data})$ = likelihood for θ given new data, and
 $p'(\theta)$ = posterior distribution for θ . Because $p'(\theta)$ will become the prior for the next experiment, it is denoted by the same letter.

Consider the following simple example of a continuous effect measure. Assume that the health effect, y , is related to the exposure, x , given by the model

$$y = \beta x. \quad (\text{A-2})$$

Assume further that we wish to specify a particular health effect, y_0 , and then estimate the exposure corresponding to this effect as

$$\theta = y_0/\beta. \quad (\text{A-3})$$

Because θ is not defined for $\beta \leq 0$, it is reasonable to choose the prior for θ as $p(\beta) = 1$ for $\beta > 0$ and $p(\beta) = 0$ elsewhere. This corresponds to the belief that exposure to a toxic chemical is not beneficial. The prior just described is the horizontal dashed line in Figure A-2. Assume that an experiment to determine information about β was conducted, resulting in the likelihood, $L(\beta)$, shown as a dotted line in Figure A-2. Note that this likelihood is positive for values of β less than 0. The posterior distribution, $p'(\beta)$, is the product of the likelihood function and the prior (properly normalized to be a probability distribution) and is shown as a solid line in Figure A-2. Note that this distribution has the same general shape as the likelihood function, except that it has no mass below zero. This kind of distribution is often referred to as a truncated distribution. The posterior distribution of θ can be calculated from the posterior distribution of β . It should be emphasized that the mathematical modeling of these data was not different for these effect measures than that which could be achieved using a benchmark approach, but the expression as a normalized posterior distribution is the difference that provides for visual inspection and statistical combination of data. The posterior distribution, $p'(\beta)$, can be used as a prior if another experiment is conducted giving additional information about β , and the application of Bayes'

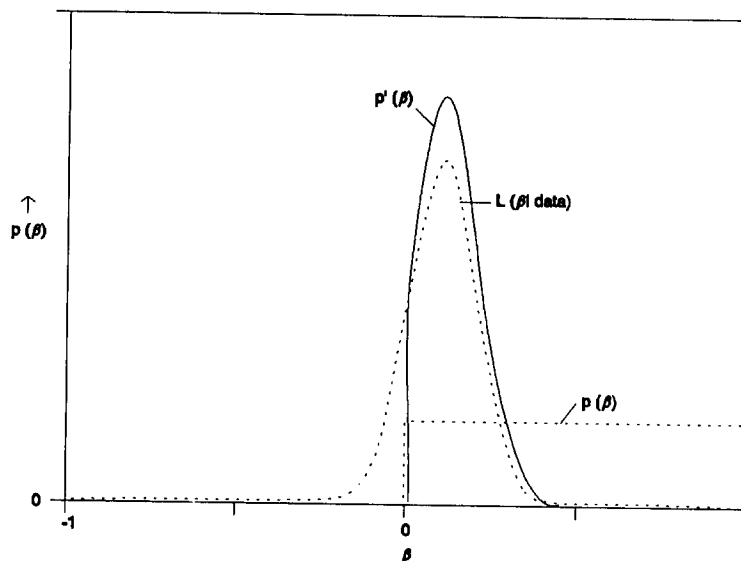

Figure A-2. Schematic of computing a posterior distribution $[p'(\beta^C)]$ from a likelihood function $[L(\beta | \text{data})]$ and a prior distribution $[p(\beta)]$.

Source: Jarabek and Hasselblad (1991).

formula repeated. (Note: In the following applications, θ [the parameter of interest] is designated as x_0 , the exposure concentration associated with a specified health effect.)

The proposed Bayesian approach is illustrated in Figures A-3 through A-5. Figure A-3 shows the dose-response from a logistic model superimposed on the dichotomous data for nasal turbinate lesions in mice exposed to *n*-hexane (data of Dunnick et al., 1989). For illustration purposes, an incidence of 10% (shown by the dashed line) is designated as the specified health effect (Jarabek and Hasselblad, 1991). Figure A-4 shows the posterior distribution for the *n*-hexane concentration associated with that 10% incidence. Figure A-5 shows the statistical synthesis together of posterior distributions of two different concentrations associated with specified health effects (one respiratory, the other neurotoxicity) of two studies (Dunnick et al., 1989; Sanagi et al., 1980.) The results of this synthesis were in general agreement with the NOAEL used for the RfC derivation for this chemical (IRIS, 1990) and with the benchmark approach for either of the two studies (data not shown). Although experimental details are provided elsewhere (Jarabek and Hasselblad, 1991), the two data sets represent both continuous and dichotomous effect measures, illustrating the ability of the Bayesian approach to address different outcomes.

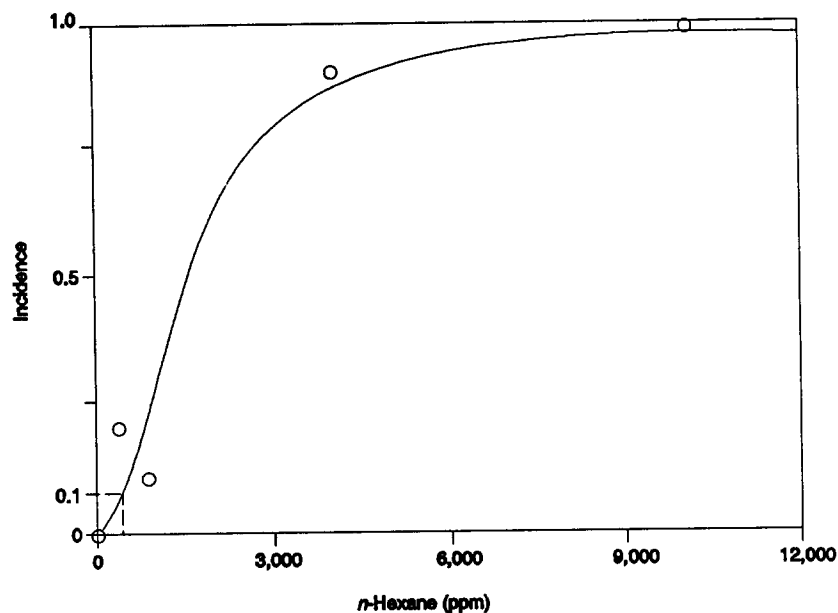

Figure A-3. Incidence of nasal turbinate lesions in B6C3F1 female mice exposed to *n*-hexane for 13 weeks. Data of Dunnick et al. (1989).

Source: Jarabek and Hasselblad (1991).

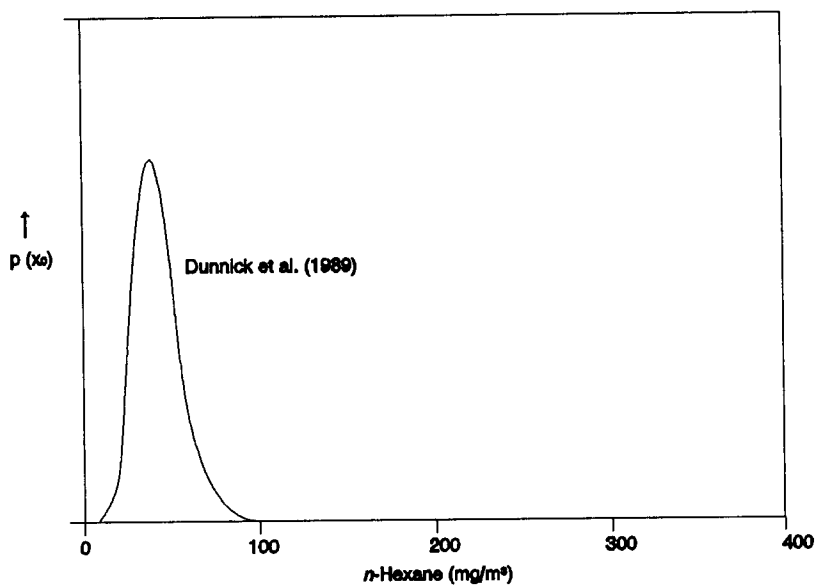

Figure A-4. Posterior distribution for the *n*-hexane concentration associated with the specified health effect in Figure A-3. Data of Dunnick et al. (1989).

Source: Jarabek and Hasselblad (1991).

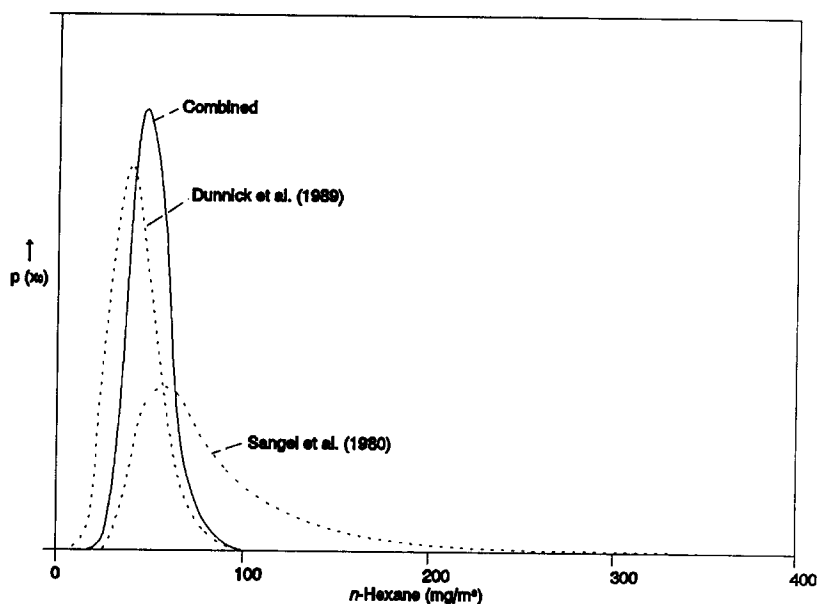

Figure A-5. Posterior distribution for the concentration of *n*-hexane associated with the specified health effects from the combined evidence of Sanagi et al. (1980) and Dunnick et al. (1989).

Source: Jarabek and Hasselblad (1991).

A.3.1 Approach Advantages

Visual presentation of data is a powerful tool for analysis and communication (Cleveland, 1985). Visual inspection of the posterior distribution concurs with the variability of the data and provides much information about the usefulness of the health effects data for dose-response evaluation. The shape of the posterior distribution for the data of Dunnick et al. (1989), in contrast to that of Sanagi et al. (1980), easily highlights that these data were generated from an investigation with an adequate number of animals and test concentrations with a resultant tighter distribution and reduced variance. The skewed posterior distribution for the data of Sanagi et al. (1980) results from its greater variance and small sample size. The value of visual presentation is again illustrated in Figure A-6. This figure shows the posterior distributions for the concentration of manganese (Mn) associated with specified health effects (all approximately the same measure of neurotoxicity) from three different studies. The visual presentation of the posterior distribution easily communicates that the data of Chandra et al. (1981) were highly variable and in fact do not add much information

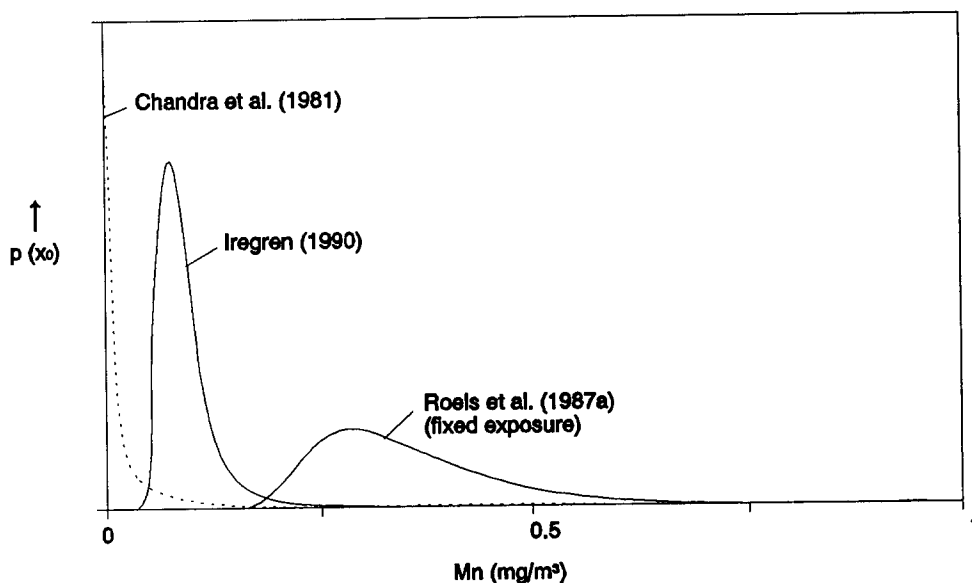

Figure A-6. Posterior distributions for the manganese (Mn) concentration associated with specified health effects from each of three studies: Roels et al. (1987a), Iregrén (1990), and Chandra et al. (1981).

to the synthesis. An appreciation of this variability would not have been imparted from the numeric reporting of the estimate alone. Even if the percentile values were reported and some sort of analysis on the spread is done (e.g., compare the ratio of the 95th to 50th percentile for all studies), the communication of the reliability of these data is not as straightforward as that of the visual display.

The Bayesian approach also allows for explicit incorporation of uncertainty in the exposure estimates of the studies being evaluated. The influence that direct application of uncertainty in the exposure estimate can have on the resultant dose-response estimate is illustrated in Figures A-7 through A-9. These figures illustrate the influence of variability in exposure characterization for the health effect data used to determine the dose-response. Because the posterior distribution now expresses the dose-response estimate as a distribution instead of a point estimate, this approach allows the dose-response distribution to be combined statistically with an exposure distribution for risk characterization. Therefore, such

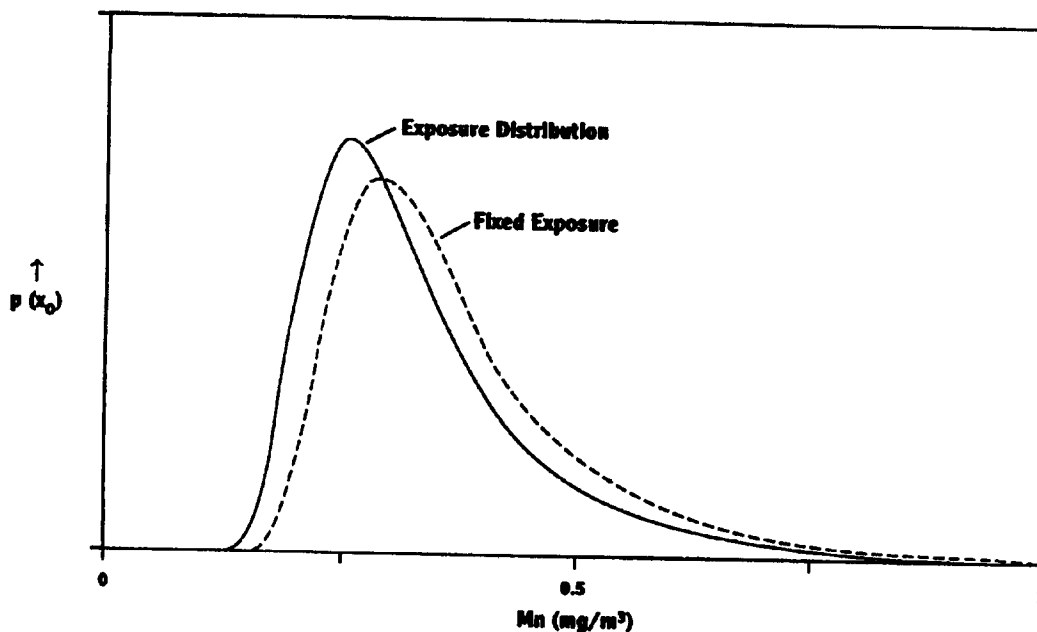

Figure A-7. Posterior distribution for the manganese (Mn) concentration associated with specified health effect using either exposure or estimated exposure distribution. Data Roels et al. (1987a,b).

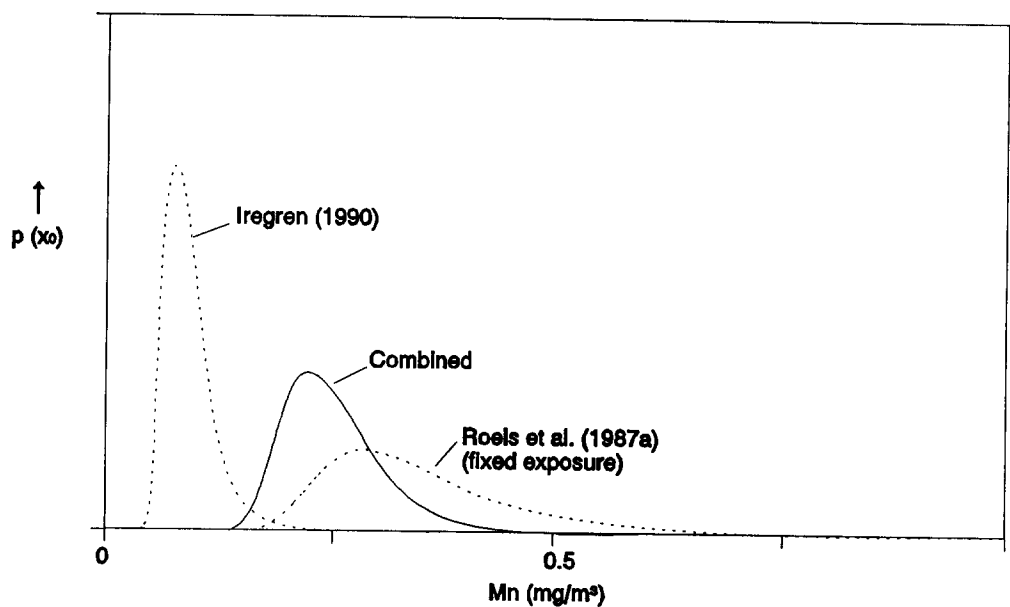

Figure A-8. Posterior distribution for the concentration of manganese (Mn) associated with specified health effect from the combined evidence of Iregren (1990) and Roels et al. (1987a) with fixed exposure.

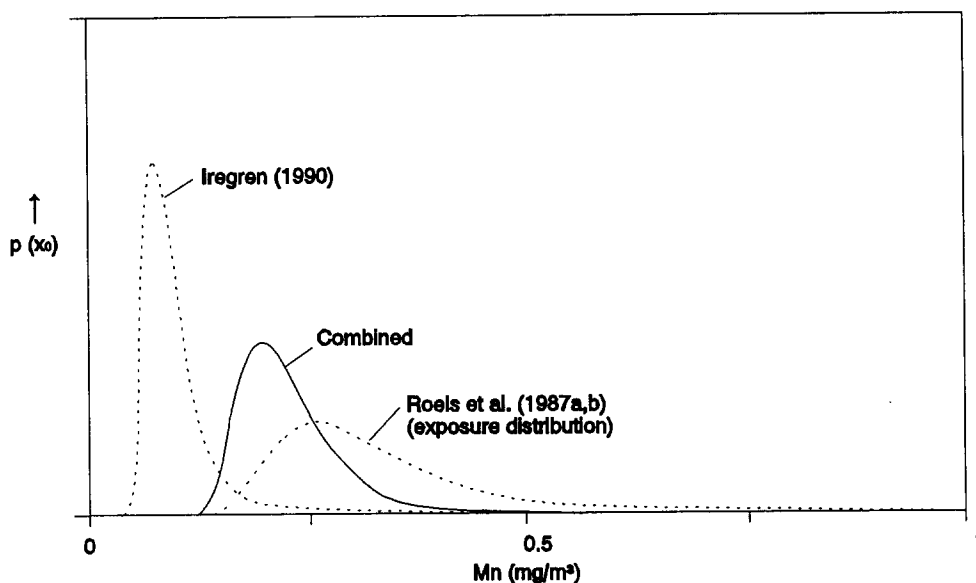

Figure A-9. Posterior distribution for the concentration of manganese (Mn) associated with specified health effect from the combined evidence of Iregren (1990) and Roels et al. (1987a,b) with exposure distribution.

presentation will allow explicit incorporation of uncertainty in the dose-response and exposure estimate to be carried through to the risk characterization step and could provide more information on which to base management decisions.

The Bayesian approach offers the advantages of the benchmark approach in that it takes into account the influence of sample size and shape of the dose-response curve. However, it is the only currently viable approach that offers the ability to statistically combine evidence from different investigations. Such synthesis is routinely done with data without explicit statistical handling of experimental design.

The Bayesian approach offers the advantages of the benchmark approach in that it takes into account the influence of sample size and shape of the dose-response curve. However, it is the only approach that offers the ability to statistically combine evidence from different investigations. Such synthesis is routinely done with data without explicit statistical handling of experimental design.

A.3.2 Application Issues and Development Needs

As mentioned, the Bayesian approach is essentially the same method as the benchmark approach up until the expression of the posterior distribution. Therefore, most of the issues under Section A.1.2 apply to the development of this approach as well.

In addition, application of the statistical synthesis capability of the approach will require guidance development as well. Figure A-3 presents the statistical combination of data with different endpoints: neurotoxicity (Sanagi et al., 1980) and respiratory tract effects (Dunnick et al., 1989). The resultant posterior distribution for the combined evidence of different endpoints was not drastically different relative to the individual distributions from which it was derived. This may be due to the fact that both studies investigated very sensitive endpoints (i.e., near the threshold or subthreshold region). Perhaps when data are not comparable with respect to assayed endpoints, but the data represent very sensitive endpoints, then the combination of these data provide a more likely estimate of the concentration of concern. The data combined for Mn on the other hand, were all for the same specified health effect (neurotoxicity). The exclusion of the Chandra et al. (1981) data was on the basis of statistical considerations. Future development of this approach will have to develop guidance on limitations for data combination both for statistical and biologically motivated concerns.

A.4 CATEGORICAL REGRESSION: USE OF DOSE-GRADED DATA

Not all data are expressed as quantal or continuous data that are readily amenable to available standard dose-response models. Results are often reported as "categorical" (i.e., descriptive or severity-graded results [e.g., a particular dose group exhibited "mild" toxicity]). As mentioned in the advantages for the Bayesian approach, other studies that are not explicitly designed to examine dose-response relationships, such as single-dose studies or mechanistic studies, may nonetheless provide useful data that should be incorporated into the data array analysis.

An analysis method that allows the combination of quantal data with categorical data and models the relationship between the severity of the effect against the exposure concentration and duration has been proposed for chronic oral toxicological data

(Hertzberg, 1989). Guth et al. (1991, 1993) have extended this work to inhalation exposures and have proposed a regression analysis method that provides for incorporation of both quantal and dose-graded data and for data across different durations. The method has been proposed in order to utilize as much of the available data as possible for the evaluation of short-term inhalation exposures defined as less than or equal to 24 h in duration.

A categorization scheme is used for the quantitative exposure-severity analysis, with severity category as the dependent variable and with concentration and exposure duration as independent variables. The severity scheme consists of three categories representing NOAELs, adverse effect levels (AELs), and lethality. More complicated severity-ranking schemes can be applied but become contentious due to the difficulty in equating severity of effect measures across target organs, endpoints, and species (Guth et al., 1991; 1993).

The form of the model for regression analysis is

$$\text{LN}(p/1 - p) = A_i + B_1\text{LN}(\text{Concentration}) + B_2(\text{Duration}), \quad (\text{A-4})$$

where p is the probability that, at a given concentration and duration of exposure, severity will be less than or equal to the severity category with rank = i , and A and B are estimated model parameters. The model is solved for $P = 1 - p$, or the probability that, at a given concentration and duration, the severity will be greater than the severity category with rank = i . The regression analysis assumes constant slope parameters, hence the values of B_1 and B_2 are constant across severity categories. The order or rank of the categories is used, rather than the numerical values.

The model output is readily interpreted in the context of risk assessment. Figure A-10 illustrates the method applied to categorical data for exposures of less than 8 h in duration and shown as NOAELs, AELs, or lethality. Although longer exposure regimens are appropriate as an alternate method to derive a NOAEL for the RfC, this example based on acute data is offered. The maximum likelihood model fit is shown by the line representing the model prediction of $p = 0.1$ that severity is greater than the NOAEL category (i.e., that the predicted effect would be in the "adverse" range or higher) at the corresponding exposure concentration and duration.

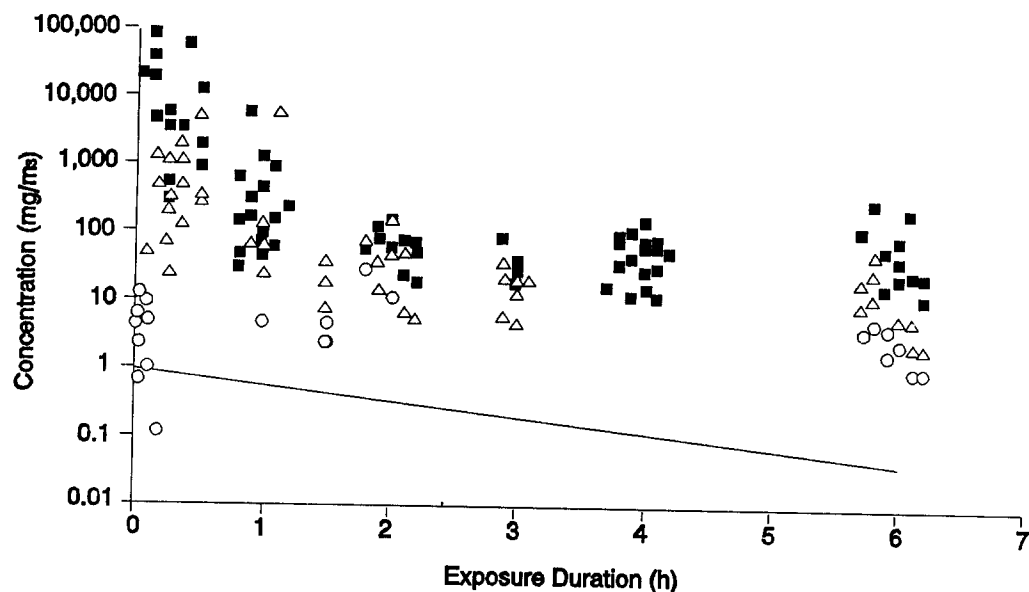

Figure A-10. Categorical data from published results on methyl isocyanate for exposures of less than 8 h in duration and shown as NOAEL (circles), AEL (triangles), or lethality (squares). The maximum likelihood model fit is shown by the line representing the model prediction ($p = 0.1$) that severity is greater than the NOAEL category at the corresponding exposure concentration and duration.

Source: Guth et al. (1993).

A.4.1 Approach Advantages

Health risk assessments generally require evaluation of several types of toxicity data derived from several different species, different doses, different exposure durations, varied endpoints, and varied quality. This variety often makes the health risk assessment extremely difficult. Therefore, it is valuable to have all such toxicity data displayed simultaneously and this approach offers the advantage of a graphic presentation. Exposure-duration response trends, if present, are clearly delineated. This insight may provide a possible strategy for disaggregation of data according to a duration window and/or for a particular endpoint.

This categorical analysis approach also offers the advantages of allowing the use of data that is not otherwise amenable to quantitative concentration-response analysis, such as categorical data and data from single-dose studies, and of incorporating both concentration and duration of exposure as explanatory variables. Various types of data (dichotomous,

continuous, categorical) can be considered simultaneously by converting each to a categorical descriptor. The estimates from this approach applied to short-term data have been shown to be in general agreement with estimates obtained from both the benchmark and NOAEL/LOAEL approaches (Guth et al., 1991; Guth et al., 1993).

The approach also offers the advantage of providing estimates for a range of exposure durations. Interpolation along this NOAEL boundary can be performed to estimate the NOAEL for any desired partial-lifetime exposure, rather than a linear prorate of the point estimate value at one given duration as is currently done with many approaches. It should be noted again that although the data shown here are truncated to exposures of less than 24-h duration, data can be incorporated for any duration and have been applied to the entire data sets on chemicals, regardless of duration (Dourson et al., 1986).

A.4.2 Application Issues and Development

Development of this approach requires guidance on model application, particularly minimum data base requirements. For example, if data are too sparse or when the effect levels are far apart, often the model will not converge. Figure A-11 shows the model fit to the same data as in Figure A-10 but with the exclusion of lethality data. The presence of the lethality data influences how the model addresses the boundary line between "adverse" and "no-adverse" levels. It is also a question as to whether lethality data are appropriate to use for dose-response assessment that intends to be protective of public health. When the data are on one type of specified health effect (e.g., 2% carboxyhemoglobin in blood) in a single species (humans), the model shows remarkable agreement with estimates generated by a PBPK model for the same specified effect (Figure A-12). When an array of different endpoints are available from a number of different species, as shown in Figure A-13, then the choice of an endpoint may not be as straightforward. Therefore, the biological rationale for model application also needs to be refined, especially on whether to aggregate or disaggregate data on individual endpoints. If disaggregation results in convergence failure, then it could be argued that this approach using all the available data provides a conservative estimate of a NOAEL boundary and may be more certain than one derived from a single study. One approach to disaggregation of data may be based on respiratory versus extrarrespiratory effects (and perhaps segregation of extrarrespiratory endpoints) because it is likely that different

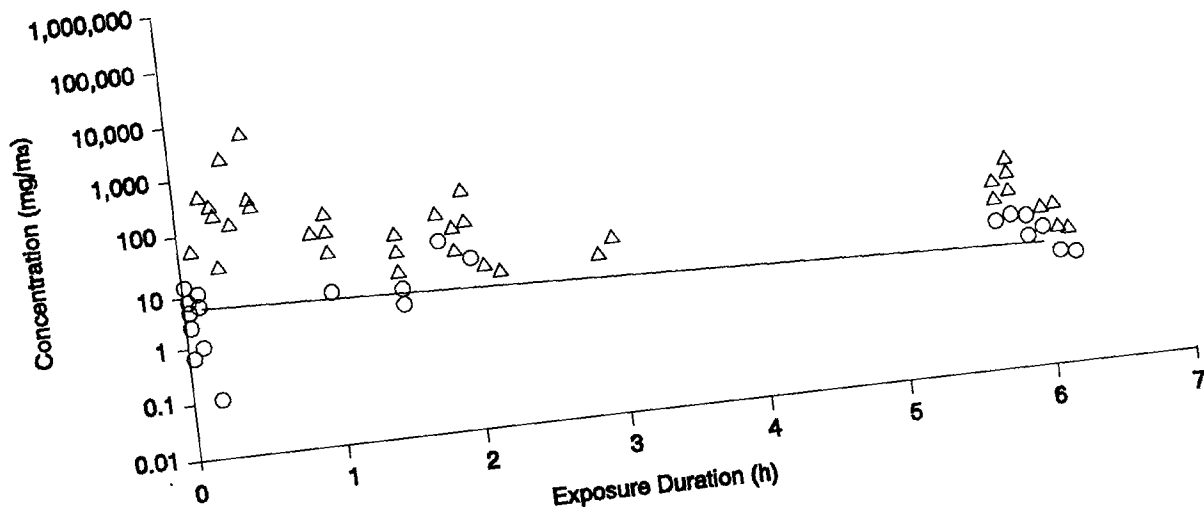

Figure A-11. Categorical data from published results as in Figure A-10, excluding lethality data.

Source: Guth et al. (1993).

Dichloromethane, Human COHb

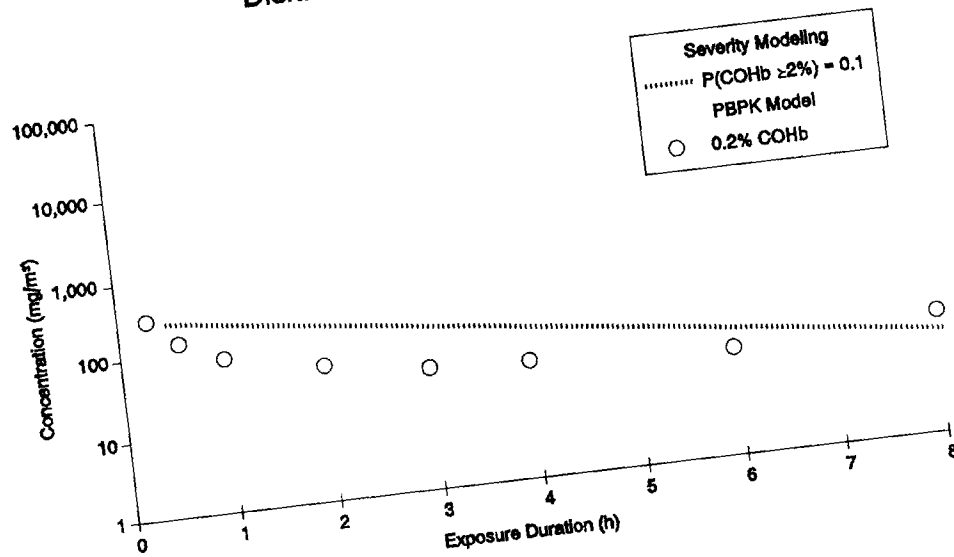

Figure A-12. Categorical regression analysis for data on carboxyhemoglobin (CoHb) in humans. Specified adverse health effect was 0.2% CoHb. Circles indicate PBPK model estimates (Andersen et al., 1991) to achieve same 0.2% CoHb at various concentration and duration combinations.

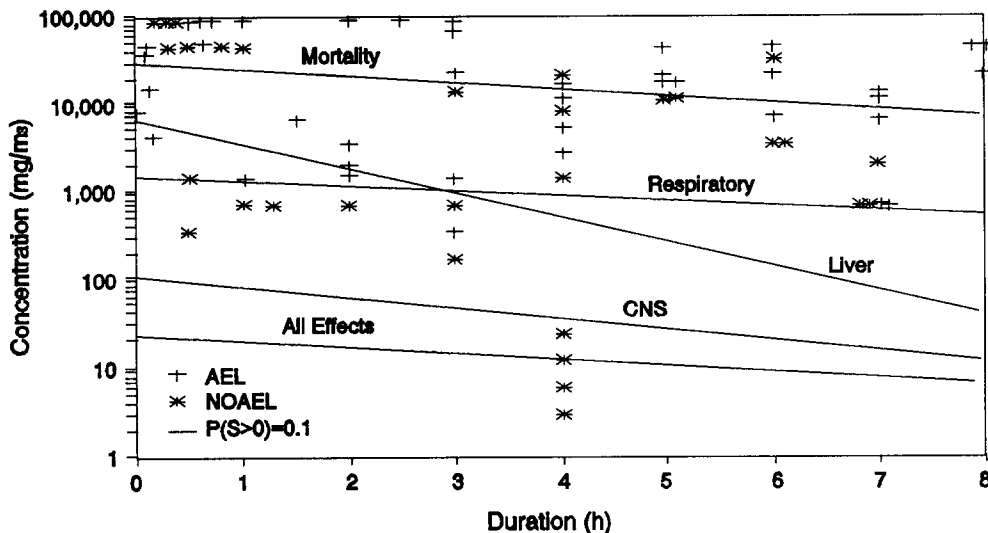

Figure A-13. Categorical regression analysis of tetrachloroethylene: acute effects. Individual regression lines are based on model fit for all observations of specified effects. Each point is an independent exposure group defined as a specific concentration, duration, species, strain, and sex in a study.

Source: Guth et al. (1991).

mechanistic processes are involved for each of those types. As with the other alternative approaches discussed, application of interspecies dosimetry adjustments and UFs for data extrapolation are also warranted.

Development of this model application should also address the appropriateness of combining data of different durations. For the RfC, subchronic and chronic data are of interest to estimate "lifetime" effects. Consideration of temporal aspects of toxicity (see Section 4.3.2) is required. The linearity of responses with exposures is often assumed, but rarely investigated over "lifetime" bioassays.

APPENDIX B

CRITERIA FOR ASSESSING THE QUALITY OF INDIVIDUAL EPIDEMIOLOGICAL STUDIES¹

Human data obviate the need for interspecies extrapolation and thus represent valuable information to dose-response assessment. Scientific controversy sometimes surrounds the interpretation and significance of results when the nature of the study was not experimental. Guidelines for good epidemiology practices, documentation guidance, and guidance on preparation of quality assurance studies for epidemiologic studies have been developed that provide a surrogate to good laboratory practice standards aimed at laboratory animal studies. These guidelines address the process of conducting epidemiologic studies in order to ensure the quality and integrity of the data and to provide adequate documentation of the research methods.

The criteria for assessing the quality of individual epidemiologic studies provided herein are adapted from these guidelines and a number of sources. These criteria are intended to serve as guidance on the evaluation of the quality of the practice with which the study was conducted. These criteria fundamentally represent good scientific practice and thereby impart an index as to the level of uncertainty when utilizing a particular study for dose-response assessment. It is recognized that in some cases, information is not available to ascertain whether all the criteria have been met, in which case judgment is necessary. For example, the typical peer-reviewed journal article lacks some of the information provided in a detailed study report.

1. The relationships, roles, and responsibilities of the organizations and/or individuals sponsoring or conducting the study should be defined in writing. Sponsorship and funding sources should be acknowledged.

¹Adapted from: Interagency Regulatory Liason Group (1981), Lebowitz (1983), American Thoracic Society (1985), Pickrel et al. (1986), and Chemical Manufacturers Association's Epidemiology Task Group (1991).

2. A critical review of the relevant literature to evaluate applicable findings should be provided. The review should encompass laboratory animal and human experiments, clinical studies, vital statistics, and previous epidemiologic investigations. The review should be sufficient to identify potential confounders and effect modifiers.
3. The objectives, specific aims, and rationale of the study should be clearly stated.
4. The overall research design, strategy, and rationale for choosing the proposed study design should be described in relation to the objectives. Limitations of the study design should also be stated. Underlying assumptions and limitations of the design also should be given.
5. Clear definitions of health outcomes, exposure, other measured risk factors, and selection criteria should be provided, as appropriate, for the study population and comparison group (nonexposed and/or referent), morbidity and mortality cases. The study population and comparison group description should include the specific population from which they were drawn and the method of selection. The rationale and criteria for inclusion or exclusion of participants in the study should be given, particularly for exposure classifications. The appropriateness and limitations of the comparison group should be discussed. The extent to which the choice of subjects depended on existing or specially developed record systems, and implications of this upon the analysis, should be considered. The steps taken to ensure confidentiality of the subjects should be accounted for.
6. Data sources for exposure, health status, and risk factors should be described (e.g., questionnaires, biological measurements, exposure/work history record reviews, or exposure/disease registries). The limitations of these sources should be described.
7. Methods of data collection should be described in detail, because these procedures will influence the derived interpretation and inferences. This should include a description of, or reference to, methods used to control, measure, or reduce various forms of error

(e.g., bias due to misclassification, interviewer, or confounding factors) and their impact on the study. The validity (accuracy) and reliability (reproducibility) of the methods used to determine exposure should be stated. Response rates, including reasons for implications of differing rates, should be given. The direction and possible magnitude of any bias introduced into the study as a result of these rates should be described. The procedures used for following the study, methods to ensure completeness, and length of follow-up for each group or subgroup must be included. Other validity checks (e.g., avoiding bias by the independent ascertainment and classification of study variables, such as blind reading of histologic slides or clerical processing of data) also should be included.

8. Major demographic and anthropometric confounding factors should have been accounted for, such as age, sex, ethnic group, socioeconomic status, smoking status, and occupational exposure. The methods employed for these adjustments and their limitations should be discussed. Temperature, season, and day of the week are particularly important for acute studies of respiratory effects and also should be accounted for.
9. The procedures and statistical methods used to describe and analyze the data, estimate parameters, or test specific hypotheses should be presented. References and/or specific formulae also should be given for the statistical tests and for any programming procedures or packages that were applied. The underlying assumptions and potential bias of the statistical methods should be stated. Explicit description of any method used to account for confounding factors (e.g., adjustment or matching) should be described explicitly. This includes methods to account for missing data, such as from nonresponse, attrition, or loss-to-follow-up. When reporting hypothesis tests, the measure of effect, statistical significance, power, and other criteria (e.g., one- versus two-tailed test rationale) should be given. Procedures for obtaining point estimates and their standard errors and/or confidence intervals should be given when using estimation.

10. Criteria for interpreting results should be discussed, including the influence of the limitations of the design, data sources, and analytic methods. Criteria for assessing biologic plausibility, internal and external consistency of the findings, and causal inference (see Appendix C) should be stated.

Often the detailed laboratory reports and documentation of studies are evaluated along with peer-reviewed papers when evaluating data for derivation of an RfC. Quality assurance and guidelines have been developed to ensure that essentially the same requirements provided herein are met and these can be used to assess the quality and data integrity of completed studies (Pickrel et al., 1986; Chemical Manufacturers Association, 1991). Each study should have a written protocol that was approved before the study began. Data are usually considered draft unless the final report has been signed. The following are suggested items for inclusion in a written protocol that should accompany any formal report (Chemical Manufacturers Association's Epidemiology Task Group, 1991).

- A. Descriptive title.
- B. The names, titles, degrees, addresses, and affiliations of the study director, principal investigator, and all co-investigators.
- C. The name(s) and address(es) of the sponsor(s).
- D. An abstract of the protocol.
- E. The proposed study tasks and milestones, including study approval date (date protocol signed by all signatories), study start date (first date the protocol is implemented), periodic progress review dates, and completion date.
- F. A statement of research objectives, specific aims, and rationale (See criteria number 3 above).
- G. A critical review of the relevant literature to evaluate applicable findings (See criteria number 2 above).
- H. A description of the research methods, including:
 1. The overall research design, strategy, and rationale for choosing the proposed study design.
 2. The data sources for exposure, health status, and risk factors.

3. Clear definitions of health outcomes, exposure, and other measured risk factors as well as selection criteria, as appropriate, for exposed and nonexposed persons, morbidity or mortality cases, and referent groups.
 4. Projected study size and, if appropriate, statistical power.
 5. The methods to be used in assembling the study data.
 6. Procedures for handling the data in the analysis.
 7. Methods for data analysis.
 8. Major limitations of the study design, data sources, and analytic methods.
 9. Criteria for interpreting the results.
- I. A description of plans for protecting human subjects.
 - J. A description of, or reference to, quality assurance and quality control procedures for all phases of the study. As appropriate, include certification and/or qualifications of any supporting laboratory or research groups.
 - K. A description of plans for disseminating and communicating study results.
 - L. Resources required to conduct the study.
 - M. The bibliographic references.
 - N. Addenda, as appropriate, including correspondence, collaborative agreements, institutional approval, and samples of the informed consent forms, questionnaires, and representative samples of other documents to be used in the study.
 - O. A dated protocol review and approval sign-off sheet for the study director, principal investigator, co-investigators, and all reviewers.
 - P. Dated amendments to the protocol.

APPENDIX C

CRITERIA FOR CAUSAL SIGNIFICANCE

Statistical methods cannot establish proof of a causal relationship but can define an association with a certain probability. The causal significance of an association is a matter of judgment that goes beyond any statement of statistical probability. To assess the causal significance of an air toxicant and a health effect, a number of criteria must be used, no one of which is pathognomonic by itself. These criteria include the following:

- Consistency (reproducibility) of the association. Causal inferences are strengthened when a variety of investigators have reproduced the findings under a variety of circumstances.
- Strength of the association. The larger the calculated relative risk, the greater the likelihood that the observed association is causal.
- Specificity of the association. Causality is more likely if a particular exposure is associated with only one illness and vice versa. This guideline rarely applies to air pollution research, in which all the diseases of major concern are multifactorial.
- Temporal relationship of the association.
- Coherence of the association. An epidemiologic inference of causality is greatly strengthened when it conforms to knowledge concerning the biologic behavior of a toxicant and its mechanism of action. This evidence may be obtained from clinical research or toxicologic studies.
- Dose-response relationship.

APPENDIX D

ADVERSE HUMAN RESPIRATORY HEALTH EFFECTS

These criteria were developed to assist in the interpretations of the epidemiologic literature on what constitutes an adverse respiratory health effect of air pollution. Adverse human health effects caused by air pollution are listed in hierarchical order, with the most severe at the top and the least severe at the bottom. The reader is referred to the American Thoracic Society (1982, 1985, 1986, 1993) guidelines, Epler et al. (1980), and Chan-Yeung (1987) for more detailed discussion as to what constitutes respiratory impairment in humans and to Appendix E for a discussion of pulmonary function testing data.

1. Increased mortality. ("Increased", as used here and subsequently, means significantly [$p < 0.05$] increased above that recorded in some standard, comparable population. In selected situations, $p < 0.1$ may be appropriate.)
2. Increased incidence of cancer.
3. Increased frequency of symptomatic asthmatic attacks.
4. Increased incidence of lower respiratory tract infections.
5. Increased exacerbations of disease in humans with chronic cardiopulmonary or other disease that could be reflected in a variety of ways, including the following:
 - Less able to cope with daily activities (i.e., shortness of breath or increased anginal episodes);
 - Increased hospitalizations, both frequency and duration;
 - Increased emergency ward or physician visits;
 - Increased pulmonary medication; and
 - Decreased pulmonary function.

6. Reduction in forced expiratory volume at one second (FEV_1) or forced vital capacity (FVC) or other tests of pulmonary function such as the following:
 - Chronic reduction in FEV_1 or FVC associated with clinical symptoms.
 - A significant increase in number of persons with FEV_1 below normal limits; chronically reduced FEV_1 is a predictor of increased risk of mortality. Transient or reversible reductions that are not associated with an asthmatic attack appear to be less important. It should be emphasized that a small but statistically significant reduction in a population mean FEV_1 or $FEV_{0.75}$ is probably medically significant to them, but when diluted with the rest of the population, the change appears to be small.
 - An increased rate of decline in pulmonary function (FEV_1), relative to predicted value in adults with increasing age or failure of children to maintain their predicted FEV_1 growth-curve. Such data must be standardized for sex, race, height, and other demographic and anthropometric factors.
7. Increased prevalence of wheezing in the chest, apart from colds, or of wheezing most days or nights. (The significance of wheezing with colds needs more study and evaluation.)
8. Increased prevalence or incidence of chest tightness.
9. Increased prevalence or incidence of cough/phlegm production requiring medical attention.
10. Increased incidence of acute upper respiratory tract infections that interfere with normal activity.
11. Acute upper respiratory tract infections that do not interfere with normal activity.
12. Eye, nose, and throat irritation that may interfere with normal activity (e.g., driving a car) if severe.
13. Detection of odors.

APPENDIX E

GUIDANCE ON PULMONARY FUNCTION TESTING

The two primary functions of the lung, oxygenation of mixed venous blood and removal of carbon dioxide from that same blood, depend on the integrity of the airways, the vascular system, and the alveolar septa. Inhaled toxic chemicals can affect the integrity of all three of these components. Ideally, tests would be designed to assess the integrity and functional relationships of these structures separately. However, because this is often difficult, many pulmonary function tests evaluate the status of these structural components in an indirect, and often overlapping, way. The myriad of tests include those of pulmonary ventilation, mechanics, distribution, diffusion, and ventilation/blood flows.

During the last three decades, lung function tests have evolved from tools for physiologic study to clinical tools widely used in assessing respiratory status. It has become common to evaluate the results of lung function tests in terms of whether or not they are considered to be within a "normal" range (i.e., represent an "adverse" effect or not). These interpretations are increasingly becoming the basis of dose-response assessments. All clinical measurements, including pulmonary function tests (PFT) are subject to (1) technical variation related to instrument, procedure, observer, subject, and their interactions; (2) biologic variation; and (3) variation caused by dysfunction or disease, the focus of interest for dose-response assessment. Therefore, interpretation of PFT requires establishing the variation of interest (the signal) and its relation to the other sources of variation (the noise).

To maximize the clinical value of lung function testing, the American Thoracic Society (ATS) has outlined the steps necessary to achieve standardization: (1) equipment performance, validation, and quality control; (2) subject performance; (3) measurement procedures to determine acceptability and reproducibility; and (4) reference values and interpretation. These steps form the basis of the criteria outlined here and can loosely be applied to the evaluation of tests on both human and laboratory animals, although in most instances, subject performance is not voluntary in the laboratory animals. Adherence to the

available guidance and recommendations discussed herein should help to ensure that changes in lung function over time and from certain exposures can be correctly interpreted and analyzed without reservation regarding their accuracy and quality.

For more detailed discussion on selection of reference values, interpretative strategies and standardization approaches for pulmonary function testing in humans, the reader is referred to American Thoracic Society (1979; 1987a,b; 1991), Gardner et al. (1986a,b,c), McKay (1986), McKay and Lockey (1991), Folinsbee (1988), Clausen (1982) and Ruppel (1979). This appendix discusses considerations affecting the evaluation of PFT performed on human subjects. For a more detailed discussion as to what constitutes respiratory impairment in humans, the reader is referred to Appendix D and to the American Thoracic Society (1982, 1986, 1993) guidelines, Epler et al. (1980), and Chan-Yeung (1987). Although some of the general concepts are applicable to laboratory animals, some of the procedures and definitions of PFT for laboratory animals are different and these are highlighted at the end of each section. For more detailed discussion of the interpretations and limitations of pulmonary function testing in laboratory animals and their correlates to human PFT, the reader is referred to Costa et al. (1992); Costa and Tepper (1988); Mauderly (1989), and Costa (1985).

E.1 GENERAL DEFINITIONS

This section provides the definitions of (1) the tests commonly used to evaluate pulmonary function and (2) the basic ventilatory defects.

E.1.1 Common Pulmonary Function Tests in Humans

Figure E-1 is a diagrammatic representation of the various lung volumes and capacities based on a typical spirogram and Table E-1 provides the description, determination technique, and significance of each in the context of possible diagnostic use. There are some causes for changes in these tests (e.g., limitation of the movement of the diaphragm by pregnancy, thoracic surgery, or neuromuscular disease) that are not addressed by these comments. It should be recognized that this table is very general and any decision on the significance of

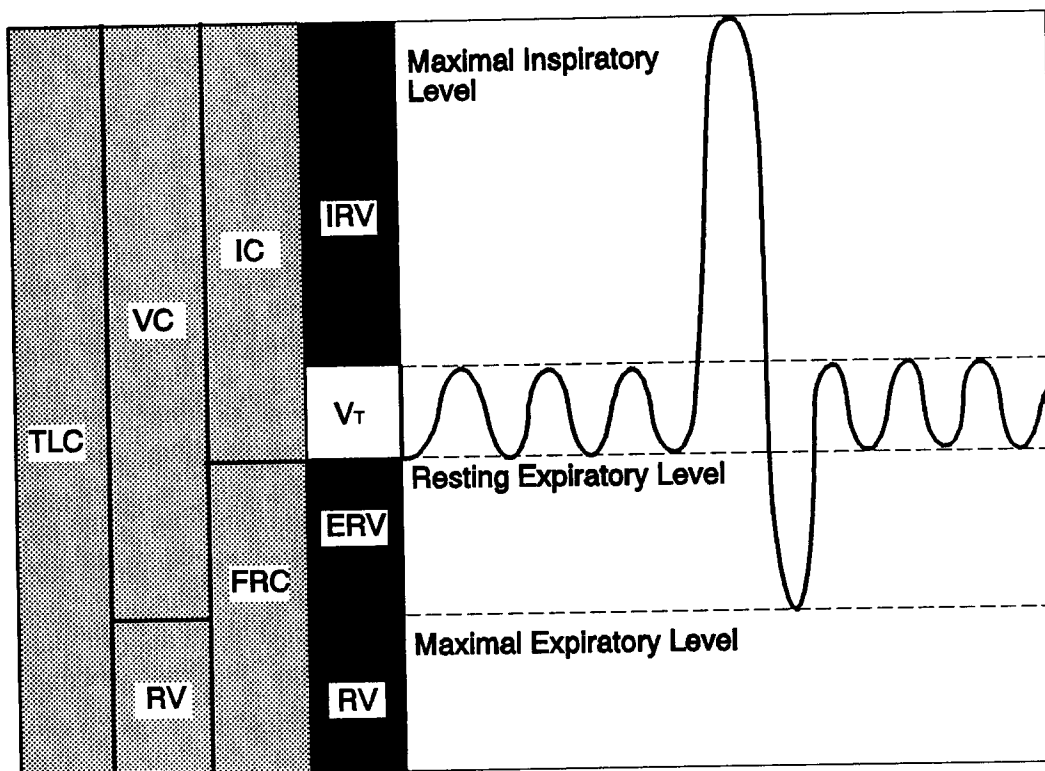

Figure E-1. Lung volumes and capacities. Diagrammatic representation of various lung compartments, based on a typical spirogram. TLC, total lung capacity; VC, vital capacity; RV, residual volume; FRC, functional residual capacity; IC, inspiratory capacity; V_T , tidal volume; IRV, inspiratory reserve volume; ERV, expiratory reserve volume. Shaded areas indicate relationships between the subdivisions and relative sizes as compared to the TLC. The resting expiratory level should be noted, since it remains more stable than other identifiable points during repeated spirometry, hence is used as a starting point for FRC determinations, etc.

Source: Ruppel (1979).

abnormality observed in any given study depends heavily on the circumstances under which the testing was performed.

Pulmonary mechanics tests include the forced vital capacity (FVC), the forced expiratory volume (FEV_T) and the forced expiratory flow at 25 to 75% exhaled FVC ($FEF_{25-75\%}$). All values should be expressed using volumes corrected to body conditions (BTPS): normal body temperature (37 °C), ambient pressure (mm Hg) saturated with water vapor.

TABLE E-1. DEFINITION OF VARIOUS PULMONARY FUNCTION TEST VOLUMES AND CAPACITIES

Volume or Capacity	Description	Technique	Significance
TLC	Total Lung Capacity. The amount of air contained in the lungs at the end of a maximal inspiration.	Usually calculated by combination of other specific lung volumes (e.g., FRC + IC, VC + RV).	TLC is decreased in edema, atelectasis, pulmonary congestion, and restrictive diseases. The TLC may be normal or increased in bronchiolar obstruction with hyperinflation and in emphysema.
VC	Vital Capacity. The largest volume measured on complete expiration after the deepest inspiration without forced or rapid effort.	Vital capacity is measured from maximal inspiration to maximal expiration ("I-E") or maximal expiration to maximal inspiration ("E-I") ¹ .	A decrease in VC may be caused by a loss of distensible lung tissue (e.g., bronchiolar obstruction or pulmonary congestion).
RV	Residual volume. The volume of air remaining in the lungs at the end of a maximal expiration.	RV must be measured indirectly as a subdivision of the FRC, using N ₂ -washout (open-circuit) method or tracer gas dilution (closed circuit).	Increases in RV are characteristic of emphysema and chronic air trapping, as well as chronic bronchial obstruction. RV is typically decreased in restrictive diseases, particularly those associated with extensive fibrosis, such as sarcoidosis, asbestosis, and silicosis. RV may also be decreased in diseases that occlude many alveoli (e.g., pneumonia).
IC	Inspiratory capacity. The largest volume of air that can be inspired from the resting expiratory level.	IC is measured by inhaling maximally from the resting expiratory level or estimated by: VC - ERV.	Changes in the absolute volume of IC usually parallel increases or decreases in the VC. Compensatory hyperventilation normally "dips into" the inspiratory capacity because both the end-inspiratory and end-expiratory levels are altered.
FRC	Functional residual capacity. The volume of air remaining in the lungs at the end-expiratory level.	See RV.	An increased FRC represents hyperinflation that may result from emphysematous changes, asthmatic or fibrotic bronchiolar obstruction. FRC is typically decreased in restrictive diseases, particularly those associated with extensive fibrosis, such as sarcoidosis, asbestosis, and silicosis. FRC may also be decreased in diseases that occlude many alveoli (e.g., pneumonia).

TABLE E-1 (cont'd). DEFINITION OF VARIOUS PULMONARY FUNCTION TEST VOLUMES AND CAPACITIES

Volume or Capacity	Description	Technique	Significance
IRV	Inspiratory reserve volume. The largest volume of air that can be inhaled from the tidal inspiratory volume.	IRV is measured by inhaling maximally from the tidal inspiratory volume.	Changes parallel to those in VC.
V_T	Tidal volume. The volume of air inspired or expired during each respiratory cycle.	V_T is measured directly by simple spirometry. The volume change is measured from the excursions of normal breathing. Because no two breaths are identical, the V_T inhaled or exhaled should be measured for at least 1 minute and then divided by the rate to determine the average.	V_T is not an adequate indicator of alveolar ventilation and should not be considered outside the context of rate and minute volume.
ERV	Expiratory reserve volume. The largest volume of air that can be expired from the end-expiratory level.	ERV is measured by exhaling maximally from the resting expiratory level or estimated by: $VC - IC$.	Changes parallel to those in VC.

¹The closed circuit technique enables evaluation of whether a maximum inspiration was achieved prior to expiration for the "I-E" maneuver (McKay and Lockety, 1991).

The FVC is the volume (liters) of air that can be exhaled as forcefully and rapidly as possible after a maximal inspiration. The test's validity depends heavily on patient effort and cooperation (see footnote to Table E-1). The FEV_T is the volume of air exhaled over a specified time interval (liters per seconds) during the performance of a FVC. The time interval (in seconds) is stated as a subscript to FEV. An interval in common use is the FEV_1 , the volume expired at 1 s. The $FEF_{25-75\%}$ is the mean forced expiratory flow during the middle half of the FVC, formerly called the maximal midexpiratory flow (MMEF). Figure E-2 shows a typical volume-time curve (spirogram) for the FVC maneuver and various FEV_T are indicated.

Bronchial responsiveness is an integrated physiologic mechanism involving airway epithelium, nerves, mediators, and bronchial smooth muscle. Bronchoprovocation challenge testing (BPCT) involves evaluating the changes in FVC, FEV_T , and FEV_1/FVC ratio after exposure to either specific or nonspecific agents capable of producing bronchoconstriction.

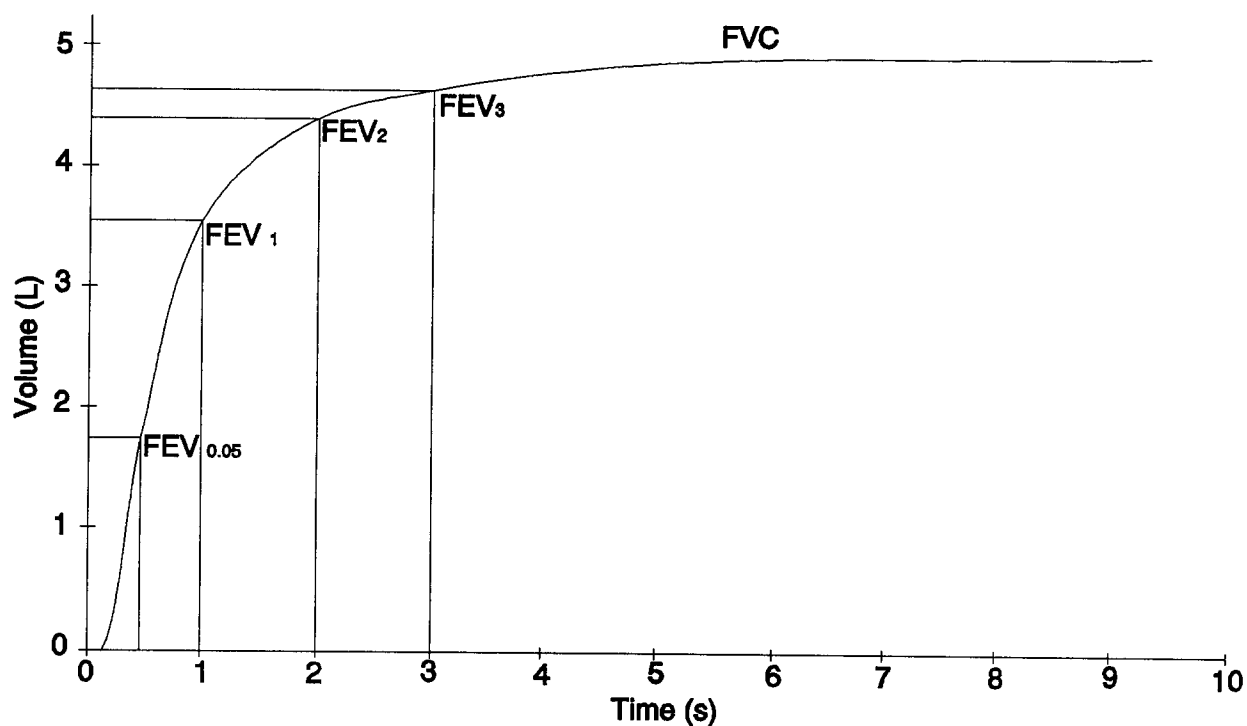

Figure E-2. Volume-time plot (spirogram) of the forced vital capacity (FVC) maneuver. The subject exhaled as forcefully and rapidly as possible from maximal inspiratory level. Forced expiratory volume (FEV) as various time intervals are indicated.

Parasympathomimetic drugs, such as methacholine and carbachol, are used as nonspecific agonists because they cause bronchoconstriction by stimulating acetylcholine receptors located directly on airway smooth muscle. Histamine is another commonly used bronchoconstricting agent. Although its mechanism of action is somewhat controversial, it probably acts indirectly by stimulating cholinergic nerve endings as well as having a direct effect via histamine receptors on airway smooth muscle. Specific agents include common antigens or chemicals such as the isocyanates that may provoke immediate, delayed or dual pulmonary responses that may not resolve spontaneously. Guidelines for standardization have been developed for bronchial inhalation challenges with the nonspecific agonists such as methacholine (Cropp et al., 1980) and adherence to these guidelines should be considered when evaluating such data. Bronchoprovocation challenge testing (BCPT) with specific agents requires more time, expense, and sophisticated equipment and remains more in the realm of research than does nonspecific BCPT, but can also be an extremely useful diagnostic

aid when performed by a quality laboratory. Factors influencing agent-specific BPCT have been discussed elsewhere (McKay, 1986).

Response to bronchodilating agents may also be measured. The within-individual difference in response to different bronchodilators is variable. Because the correlation between bronchoconstriction and bronchodilator response is imperfect, it is not possible to infer with certainty the presence of one from the other. There is no clear consensus on what constitutes reversibility in subjects with airflow obstruction (American Thoracic Society, 1991), however, 20% reversibility is generally believed to be consistent with asthma.

Carbon monoxide diffusing capacity (DL_{CO}) measures all the factors that affect the diffusion of a gas across the alveolo-capillary membrane. Traditional units are mL CO/min/mm Hg at STPD (standard conditions: 0 °C, barometric pressure of 760 mm Hg, 0 mm Hg water pressure). Steady-state or rebreathing techniques are commonly used for human testing. But the single-breath technique (DL_{COsb}) is also commonly used. In general, DL_{CO} is decreased in alveolar fibrosis (e.g., as associated with asbestosis or berylliosis) or interstitial edema. Carbon monoxide diffusing capacity is also decreased in emphysema because of the decrease in alveolar surface area, loss of capillary bed, increased distance from the terminal bronchiole to the alveolocapillary membrane, and the mismatching of ventilation and blood flow. Guidance on standardization has been published elsewhere (American Thoracic Society, 1987b).

The nitrogen washout test measures the concentration of nitrogen in alveolar gas at the end of breathing 100% oxygen for a prescribed period of time (e.g., 7 min). The value is recorded as a percentage of nitrogen. The test is used to determine lung volumes (e.g., the FRC and RV). The FRC and RV are often increased in diseases in which there is an increased airway resistance such as emphysema, chronic bronchitis, and asthma. The RV is raised in these conditions chiefly because airway closure occurs at an abnormally high lung volume. A reduced FRC and RV are often seen in conditions of reduced lung compliance, for example, in diffuse interstitial fibrosis. In this case, the lung is "stiff" and tends to recoil to a smaller RV.

E.1.1.1 Common Pulmonary Function Tests in Laboratory Animals

The conceptual framework for analysis of pulmonary function is quite similar for laboratory animals with the following noteworthy differences:

1. The relevance of the various ATS guidelines is questionable since in many instances they specifically define terms, procedures, and equipment only as they relate to humans. The reviews of Costa (1985), Costa and Tepper (1988), Mauderly (1989), and Costa et al. (1992) put most of the information presented here for the human in the context of small laboratory animals with the various caveats and limitations. The reader is referred to these reviews for more detail than can be provided in these guidelines. For example, if the animal test is done under anesthesia, its body temperature will fall. Unless this measure is monitored and used in the computation of the BTPS adjusted measure (assumed to be 37 °C), the data can differ between studies. Many investigators use actual body temperature (approximately 35 °C) as the BTPS basis so that temperature need not be monitored.
2. The tests described for humans generally require the use of nomogram or other standardized tables based on sex, age, height, and weight of the test subject to compare and determine "normalcy". Laboratory animal studies almost always require the use of comparable control groups (based on the same specio-promorphic considerations) against which determination of effect is established. Anomaly or effect is based on statistical grounds for the group and rarely for the individual (except as part of the overall interpretation).
3. Measures of maximal lung volume in laboratory animals are determined by imposed pressures derived from allometric evaluations of cross-species data, not effort. Since these animal measures are determined under anesthesia, volition is eliminated and the static mechanics of the system can be established. The forced vital capacity measure in the rodent is created differently from that of the human. The interpretation is similar, but reductions in these species respective volumes can differ because of pain in the human maneuver (e.g., after ozone exposure) which the animal will not feel. Nuances can be important. Similarly, the measure of FRC in laboratory animals and humans is different based on the mechanisms establishing this volume. In the human, the volume is based on apposed recoil of the lung and chest wall. In animals with compliant chests this is not the case. Rather, it is set by breathing mechanics and central expiratory control (turned off during anesthesia). Hence, true comparison is difficult. In fact, because the rodent lung has the ability to in part regenerate after acute injury, the FRC response may be the reverse of that of the human (larger than normal instead of smaller). The DL_{CO} can respond in much the same manner.
4. Airway reactivity in the rodent is measured in many different ways. Almost none of these directly parallels the human but the overall interpretations are the same. However, there can be toxicant differential effects in animals when the agonist is delivered to the lung directly versus intravenously. It should be noted

that even within the human study community that the methods used for the testing of airway reactivity differ significantly from laboratory to laboratory. Standardization is more commonplace in true clinical test laboratories than in empirical-clinical study laboratories.

E.1.2 Interpretation of Pulmonary Function Tests and Basic Ventilatory Defects

The vital capacity (VC), FEV₁, and FEV₁/VC ratio are the basic parameters used to interpret spirometry. Although FVC is often used in place of VC, it is preferable to use the largest VC, whether obtained on inspiration (IVC), slow expiration (EVC), or forced expiration (FVC) for clinical testing. Limiting primary interpretation of spirometry to three variables avoids the problem of simultaneously examining a multitude of measurements to see if any abnormalities are present, a procedure that will lead to an inordinate number of "abnormal" tests (American Thoracic Society, 1991). As discussed in other sections of this appendix, the first step in interpreting lung function data should be the evaluation of the quality of the testing. Further, tests interpreted without additional clinical information are limited in their utility to be definitive. Consideration must also be given to (1) the level of reporting and control of technical variation (Section E.2) and (2) the selection of reference values and statistical techniques used to generate predictive values that may be used for interpretation (Section E.4).

E.1.2.1 Definition of an Obstructive Defect

An obstructive ventilatory defect may be defined as a disproportionate reduction of maximal airflow from the lung with respect to the maximal volume (VC) that can be displaced from the lung. It indicates airflow limitation and implies airway narrowing during expiration. The earliest change associated with flow limitation in small airways is thought to be slowing in the terminal portion of the spirogram even when the initial phase is unaffected. This slowing is reflected in a proportionally greater reduction in the instantaneous flow measured after 75% of the FVC has been exhaled (FEF_{75%}) or in the FEF_{25-75%}, than in the FEV₁. Abnormalities in these midrange flow measurements during a forced exhalation are, however, not specific for small airway disease and, though suggestive, should not be used to diagnose small airway disease in individual patients. As airway disease becomes more

advanced and/or more proximal airways become involved, earlier time segments of the forced expiratory maneuver such as the FEV₁ will become reduced out of proportion to the reduction in the VC (American Thoracic Society, 1991).

The FEV₁/VC is recommended as the primary test for distinguishing obstructive from nonobstructive patterns. The FEF_{25-75%} may be used to confirm the presence of airway obstruction in the presence of a borderline FEV₁/VC. The severity of airway obstruction should be based on the FEV₁ rather than the FEV₁/VC (American Thoracic Society, 1991).

E.1.2.2 Definition of a Restrictive Defect

A restrictive ventilatory defect is characterized physiologically by a reduction in TLC. The presence of a restrictive ventilatory defect is inferred when VC is reduced and the FEV₁/FVC is normal or increased. However, severe airflow limitation is another common cause of a reduced VC, either because airflow is so slow the subject can not continue to exhale long enough to complete emptying or because airways collapse. Also, a small VC with a normal FEV₁/VC will occasionally be observed in patients with a normal TLC. Thus, if there is a contradiction between VC and TLC in defining restriction, the classification should be based on the TLC (American Thoracic Society, 1991).

E.1.2.3 Interpretation of Laboratory Animal Tests

A notable difference for interpretation of laboratory animal pulmonary function testing is that these studies typically require cohort control groups because of the many influences on the animal that can not be standardized in textbook nomograms. The reader is referred to the reviews of Costa (1985), Costa and Tepper (1988), Mauderly (1989), and Costa et al. (1992) for important distinctions from human clinical interpretations.

E.2 TECHNICAL SOURCES OF VARIATION (INSTRUMENTATION)

Maximizing the usefulness of spirometry for clinical, diagnostic, or epidemiologic purposes depends on a number of factors that begins with equipment selection. Because spirometry involves effort-dependent maneuvers that require careful patient/subject instruction, understanding, coordination, and cooperation, performance recommendations are

also an important component of ensuring accurate testing. This section discusses specific guidance available on testing equipment, testing performance, quality control, and technician training. This guidance is intended to serve as a framework by which to evaluate the level of certainty in the use of reported spirometry data.

E.2.1 Equipment

Measurement of the deterioration of pulmonary function as an effect of exposure to a toxic chemical may be erroneous if inaccurate spirometers (or other instrumentation) or less sensitive if imprecise spirometers are used. Thus, equipment selection and maintenance is pivotal to ensuring accurate test results. The accuracy of a spirometer systems depends on the resolution (i.e., the minimal detectable volume or flow) and linearity of the entire system—from volume or flow transducer to recorder, display, or processor. Studies should state that the equipment was validated as meeting ATS recommendations. Mention should also be made that equipment quality control procedures were routinely performed, including preventive maintenance, calibration checks, verification and that a quality assurance program was in place to ensure accurate spirometry and test results (American Thoracic Society, 1991; Gardner et al., 1986a,b). Attention must be given to the spirometer temperature where the tests are performed and values reported in BTPS. Quality control should at least include strict adherence to ATS guidelines for equipment performance and calibration (American Thoracic Society, 1991) and additional equipment recommendations have been made by McKay and Lockey (1991).

Measurement procedures have been recommended to ensure that uniform methods are used and that comparable results are obtained (American Thoracic Society, 1991). Medical surveillance and epidemiological studies may require more stringent guidelines to ensure the higher level of quality needed to detect changes from one year to another (McKay and Lockey, 1991). Measurement procedures include how to perform specific maneuvers and thus also define equipment requirements as well. For example, if a test procedure should be carried out for at least a specified amount of time, the spirometer should at a minimum be able to compile data for that duration. Other spirometry system recommendations related to performance procedures include specifications on volume range and accuracy, flow range, resistance and back pressure, time scale (paper speed), volume scale, flow:volume scale,

display axes orientation, and the type of signal used to test the performance for a given maneuver.

E.2.2 Procedure Performance and Measurement

Performance recommendations are an important component of testing because PFT involves effort-dependent maneuvers that require careful patient/subject instruction, understanding, coordination, and cooperation. The largest single source of within-subject variability is improper performance of the maneuvers (American Thoracic Society, 1991). The performance recommendations involve obtaining a sufficient number of maneuvers that are of adequate quality and then determination as to whether these acceptable maneuvers are reproducible. Once maneuvers have been performed, measurement procedures are included to help ensure that uniform methods are used and that comparable results are obtained. Interpretations of spirometry should include a statement about test quality before any other interpretation is rendered.

Guidance on how to perform specific maneuvers (i.e., the VC, FVC, FEV_T, and FEF_{25-75%}) include recommendations on satisfactory start of test criteria, end of test criteria, subject instruction, minimum maneuver time, maximum number of maneuvers, acceptability criteria, use of noseclips, sitting versus standing position, reproducibility criteria, test result selection, and result reporting. If a study does not explicitly state in the methods section that ATS-recommended procedures were performed, the description of the methods for the maneuvers should be compared against the available recommendations (American Thoracic Society, 1991; McKay and Lockey, 1991) to ascertain their credibility.

Proper training of persons administering PFT is the single most important component of a respiratory surveillance program (McKay and Lockey, 1991). Spirometry is not a set of simple procedures to be performed by untrained or minimally trained individuals. The persons administering PFT must do so with skill and understanding. The technician must be able to (1) adequately prepare the subject for testing; (2) identify any preexisting contraindications or reasons to postpone testing; (3) properly instruct, demonstrate, and coach the subject regarding proper technique; and (4) visually inspect each maneuver tracing for validity. The technician must be able to correct and adjust technical problems that may occur and be capable of responding to questions that may arise. The technician must also be

capable of accurately performing hand measurements and calculation and be able to confirm the adequacy of software used for automated calculations. This person should also be able to interpret tests and recognize the effect submaximal effort has on the interpretation process. Studies should state that qualified personnel were used and that a program was in place to evaluate the personnel periodically in order to ensure that accurate and reliable test results were obtained. Testing of commercially available spirometers showed that a major source of errors was in computer software. Due to the increased use of automated systems and computers in pulmonary laboratories, the ATS published "Computer Guidelines for Pulmonary Laboratories" (Gardner et al., 1986c).

E.2.3 Technical Sources of Variation in Laboratory Animal Testing

Throughout this section, application to animal testing requires special considerations.

The most notable are:

1. rapid responding plethysmographic and transducing equipment is required since most of the measures are in the 1-15 mL volume range and the flows perhaps as high as 150 mL/s with a response time of 40 ms or better, and
2. laboratory animals are typically anesthetized and orally or surgically (via the larynx) tracheotomized so that the nose and mouth have no influence.

E.3 BIOLOGICAL SOURCES OF VARIATION

This section outlines sources of variation in PFT related to individual performance on the tests or to host factors, including environmental factors, of the individual tested. The factors are provided here for readers to be aware of as factors that should be controlled for (when possible) in studies that use PFT to index respiratory dysfunction. Some of these factors are explicitly incorporated in algorithms available to calculate normal values for various maneuvers and others are not (see Section E.4). Recommendations to control for some of these (e.g., recommended body position for most maneuvers) have been made to ensure consistency (American Thoracic Society, 1991).

The main sources of intraindividual variation of PFT are (1) body position, (2) head position, (3) effort dependency of maximal flows, and (4) circadian rhythms. The study design should include procedures that ensure consistency relative to these four factors.

The most important host factors that are responsible for interindividual variation in PFT are (1) sex, (2) size, and (3) age, which account for 30, 22, and 8%, respectively, of the variation between adults. Growth affects the relationship between indices of body size and spirometric measurements in children and adolescents. The relationship of ventilatory function to height from childhood through late adolescence to adulthood is not linear. Different prediction equation should be used for the sexes at all ages. Other sources of interindividual variation include (1) race and (2) past and present health.

Exposure to tobacco smoke is by far the most important factor known to alter lung function. A clear choice for the most appropriate method of adjusting spirometric indices for the effect of smoking is not readily evident from published data in which any of the following have been used: smoking status (current smoker or exsmoker), amount currently smoked, duration of smoking, and pack-years. Neglecting the correlation of some of these factors, (e.g., pack-years) with age can introduce errors in analyzing the effects of smoking. Smoking should be handled as an independent variable as its distribution in the reference population and its relation to other health indicators will affect any predictive regression terms calculated. Other environmental factors that contribute to interindividual variation include (1) geographic factors, (2) exposure to environmental and occupational pollution, and (3) socioeconomic status.

The reader is referred to the reviews of Costa (1985), Costa and Tepper (1988), Mauderly (1989), and Costa et al. (1992) for specific considerations in laboratory animals.

E.4 REFERENCE VALUES: SOURCES, SELECTION AND STATISTICAL ISSUES¹

Predicting the presence or absence of disease requires knowledge about the distribution of dysfunction in various disease states and the prior probability of disease. Subjects with similar characteristics for the major variables that affect lung function (sex, age, height, and race) can be grouped together in a stratum or a cell. Comparing the performance of an individual subject with the values generated from a reference population requires knowledge about the data in the appropriate cell (i.e., the number in the cell, measures of central

¹Text adapted from American Thoracic Society (1991). Reader is referred to these guidelines for additional detail.

tendency such as the mean value, estimates of dispersion such as variance or standard deviation [SD], and information about the symmetry of the distribution). If the number of subjects in each cell is sufficient, PFT can be described by providing descriptors of the distribution such as mean and SD. Such tabulations are infrequently used for PFT because there are too many possible cells to consider all possible combinations of age and height.

Regression equations are an economical and efficient alternative method to describe expected values as a function of sex, height, and age. Regression techniques assume that PFT varies in a symmetric fashion about the mean value in each cell and that the variance about the mean is constant from one cell to another. The closer the distribution of PFT values come to symmetry or, better still, to a Gaussian distribution within cells, the more it is possible to take advantage of the equations. Distributions of FEV₁ and FVC in population studies are usually found to be close to Gaussian in the middle age range, not at the extremes. Ideally, publications describing reference populations should include, not only the prediction equations, but also a means of defining their lower limits. In the absence of explicit recommendations, a lower limit can be estimated from a regression model. For spirometry, values below the fifth percentile are taken as below the expected range (below the "lower limit of normal") and those above the fifth percentile are taken as within the expected range. This implies a 5% false positive misclassification, a rate generally considered acceptable.

The most commonly reported measures of how well regression equations fit the data are the square of the correlation coefficient (r^2) and the standard error of the estimate (SEE). The proportion of variation in the observed data explained by the independent variables is measured by r^2 . The SEE is the average SD of the data around the regression line. Because these two statistics reflect average characteristics of the regression, r^2 and SEE may not reflect the ability of the equation to describe the tails of the distribution or the limits of "normal", and therefore are not sufficient criteria on which to choose the best equations to evaluate a population.

Linear regression is the most common but not the only model used to describe PFT data in adults. Such equations perform less well at the edges of the data distribution and in those cells where there are few data. Estimates are likely to be misleading if they go beyond the range of the independent variables used to create the equation.

Criteria for selecting reference values to be used fall into three categories:

(1) methodologic, (2) epidemiologic, and (3) statistical. Reference values should be based on data obtained with the same instruments and methods comparable to those used for the population for which the reference values are being selected. The population from which the subjects are drawn should be similar with respect to age, height, sex, and ethnic composition to the population to whom the prediction values are to be applied. Prediction equations should use age, height, sex, and ethnic group as independent variables. For most uses, they should be based on cross-sectional studies of lifetime nonsmokers. Both biologic plausibility and simplicity in the model used to develop prediction equations are important issues in the selection of reference values. Other statistical aspects have been described above. Selected published reference equations for adult whites and blacks and scaling factors for blacks currently in use have been published. Studies should use the published reference equations that most closely describe the population being tested.

The practice in many clinical laboratories has been to classify values of FVC and FEV_1 less than 80% of predicted as abnormal. This fixed value has no statistical basis in adults.

Cross-sectional data are subject to a bias called "cohort" effect. A person who is 40 years of age today is different from one who became 40 two decades ago because of a variety of host and environmental factors. The age-related lung function deficit predicted from cross-sectional data tends to be greater than that predicted from longitudinal PFT data in adults and children. Prediction equations based on cross-sectional data are appropriate for determining the prevalence of PFT impairment in defined populations. They are less well-suited to determine age-related events including the incidence or progression of impairment. Reliance can be placed on the FEV_1 and VC for examining changes over time as they are the only spirometric variables that will consistently and correctly reflect the direction of the change in overall PFT. Difficulty remains, however, in determining whether a change is "real" or only a result of test variability. All PFT measurements tend to be more variable when made weeks to months apart than when repeated at the same session or even daily. It is more likely that a real change has occurred when there are a series of tests that show a consistent trend. As shown in Table E-2, significant changes, whether statistical or biologic, vary by parameter, time period, and the type of patient.

TABLE E-2. CHANGE IN SPIROMETRIC INDICES OVER TIME

	Percent Changes Required To Be Significant		
	FVC	FEV ₁	FEF _{25-75%}
Within a day			
Normal subjects	≥5	≥5	≥13
Patients with COPD	≥11	≥13	≥23
Week to week			
Normal subjects	≥11	≥12	≥21
Patients with COPD	≥20	≥20	≥30
Year to year	≥15	≥15	

E.4.1. Reference Values for Laboratory Animal Testing

The discussion above generally applies to laboratory animal studies with the exception noted above that the study design should include empirical control cohorts. Considerations for establishing such controlled studies are presented in the reviews of Costa (1985), Costa and Tepper (1988), Mauderly (1989), and Costa and Tepper (1992).

E.5 INTERPRETIVE STRATEGIES: CONCEPTUAL ISSUES CONCERNING NORMALITY AND THE LIMITS OF NORMAL FOR DESIGNATING ADVERSE-EFFECT LEVELS

To draw inferences about the presence of disease from one test, the prior probability that the patient has the disease and the distributions of test values for subjects with and without the disease in question should ideally be known. Although this ideal is rarely met, understanding of the testing situation should be used to put an interpretation of PFT in proper perspective. The "normal" range only gives information about the distribution of test results in the healthy population from which they were derived. It says nothing about the true positive rate, the false negative rate, or the predictive power of a positive test.

As discussed in the preceding sections, consideration must be made of the appropriateness of the equipment, performance maneuvers, biologic variation and selection, including statistical procedures, used to derive normal reference values. In summary, studies

should indicate in the methods section the source of reference values used for their reports. Prediction equations for adults should include age, sex, and height as independent variables. It is preferable to choose reference values for both sexes from the same population source. Smoking status as an independent variable has been discussed in Section E.3. Altitude can be important in the selection of reference values for flow rates and for DL_{CO} . The equations should come from studies that present lower limits of normal or present information from which such lower limits can be calculated. In general, the prediction equations should not be extrapolated for ages or heights beyond those covered by the data on which they are based. The use of 80% of predicted for a lower limit of normal for adult PFT maneuvers is not recommended. Because of unexplained differences between published reference values, no one set of reference values is likely to be applicable to all studies performed. It is preferable that studies performed on populations in North America use reference values based on North American populations. European studies should use reference values based on European populations.

If there are any reasons to suspect the quality of the test performance, specific designation of adverse effect levels should be avoided. Dysfunction discovered under these conditions should indicate only the need for more definitive testing. General definitions of respiratory dysfunction are provided in Section E.1.2.2, but determination of the severity or degree of dysfunction must be made in the context of the other considerations discussed above, particularly the appropriateness of the reference values and statistical procedures used to describe "normal". Finally, borderline "normal" values should be interpreted with caution. Such interpretations should, when possible, use additional clinical information in the decisions in order to designate an adverse-effect level or a no-adverse-effect level.

E.5.1 Interpretive Strategies for Animal Testing

Again, the concepts outlined above generally apply to animal testing with a few notable differences. Although spirometric measures in animals appear to be consistent over time, no real investigation of this has been conducted. It should be pointed out, however, that most rodents grow throughout life and their age dependent spirometry appears to improve (by anthropomorphic standards) over the same period until just before death. This is quite unlike the human which begins to have less than optimal performance beyond young adulthood

(around 21 years of age). The DL_{CO} in rodents also improves over most of life but begins to diminish before the fall in spirometry. This is not the case in humans.

APPENDIX F

CRITERIA FOR ASSESSING THE QUALITY OF INDIVIDUAL LABORATORY ANIMAL TOXICITY STUDIES¹

A minimally acceptable study should meet the following criteria, which fundamentally represent good scientific practice.

1. All elements of exposure should be clearly defined.
 - The exposure concentration, administration route, exposure schedule, and exposure duration must be described. Consideration should also be given to the concentration and time of exposure used versus the expected level of human exposure.
 - If animal body weights, ages, or sex are not provided, consideration should be given to the uncertainty in appropriate default values.
 - Exposure information should include physicochemical characteristics of the substance used, such as purity, stability, pH, partition coefficient, particle size and distribution, breathing zone concentration, and vehicle. These properties can influence the local effects and the rate and extent of absorption, which can subsequently modify the toxic manifestations. Concentrations should be reported as means and variances.
 - Exposure information should include a description of generation and characterization technology used (e.g., chamber design, type, dimensions, uniformity of distribution, source of air, generating system, air conditioning, and exhaust treatment). The number of air changes, air flow rate, oxygen content, temperature, and relative humidity are exposure chamber characteristics that should be monitored and reported as means and variances. The description of the characterization method(s) should also include frequency of measurement, calibration of the measurement instrument, frequency of the calibration, and other quality assurance elements. Cage (or other animal holder) rotation schedule should be described.

¹Adapted from Society of Toxicology (1982), Muller et al. (1984), National Research Council (1984), James (1985), and Lu (1985a).

- Animal care and holding procedures should be described.
2. Controls should be comparable with test animals in all respects except the treatment variable ("negative").
 - Concurrent controls must minimally include an "air-only" exposure group; if a vehicle is used, it is desirable that there be a "vehicle-only" group.
 - Historical control data can be useful in the evaluation of results, particularly where the differences between control and treated animals are small and are within anticipated incidences based on examination of historical control data.
 3. Endpoints should address the specific hypothesis being tested in the study, and the observed effects should be sufficient in number or degree (severity) to establish a dose-response relationship that can be used in estimating the hazard to the target species.
 - The outcome of the reported experiment should be dependent on the test conditions and not influenced by competing toxicities.
 4. The test performed must be valid and relevant to human extrapolation. The validity of using the test to mimic human responses must always be assessed. Issues to consider include the following:
 - Does the test measure an established endpoint of toxicity or does it measure a marker purported to indicate an eventual change (i.e., severity of the lesion)?
 - Does the test indicate causality or merely suggest a chance correlation?
 - Was an unproven or unvalidated procedure used?
 - Is the test considered more or less reliable than other tests for that endpoint?
 - Is the species a relevant or reliable human surrogate? If this test conflicts with data in other species, can a reason for the discrepancy be discerned?
 - How reliable is high exposure (animal) data for extrapolation to low exposure (human scenario)?

5. Conclusions from the experiment should be justified by the data included in the report and consistent with the current scientific understanding of the test, the endpoint of toxicology being tested, and the suspected mechanism of toxic action.
6. Due consideration in both the design and the interpretation of studies must be given for appropriate statistical analysis of the data.
 - Statistical tests for significance should be performed only on those experimental units that have been randomized (some exceptions include weight-matching) among the dosed and concurrent control groups.
 - Some frequent violations of statistical assumptions in toxicity testing include:
 - Lack of independence of observations.
 - Assuming a higher level of measurement than available (e.g., interval rather than ordinal).
 - Inappropriate type of distribution assumed.
 - Faulty specification of model (i.e., linear rather than nonlinear).
 - Heterogeneity of variance or covariance.
 - Large Type II error.
7. Subjective elements in scoring should be minimized. Quantitative grading of an effect should be used whenever possible.
8. Peer review of scientific papers and of reports is extremely desirable and increases confidence in the adequacy of the work.
9. When the data are not published in the peer-reviewed literature, evidence of adherence to good laboratory practices is highly recommended, with rare exceptions.
10. Reported results have increased credibility if they are reproduced (confirmed) by other researchers and supported by findings in other investigations.

11. Similarity of results to those of tests conducted on structurally related compounds should be considered.

The reader is also referred to Part 798, the Health Effects Testing Guidelines, of the U.S. Toxic Substances Control Act Test Guidelines delineated in 40 Code of Federal Regulations (1991d). The chronic testing guidelines for all administration routes are provided in Subpart D, Section 798.3260. Subpart C, Section 798.2450, and Subpart B, Section 798.1150, describe the guidelines for subchronic and acute inhalation testing, respectively. Guidelines for inhalation developmental toxicity testing are discussed in Subpart E, Section 798.4350.

These guidelines provide recommendations on laboratory animal selection (e.g., species, number, sex, age, and condition); on number of test concentrations and the objectives of each; on physical parameters of exposure that should be monitored and recorded and with what frequency (e.g., chamber air changes, oxygen content, air flow rate, humidity, and temperature); on what testing conditions should be reported and how (e.g., mean and variance of both nominal and breathing zone exposure concentration, particle size, and geometric standard deviation); and on what gross pathology and histopathology, clinical, biochemical, hematological, ophthalmological, and urinary excretion tests to perform, intervals at which to perform them, which exposure levels to process these data for, and how to report their results.

The recommendations on what diagnostic tests to perform and how to report the data are particularly useful for evaluating a given study. Although the mechanism of action should dictate the repertoire of tests performed, Table F-1 provides a general list of recommended clinical biochemistry examinations; and Table F-2 provides a list of organs and tissues recommended for histological examination. If specific mechanisms of action are hypothesized, specific assays or functional tests for those would be added. It is also important to establish that appropriate removal and tissue processing was performed.

Results should be reported in tabular form, showing the number of animals at test start, number with lesions, the types of lesions, and the percentage of animals with each type. Group animal data should be reported to show number of animals dying, number showing signs of toxicity, and number exposed. Individual animal data should include time of death;

TABLE F-1. GENERAL CLINICAL BIOCHEMISTRY EXAMINATIONS

Calcium
Phosphorus
Chloride
Sodium
Potassium
Fasting glucose
Serum glutamic-pyruvic transaminase (serum alanine aminotransferase)
Serum glutamic-oxaloacetic transaminase (serum aspartate aminotransferase)
Ornithine decarboxylase
Gamma glutamyl transpeptidase
Urea nitrogen
Albumin
Blood creatinine
Creatinine phosphokinase ^a
Total cholesterol ^a
Total bilirubin
Total serum protein
Lipids ^b
Hormones ^b
Acid/base balance ^b
Methemoglobin ^b
Cholinesterase activity ^b

^aSuggested for chronic inhalation toxicity test.

^bMay be required for a complete toxicological evaluation.

Source: Shoaf (1993).

time of observed toxicity; body weight; food consumption; and results of hematological tests, clinical biochemistry tests, necropsy, histopathology, and statistical analyses.

TABLE F-2. ORGANS AND TISSUES PRESERVED FOR HISTOLOGICAL EXAMINATION

All gross lesions	Aorta
Nasopharyngeal tissues	Gall bladder
Lungs ^a	Esophagus
Trachea	Stomach
Pituitary	Duodenum
Thyroid/parathyroid	Jejunum
Thymus	Ileum
Brain and sections ^b	Cecum
Heart	Colon
Sternum with bone marrow	Rectum
Salivary glands	Urinary bladder
Liver	Representative lymph node
Spleen	Peripheral nerve
Kidney	Thigh muscle ^c
Adrenals	Mammary gland ^c
Pancreas	Eyes ^c
Gonads	Skin ^c
Uterus	Spinal cord ^{c,d}
Accessory genital organs ^{c,e}	Exorbital lachrymal glands ^c

^aRemoved intact, weighed, and treated with fixative (e.g., perfusion) to ensure maintenance of lung structure.

^bMedulla/pons, cerebellar cortex, and cerebral cortex.

^cIf indicated by signs of toxicity or as a target organ.

^dCervical, midthoracic, and lumbar.

^eEpididymis, prostate, seminal vesicles.

Source: Shoaf (1993).

APPENDIX G

THE PARTICLE DEPOSITION DOSIMETRY MODEL

In this appendix, the revised empirical model used to estimate fractional regional deposition efficiency for calculation of RDDR (Equation 4-5) to be used as a dosimetric adjustment factor is described (Ménache et al., submitted). This revised model represents refinement of previously published models used to calculate the RDDR in the 1990 interim RfC methods (Jarabek et al., 1989, 1990; Miller et al., 1988). For example, rather than linear interpolation between the published (Raabe et al., 1988) means for deposition measured at discrete particle diameters, as previously done for the laboratory animal deposition modeling, equations have now been fit to the raw data as described herein.

The equations to perform calculations for monodisperse particles are provided; how the calculated efficiencies may be transformed to fractional depositions is indicated; how to use the model to predict deposition fractions for polydisperse particles is explained; and the effects of the mass median aerodynamic diameter (MMAD) and the geometric standard deviation (σ_g) on the regional deposited dose ratio (RDDR_r) calculations are illustrated. Because \dot{V}_E must be calculated from the default body weights (Table 4-5) using allometric scaling (Equation 4-4) for use as input to the empirical model, the example of hand calculation of monodisperse deposition includes a \dot{V}_E calculation.

Fractional deposition of particles in the airways of the respiratory tract may be estimated using theoretical or empirical models or some combination of the two. Progress is being made in answering the data needs of theoretical models (e.g., exact airflow patterns, complete measurements of the branching structure of the respiratory tract, pulmonary region mechanics), however, many uncertainties remain. Empirical models are systems of equations that are fit to experimentally determined deposition in vivo. These models do not require the detailed information needed for theoretical models, however, they can not provide estimates of dose to localized specific sites (e.g., respiratory versus olfactory nasal epithelium terminal bronchioles, carinal ridges). Measurement techniques are such that only general regions can

be defined (Stahlhofen et al., 1980; Lippmann and Albert, 1969; Raabe et al., 1977) which limits the regions that can be defined for a dosimetry model. Despite this level of generality, regional information is available now for humans and a number of commonly used laboratory animals. Empirical models of regional fractional deposition have been presented for humans (Yu et al., 1981; Miller et al., 1988; Stahlhofen et al., 1989). The empirical model described in this appendix was fit for five species of commonly used laboratory rodents using experimental data received from Dr. Otto Raabe (Raabe et al., 1988). At the same time, Dr. Morton Lippmann (Lippmann and Albert, 1969; Lippmann, 1970, 1977; Chan and Lippmann, 1980; Miller et al., 1988) and Dr. Wilhelm Stahlhofen and colleagues (Stahlhofen et al., 1980, 1983, 1989; Heyder and Rudolf, 1977; Heyder et al., 1986) provided the individual experimental measurements from their published studies. Using these data, the human model published in Miller et al. (1988) was extended by refitting the extrathoracic (ET) (oral breathing) and tracheobronchial (TB) deposition efficiencies with the original raw data as well as by fitting a pulmonary (PU) deposition efficiency equation (Ménache et al., submitted).

G.1 EMPIRICAL MODEL FOR REGIONAL FRACTIONAL DEPOSITION EFFICIENCIES

The equations describing fractional deposition were fit using data on particle deposition in CF₁ mice, Syrian golden hamsters, Fischer 344 rats, Hartley guinea pigs, and New Zealand rabbits. A description of the complete study including details of the exposure may be found elsewhere (Raabe et al., 1988). Briefly, the animals were exposed to radiolabelled ytterbium (¹⁶⁹Yb) fused aluminosilicate spheres in a nose-only exposure apparatus. Twenty unanesthetized rodents or eight rabbits were exposed simultaneously to particles of aerodynamic diameters (d_{ae}) about 1, 3, 5, or 10 μm . Half the animals were sacrificed immediately post exposure; the remaining half were held 20 h post exposure. One-half of the animals at each time point were male and the other half were female. The animals were dissected into 15 tissue compartments, and radioactivity was counted in each compartment. The compartments included the head, larynx, GI tract, trachea, and the five lung lobes. This information was used directly in the calculation of the deposition fractions. Radioactivity was

also measured in other tissues including heart, liver, kidneys, and carcass; and additionally in the urine and feces of a group of animals held 20 hours. In the animals sacrificed immediately post exposure, these data were used to ensure that there was no contamination of other tissue while the data from the animals held 20 hours were used in the calculation of a fraction used to partition thoracic deposition between the TB and PU regions. This partition is discussed below briefly and described in detail elsewhere (Raabe et al., 1977). Finally, radioactivity was measured in the pelt, paws, tail, and headskin as a control on the exposure.

Although there are some other studies of particle deposition in laboratory animals (see review by Schlesinger, 1985), no other data have the level of detail or the experimental design (i.e., freely breathing, unanesthetized, nose-only exposure) required to provide deposition equations representative of the animal exposures used in many inhalation toxicology studies. However, many inhalation toxicology studies are not nose-only exposures. While this is a necessary exposure condition to determine fractional particle deposition, adjustments for particle inhalability and ingestion can be made to estimate deposition fractions under whole-body exposure conditions.

The advantages of using the data of Raabe et al. (1988) to develop the deposition equations include:

- the detailed measurements were made in all tissues in the animal, providing mass balance information and indicating that there was no contamination of nonrespiratory tract tissue with radioactivity immediately post exposure,
- the use of five species of laboratory animals under the same exposure conditions,
- the use of unanesthetized, freely breathing animals, and
- the use of an exposure protocol that makes it virtually impossible for the animals to ingest any particles as a result of preening.

Regional fractional deposition, F_r , was calculated as activity counted in a region normalized by total inhaled activity (Table G-1). The proportionality factor, f_L , in Equations G-2 and G-3 is used to partition thoracic deposition between the TB and PU regions. It was calculated using the 0 and 20-h data and is described in detail by Raabe and co-workers (1977).

TABLE G-1. REGIONAL FRACTIONAL DEPOSITION

$F_r = \frac{\text{Activity Counted in a Region}}{\text{Total Inhaled Activity}}$	
Extrathoracic (ET): $F_{ET} = \frac{[\text{head} + \text{GI tract} + \text{larynx}]_{0\text{ h}}}{\text{Total Inhaled Activity}}$	(G-1)
Tracheobronchial (TB): $F_{TB} = \frac{\text{trachea}_{0\text{ h}} + f_L \times \sum_{i=1}^5 \text{lobe}_{i,0\text{ h}}}{\text{Total Inhaled Activity}}$	(G-2)
Pulmonary (PU): $F_{PU} = \frac{(1 - f_L) \times \sum_{i=1}^5 \text{lobe}_{i,0\text{ h}}}{\text{Total Inhaled Activity}}$	(G-3)

These regional deposition fractions, F_r , however, are affected not only by the minute volume (\dot{V}_E), MMAD and σ_g , but also by deposition in regions through which the particles have already passed. Deposition efficiency, η_r , on the other hand, is affected only by \dot{V}_E , MMAD, and σ_g . The differences between deposition fraction and efficiency, calculated as described below, are described in more detail later in this appendix. In the aerodynamic domain, that is for particles with diameters $>0.5 \mu\text{m}$ (see Appendix H for further discussion of particle dimension issues), efficiencies increase monotonically and are bounded below by 0 and above by 1. The logistic function (Equation G-4) has mathematical properties that are consistent with the shape of the efficiency function (Miller et al., 1988):

$$E(\eta_r) = \frac{1}{1 + e^{\alpha + \beta \log_{10} x}}, \quad (\text{G-4})$$

where $E(\eta_r)$ is the expected value of deposition efficiency (η_r) for region r , and x is expressed as an impaction parameter, $d_{ae}^2 Q$, for extrathoracic deposition efficiency and as aerodynamic particle size, d_{ae} , for TB and PU deposition efficiencies. The flow rate, Q , in the impaction parameter may be approximated by $\dot{V}_E/30$. The parameters α and β are estimated using nonlinear regression techniques.

To fit this model, efficiencies must be derived from the deposition fractions that were calculated as described in Table G-1. Efficiency may be defined as activity counted in a region divided by activity entering that region. Then, considering the region as a sequence of filters in steady state, efficiencies may be calculated as follows:

$$\eta_{ET} = F_{ET} \quad (G-5)$$

$$\eta_{TB} = \frac{\text{trachea}_{0h} + f_L \times \sum_{i=1}^5 \text{lobe}_{i,0h}}{(1 - \eta_{ET})} \quad (G-6)$$

$$\eta_{PU} = \frac{(1 - f_L) \times \sum_{i=1}^5 \text{lobe}_{i,0h}}{(1 - \eta_{ET})(1 - \eta_{TB})} \quad (G-7)$$

Using these calculated regional efficiencies in the individual animals, the logistic function (Equation G-4) was fit for the ET, TB, and PU regions for the five animal species and humans. The parameter estimates from these fits are listed in Table G-2. Curves produced by these equations have been compared where applicable to the data reported in Schlesinger (1985), and the results are not inconsistent. As discussed by Schlesinger (1985), there are many sources of variability that could explain differences in predicted deposition using this model and the observed deposition data in the studies reported by Schlesinger (1985).

G.2 TRANSFORMING FITTED EFFICIENCIES TO PREDICTED REGIONAL FRACTIONAL DEPOSITION

The fitted equations are then used to generate predicted efficiencies (η) as a function of impaction in the ET region and of aerodynamic particle size in the TB and PU regions. Finally, the predicted efficiencies are multiplied together and adjusted for inhalability, I , as shown in Equations G-8 through G-10 to produce predicted deposition fractions (F_p) for monodisperse and near monodisperse ($\sigma_g < 1.3$) particles.

**TABLE G-2. DEPOSITION EFFICIENCY EQUATION
ESTIMATED PARAMETERS**

Species	ET (Nasal)		TB		PU	
	α	β	α	β	α	β
Human	7.129 ^a	-1.957 ^a	3.298	-4.588	0.523	-1.389
Rat	6.559	-5.524	1.873	-2.085	2.240	-9.464
Mouse	0.666	-2.171	1.632	-2.928	1.122	-3.196
Hamster	1.969	-3.503	1.870	-2.864	1.147	-7.223
Guinea Pig	2.253	-1.282	2.522	-0.865	0.754	0.556
Rabbit	4.305	-1.628	2.819	-2.281	2.575	-1.988

^aSource: Miller et al., 1988.

$$\hat{F}_{ET} = I \times \hat{\eta}_{ET} \quad (G-8)$$

$$\hat{F}_{TB} = I \times (1 - \hat{\eta}_{ET}) \times \hat{\eta}_{TB} \quad (G-9)$$

$$\hat{F}_{PU} = I \times (1 - \hat{\eta}_{ET}) \times (1 - \hat{\eta}_{TB}) \times \hat{\eta}_{PU} \quad (G-10)$$

Inhalability, I , is an adjustment for the particles in an ambient exposure concentration that are not inhaled at all. For humans, an equation has been fit using the logistic function (Ménache et al., 1995). Using the experimental data of Breysse and Swift (1990):

$$I = 1 - \frac{1}{1 + e^{10.32 - 7.17 \log_{10} d_{ae}}} \quad (G-11)$$

The logistic function was also fit to the data of Raabe et al. (1988) for laboratory animals (Ménache et al., 1995):

$$I = 1 - \frac{1}{1 + e^{2.57 - 2.81 \log_{10} d_{ae}}} \quad (G-12)$$

For example, calculation of \hat{F}_{PU} for a female Syrian golden hamster exposed to a nearly monodisperse particle ($\sigma_g < 1.3$) with an MMAD of 1.8 in a subchronic study would proceed as follows.

1. Calculate the default \dot{V}_E . (If the study for which the $RDDR_{PU}$ is being calculated has information on experimentally measured \dot{V}_E , that information may be substituted for the default value; however, this could necessitate changes to surface areas and body weight (if extrapulmonary tract effects are being examined). If there is inadequate information to change *all* of these values, then the default values should be used.)
 - a. The default body weight for a female Syrian hamster in a subchronic study from Table 4-4 is 0.095 kg.
 - b. Calculation of \dot{V}_E expressed in natural logarithms using hamster coefficients from Table 4-5:

$$\begin{aligned}\log(\dot{V}_E) &= -1.054 + 0.902 \times \log(0.095) \\ &= -3.177\end{aligned}$$
 - c. Convert from natural logs to arithmetic units

$$\exp(-3.177) = 0.0417$$
 - d. Convert from L to mL by multiplying by 1,000

$$\dot{V}_E = 41.7$$
2. Calculate the impaction parameter as $MMAD^2 \times \dot{V}_E/30$ for the ET region

$$\begin{aligned}&= (1.8)^2 \times (41.7/30) \\ &= 4.504 \\ &\text{and take the } \log_{10} \\ &= 0.654\end{aligned}$$
3. Calculate $\hat{\eta}_{ET}$ using the parameters from Table G-2

$$\begin{aligned}&= 1/(1 + \exp(1.969 - 3.503 \times 0.654)) \\ &= 0.580\end{aligned}$$

4. Calculate \log_{10} (MMAD) for the TB and PU regions

$$\begin{aligned} &= \log_{10}(1.8) \\ &= 0.255 \end{aligned}$$

5. Calculate $\hat{\eta}_{TB}$ using the parameters from Table G-2

$$\begin{aligned} &= 1/(1 + \exp(1.870 - 2.864 \times 0.255)) \\ &= 0.242 \end{aligned}$$

6. Calculate $\hat{\eta}_{PU}$

$$\begin{aligned} &= 1/(1 + \exp(1.147 - 7.223 \times 0.255)) \\ &= 0.667 \end{aligned}$$

7. Calculate the inhalability fraction, I

$$\begin{aligned} &= 1 - (1/(1 + \exp(2.57 - 2.81 \times 0.255))) \\ &= 0.865 \end{aligned}$$

8. Calculate \hat{F}_{ET} (if desired)

$$\begin{aligned} &= 0.865 \times 0.580 \\ &= 0.502 \end{aligned}$$

9. Calculate \hat{F}_{TB} (if desired)

$$\begin{aligned} &= 0.865 \times (1 - 0.580) \times 0.242 \\ &= 0.088 \end{aligned}$$

10. Calculate \hat{F}_{PU}

$$\begin{aligned} &= 0.865 \times (1 - 0.580) \times (1 - 0.242) \times 0.667 \\ &= 0.184 \end{aligned}$$

These hand-calculated fractional depositions for monodisperse particles might differ slightly from the fractions generated by the computer program due to rounding errors. In particular, the parameter estimates in Table G-2 are only reported to three decimal places but are used with nine decimal places in the program. Because all of these digits are not significant, however, **the deposition fractions should never be reported to more than two digits.**

The human deposition fractions may be calculated using the same strategy. The only default \dot{V}_E , however, is 13.8 L/min. As described in step 1.d, this value should be

converted to mL by multiplying by 1,000. The information provided in Table G-2 allows for estimation of deposition in humans for nasal breathing only. When exercising (\dot{V}_E greater than 35 L/min), a portion of the inhaled air will enter through the mouth. The ET deposition efficiencies for oral breathing are different from those for nasal breathing and are not recorded in Table G-2. They are, however, included in the computer program as well as proportionality factors defining flow splits between the nose and mouth at higher \dot{V}_E . The additional complexities engendered in the calculation of the ET deposition fraction when both oral and nasal breathing are involved are such that those calculations should not be performed by hand.

Figure G-1 illustrates the relationship between the predicted efficiencies and predicted depositions using this model for the mice. A qualitatively similar set of curves could be produced for any of the other four species. The calculations were made according to the ten steps listed above. The particles were assumed to be monodisperse and the default body weight (BW) for the mice, taken from Table 4-4, was 0.0261 kg. This is the default BW of male BAF1 mice for chronic exposure study durations. Regional deposition efficiencies and fractions were calculated for particles with d_{ae} ranging from 0.5 to 10 μm . These calculated points were connected to produce the smooth curves shown in Figure G-1. The three panels on the left of Figure G-1 are plots of the predicted regional deposition efficiencies; the three panels on the right show the predicted regional deposition fractions derived from the estimated efficiencies and adjusted for inhalability. The vertical axis for the predicted deposition efficiency panels range from 0 to 1. Although the deposition fraction is also bounded by 0 and 1, the vertical axes in the figure are less than 1 in the TB and PU regions. The top two panels of Figure G-1 are the predicted deposition efficiency and fraction, respectively, for the ET region. These two curves are plotted as a function of the impaction parameter described for Equation G-4. The middle two and lower two panels show the predicted deposition efficiencies and fractions for the TB and PU regions, respectively. These four curves are plotted as a function of d_{ae} . When a particle is from a monodisperse size distribution, the d_{ae} and the MMAD are the same. If, however, the particle is from a polydisperse size distribution, the particle can not be described by a single d_{ae} ; the average value of the distribution, the MMAD, must be used. (See Appendix H for further discussion of particle sizing, units, and averaging methods). In the aerodynamic particle size range, the

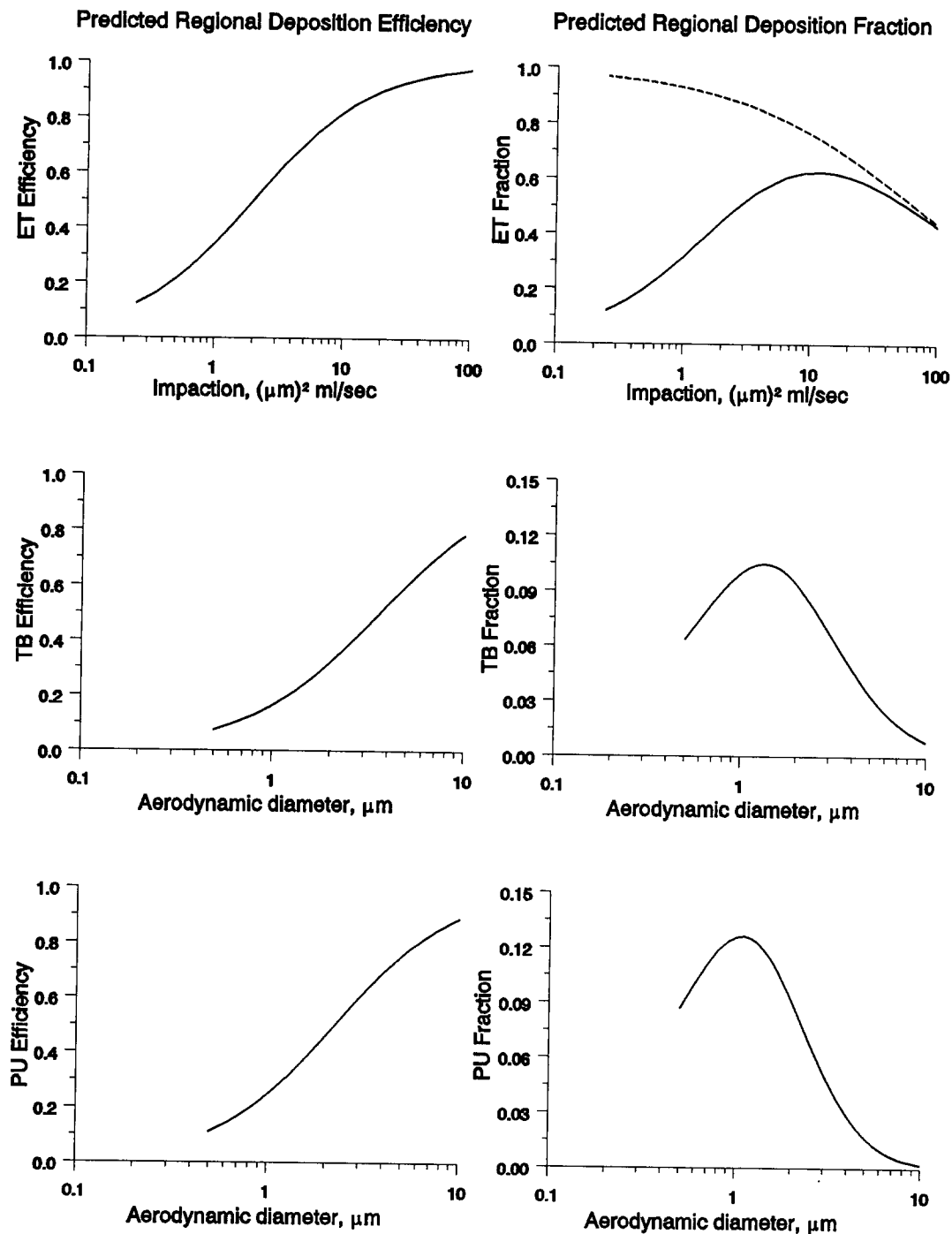

Figure G-1. Comparison of regional deposition efficiencies and fractions for the mouse. A default body weight of 0.0261 kg (from Table 4-4) was used in these calculations. The fractional deposition (solid line) and inhalability (dashed line) are shown in the upper right panel.

deposition efficiency curves all increase monotonically as a function of the independent variable (i.e., either the impaction parameter or d_{ae}) and have both lower and upper asymptotes. The curves describing the deposition fractions, however, have different shapes that are dependent on the respiratory tract region. Deposition fractions in all three regions are nonmonotonic—initially increasing as a function of particle size but decreasing as particle sizes become larger. This is because particles that have been deposited in proximal regions are no longer available for deposition in distal regions. As an extreme example, if all particles are deposited in the ET region, no particles are available for deposition in either the TB or PU regions. In the ET region, the nonmonotonic shape for fractional deposition is due to the fact that not all particles in an ambient concentration are inhalable.

G.3 POLYDISPERSE PARTICLES

As discussed in Appendix H, particles in an experimental or ambient exposure are rarely all a single size but rather have some distribution in size around an average value. As this distribution becomes greater, the particle is said to be polydisperse. Panel A of Figure G-2 illustrates the range of particle sizes from a distribution that is approximately monodisperse ($\sigma_g = 1.1$) and particles that come from a lognormal highly polydisperse distribution ($\sigma_g = 3.0$), although both distributions have the same MMAD of $4.0 \mu\text{m}$. Also drawn in Panel A of Figure G-2 is a vertical line through the MMAD that represents the extreme case of $\sigma_g = 1.0$, that is, an exact monodisperse particle distribution in which all particles are a single size, which is also the MMAD.

The empirical model described in this appendix was developed from exposures using essentially monodisperse particles (which are treated as though they are exactly monodisperse). It is therefore possible to multiply the particle size distribution function (which is customarily considered to be the lognormal distribution) by the predicted depositions (calculated as described in Equations G-8 through G-10) and integrate over the entire particle size range (0 to ∞). Mathematically, this calculation is performed as described by Equation G-3, and is illustrated for the mouse and human ET regions in panels B and C respectively, of Figure G-2.

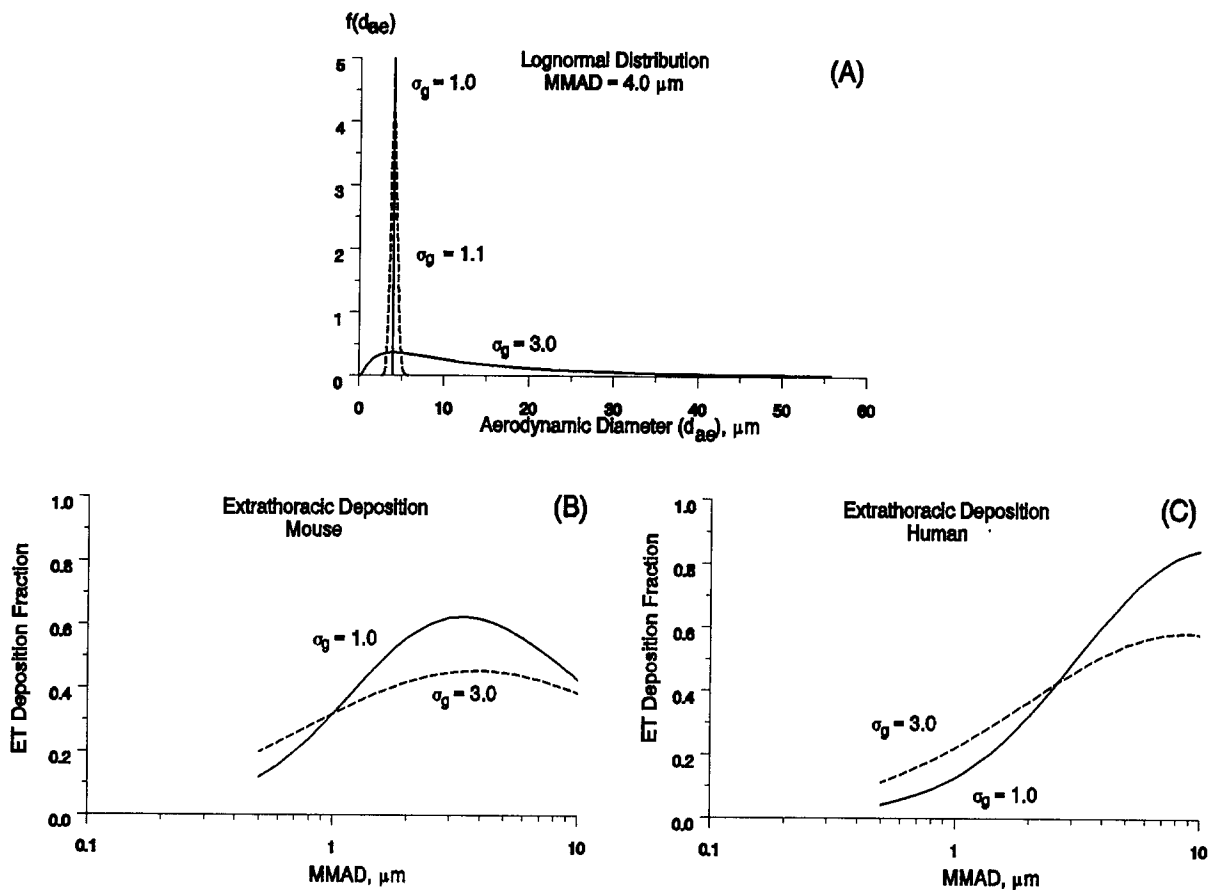

Figure G-2. Range of particles for lognormal distributions with same MMAD but differing geometric standard deviations (A). Effect of polydisperse particles on predicted extrathoracic deposition fractions in mice (B) and humans (C).

$$[\hat{F}_r]_p = \int_0^{\infty} [\hat{F}_r]_m \times \frac{1}{d_{ae}(\log \sigma_g) \sqrt{2\pi}} \times \exp \left[-1/2 \frac{(\log d_{ae} - \log \text{MMAD})^2}{\log \sigma_g} \right] dd_{ae} \quad (\text{G-13})$$

where \log refers to the natural logarithm, $[\hat{F}_r]_p$ is the predicted polydisperse fractional deposition for a given MMAD, and $[\hat{F}_r]_m$ is the predicted monodisperse fractional deposition for particles of size d_{ae} . The limits of integration are defined from 0 to ∞ but actually include only four standard deviations (99.95% of the complete distribution). For each particle size in the integration, $[\hat{F}_r]_m$ is calculated as described in the ten steps listed in this appendix, then

multiplied by the probability of observing a particle of that size in a particle size distribution with that MMAD and σ_g .

Panels B and C of Figure G-2 illustrate one of the principal effects of polydisperse particle size distributions on predicted deposition fractions in the ET region, which is to flatten the deposition curve as a function of MMAD. This same effect is observed also in the TB and PU regions. (Note that the curves in panels B and C are expressed as a function of MMAD. They were generated as a function of the impaction parameter but are expressed as a function of MMAD for ease of comparison between species. A \dot{V}_E of 37.5 mL/min was used for the mouse and of 13.8 L/min for the human.) Rudolf and colleagues (1988) have also investigated the effect of polydisperse particle size distributions on predicted regional uptake of aerosols in humans and present a more detailed discussion of these and related issues.

G.4 REGIONAL DEPOSITED DOSE RATIO CALCULATIONS IN RATS AND HUMANS: AN EXAMPLE

Three respiratory tract $RDDR_r$ values were calculated as described by Equation 4-7 using (1) the default body weight for a female Fischer 344 rat in a subchronic study from Table 4-5 to estimate \dot{V}_E for the rat and (2) the regional respiratory tract surface areas as the normalizing factor for the rat and human from Table 4-4. In Figure G-3, the ET, TB, and PU $RDDR_r$, as a function of particle size, for particles in the aerodynamic size range are compared for monodisperse and a highly polydisperse particle size distribution ($\sigma_g = 3.0$). When the $RDDR_r$ is 1, both human and rodent would be predicted to have a comparable dose rate per unit surface area of the inhaled particles. Ratios with a value of less than 1 indicate that for an equivalent external exposure concentration, the dose rate per unit surface area in the human will be greater than in the rodent; while $RDDR_r$ which are greater than 1 occur when the rodent receives a larger surface area adjusted dose rate than the human. Figure G-3 indicates that in the ET region, the human will be expected to have a higher dose rate per unit surface area than the rat over the aerodynamic particle size range for both monodisperse and polydisperse particle size distributions. For the highly polydisperse particle size distribution, the $RDDR_r$ in the ET region is relatively constant as a function of aerodynamic

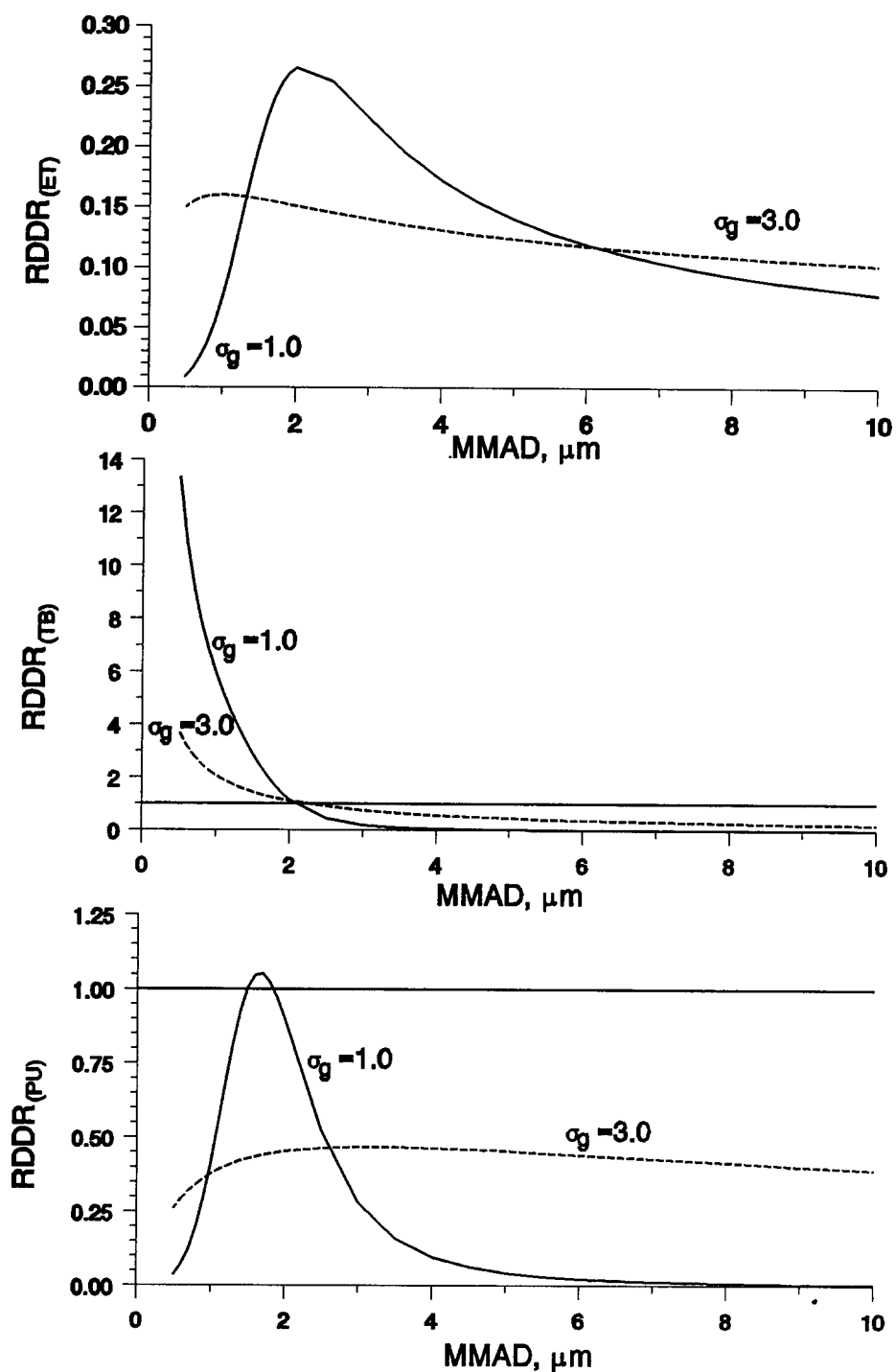

Figure G-3. Regional deposited dose ratios (RDDR_r) for rat:human as a function of mass median aerodynamic diameter (MMAD) for monodisperse ($\sigma_g = 1$) and polydisperse ($\sigma_g = 3$) particle size distributions.

particle size. This may be interpreted to mean that for a highly polydisperse size distribution, the dose rate per unit surface area to the ET region of the human will be approximately 10 to 15 times that to the ET region of the rat regardless of the particle MMAD. In the TB region, the RDDR declines over the aerodynamic particle size range for both mono- and polydisperse particle size distributions. For particles smaller than about 2 μm MMAD, the rat is predicted to have a higher dose rate than the human; for larger particles, the relationship is reversed. In the PU region, a relationship that is qualitatively similar in shape to the RDDR_{ET} is observed; however, the range of the RDDR_{PU} is much larger and there is a suggestion that the dose rate in the rat is greater than that in the human for particles of about 2 μm MMAD since the $\text{RDDR}_{\text{PU}} > 1.0$.

This example illustrates the complexities in the relationships between dose rate per unit surface area in the three respiratory tract regions for rodents and humans. The regional differences as well as the differences due to MMAD and σ_g indicate the importance of replacing administered dose with dosimetric information whenever possible in making risk evaluations.

APPENDIX H

PARTICLE SIZING CONVENTIONS

Solid or liquid particles suspended in a gas are called an aerosol. In toxicological experiments and epidemiological studies, aerosol particles from a given exposure are commonly described by some measure of the average size of the particle and some measure of variability in that average size. Although the average size is usually expressed as a diameter, there are numerous methods for calculating diameter. In this appendix, some of the more common sizing conventions for spherical (or nearly spherical) particles are briefly discussed. Conversions from reported units to the units required to use the particle dosimetry model described in this document are provided. More detailed discussions of particle properties and behavior may be found elsewhere (Raabe, 1971, 1976; Hinds, 1982).

H.1 GENERAL DEFINITIONS

Particles in an exposure are rarely all a single size but rather have some distribution in size around an average value. It is generally accepted (Raabe, 1971) that the lognormal distribution provides a reasonable approximation for most observed spherical particle distributions. For this reason, particle exposures are frequently characterized by median diameter and the geometric standard deviation (σ_g). Statistically speaking, data from a lognormal distribution may be completely described by the median and geometric standard deviation. As σ_g approaches 1.0, the distribution of the particles approaches a single size and the particles are said to be monodisperse. As a matter of practicality, a distribution is considered to be near monodisperse when σ_g is less than 1.3. As σ_g approaches infinity, the distribution contains particles of many sizes and is said to be polydisperse. By definition, σ_g cannot be less than 1.0.

In toxicological experiments, researchers might use (or try to use) monodisperse spherical particles because deposition is a function of particle size. Real world exposures, however, are rarely to monodisperse particles. Accordingly, laboratory animal experiments

designed to mimic some real exposure will use polydisperse particle distributions. Studies of diesel exhaust and of Mt. St. Helens volcanic ash, for example, used highly polydisperse particles. In addition to being polydisperse, such particles also have irregular shapes. Although some irregular particles may be described by their aerodynamic diameter and so be considered to behave like spherical particles, other particles have such extreme differences in shape that they must be described by other parameters. Fibers are one extreme example of nonspherical particle shapes. Deposition fractions for these particles may not be calculated with the particle dosimetry model used in the methodology.

Particle diameters are most frequently reported as geometric diameter (d_g) or aerodynamic diameter (d_{ae}). Aerodynamic diameter is defined as the diameter of a unit density sphere having the same settling velocity as the geometric diameter of the particle in question. Geometric diameters may be converted to aerodynamic diameters according to the following equation:

$$d_{ae} = d_g \sqrt{\rho C(d_g)/C(d_{ae})} \approx d_g \sqrt{\rho}, \quad (\text{H-1})$$

where ρ is the particle density in g/cm^3 and $C(d)$ is the Cunningham slip correction factor.

The particle dosimetry model requires that the particle size be expressed in aerodynamic diameter so studies reporting particle sizes in these units will most likely not require any further conversion. There are, however, two commonly used definitions for d_{ae} ; the methodology uses the definition of the Task Group on Lung Dynamics (1966). Because of the complexities in calculating d_{ae} by the Task Group equation, other investigators have developed an alternate specification for aerodynamic diameter (Mercer et al., 1968; Raabe, 1976). This d_{ae} is called an aerodynamic resistance diameter, d_{ar} , and may be converted to d_{ae} according to the following equation:

$$d_{ae} = (d_{ar}^2 + 0.0067)^{0.5} - 0.082. \quad (\text{H-2})$$

Summary information from an exposure will most often be presented as count (CMD), mass (MMD), surface (SMD) or activity (AMD), median (geometric) diameter. The summary information might be reported in terms of median aerodynamic diameters instead (CMAD, MMAD, SMAD, AMAD).

Because the particle distributions are assumed to be lognormal, estimation of count, surface area, or mass distributions for any given sample of particles may be made once one of those distributions has been measured. Figure H-1 shows a typical log-normal distribution and the various indicated diameters encountered in inhalation toxicology literature. Table H-1 provides the definitions of these diameters. A series of conversion equations originally derived by Hatch and Choate (1929) may be used to convert the reported units to MMAD, the units required by the particle dosimetry model. Figure H-2 shows the same aerosol as in Figure H-1 plotted on log-probability paper and illustrates the various size parameters that can be computed using the Hatch-Choate equations. The relevant conversion equations are summarized in Table H-2. It is a characteristic of any weighted distribution of a lognormal distribution (such as the conversions described in Table H-2) that the geometric standard deviation will be unchanged.

Conversion of activity median diameter (AMD) to MMAD depends on how the radiolabeling of the particle was done. If the label was generated in a liquid, then the label is distributed throughout the volume of the particle and the AMAD may be considered to be equivalent to the MMAD. If, however, the radioactivity was attached to the surface of the particle, then the activity median diameter may be considered to be proportional to the surface area median diameter. More information on the labelling procedure is required to provide an estimate of the proportionality factor. Further discussion of issues related to activity diameters may be found elsewhere (Hofmann and Koblinger, 1989).

The concept of activity diameter is also useful when considering the physical characteristics of particles that are responsible for the health effect or toxicity of concern. The activity diameter of a particle may be the most appropriate expression of size for this purpose. This expression takes into account the "activity" of the physical property of the particle. For example, if the toxicant is distributed only on the surface, then the activity median diameter is equal to the surface median diameter; and conversions to MMAD would

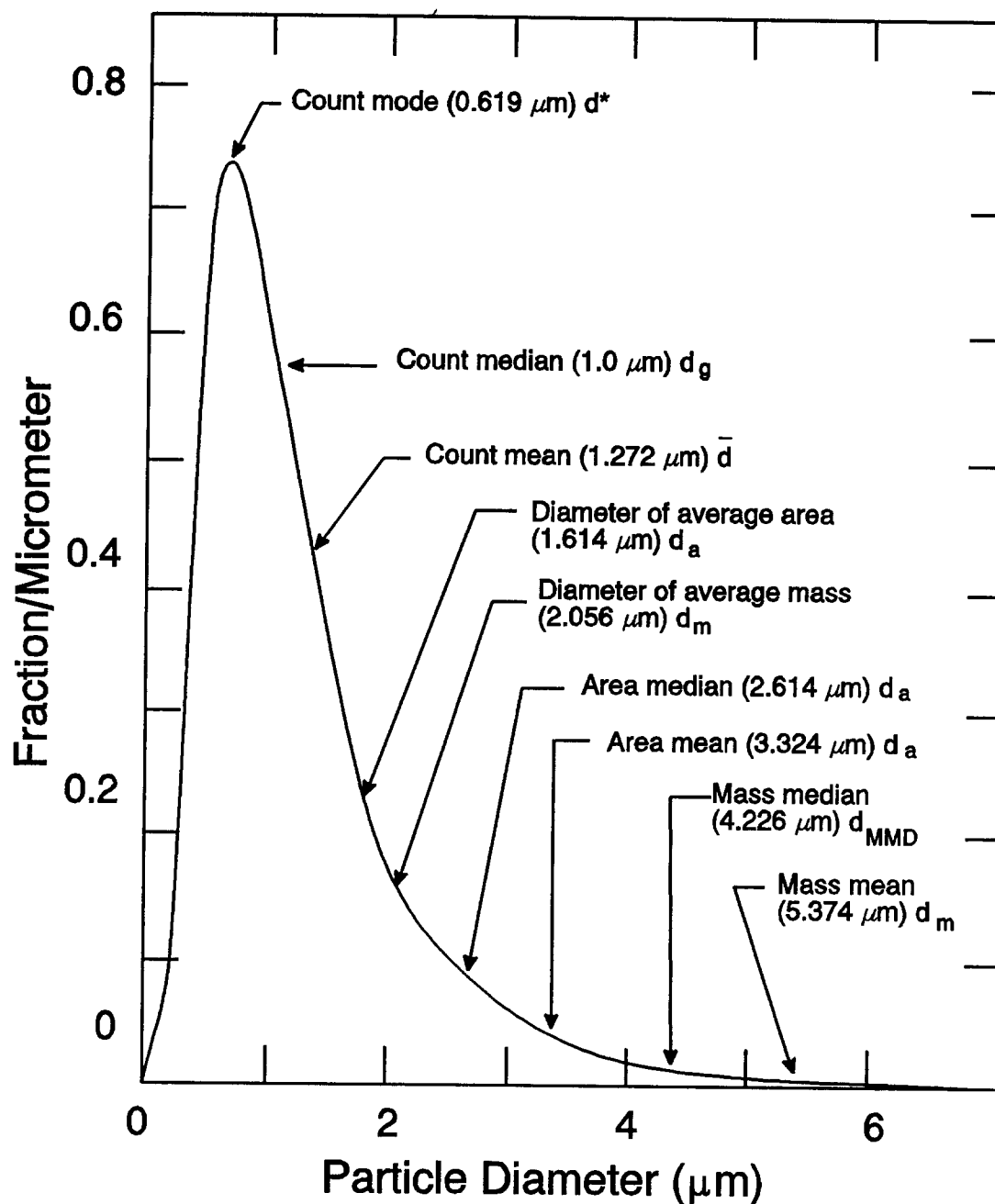

Figure H-1. An example of the log-normal distribution function of an aerosol. Definitions of diameters commonly used are provided in Table H-1. Note that if aerodynamic diameters were being measured, then count or other frequency distribution would be measured against that (e.g., count median aerodynamic diameter [CMAD]).

Source: Orr and Keng (1976).

TABLE H-1. PARTICLE DIAMETER DEFINITIONS

Count mode diameter	The most frequently characterized particle diameter. In Figure H-1, the frequency is normalized to frequency (or number) per micron. This type of graph is also used in analyzing cascade impactor data.
Count median diameter	This diameter is used to describe any log-normal distribution. It is the diameter of a particle that is both larger and smaller than half the particles sampled.
Count mean diameter	The average particle diameter. It is calculated by first multiplying each diameter measured by the number of particles having that diameter. Summing all of these products over the entire range of diameters measured and dividing by the total number of particles sampled gives the count mean diameter.
Diameter of "average mass"	Another average particle diameter related to the total mass of particles sampled. The mass of the particle of "average mass" multiplied by the total number of particles sampled, equals the total mass of particles sampled. The total mass of particles sampled is calculated by first multiplying the single-particle mass calculated for each diameter measured by the number of particles having that diameter and summing all of these products over the entire range of diameters measured. The average mass of each individual particle sampled is obtained by dividing this number by the total number of particles. The diameter is calculated by assuming a sphere and applying the density of the material to convert from mass to volume and then to diameter.
Mass median diameter	Diameter of the particle having a mass that is both larger and smaller than the mass of half the particles sampled.
Mass mean diameter	Average particle diameter, calculated by first multiplying each diameter measured by the cumulative mass of all particles having that diameter. Summing all of these products over the entire range of diameters measured and dividing by the total mass of the particles sampled gives the mass mean diameter.

Source: Moss and Cheng (1989).

be the same as described above for radiolabeled activity. If the toxicant is soluble, the surface area of the particle will influence the rate of dissolution because solubilization occurs at the surface. Such a situation needs to be understood more thoroughly, especially for complex particles.

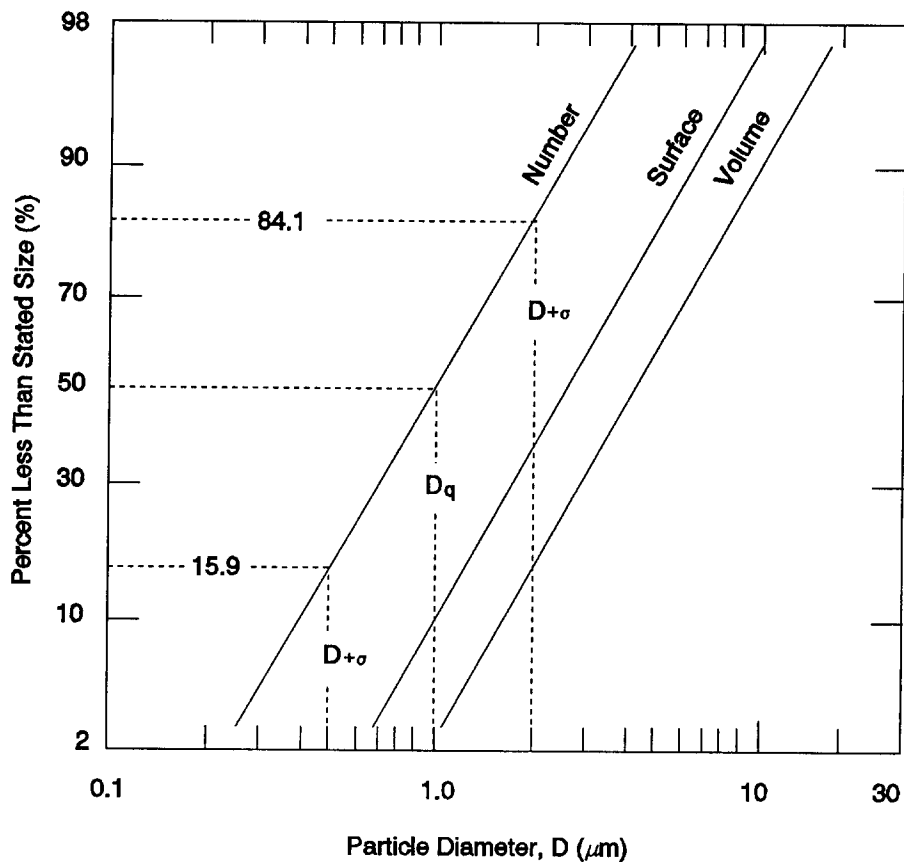

Figure H-2. Plot of same aerosol as in Figure H-1 on log-probability paper. The curves illustrate the various size parameters that can be computed using the Hatch-Choate equations.

Source: Marple and Rubow (1980).

H.2 GENERATION SYSTEMS AND CHARACTERIZATION INSTRUMENTS

Aerosols may be generated by condensation of vapors, by dispersion of dry particles or liquids, or by dispersion of a suspension of solids in a liquid. Each of the currently available systems and applied techniques used to generate test atmospheres for inhalation toxicology testing have operating specifications that should be evaluated when attempting to determine whether the operating conditions and size range stated was appropriate to the technique and to ascertain the probable particle size range. The operating specifications (pressure, flow rate, output concentrations, particle diameters, and standard deviations) of various generation

**TABLE H-2. LOGNORMAL CONVERSION EQUATIONS FOR
COMMON TYPES OF DIAMETERS**

Count to Mass

$$\text{MMAD} = \text{CMAD} \exp (3 [\log \sigma_g]^2)$$

$$\text{MMAD} = \rho^{0.5} \text{CMD} \exp (3 [\log \sigma_g]^2)$$

Activity to Mass

MMAD = AMAD if label may be assumed to be distributed throughout volume of particle

MMAD = pSMAD if label is attached to a proportion, p, of the surface of the particle

Count to Surface

$$\text{SMAD} = \text{CMAD} \exp (2 [\log \sigma_g]^2)$$

$$\text{SMAD} = \rho^{0.5} \text{CMD} \exp (2 [\log \sigma_g]^2)$$

Note: log = natural logarithm.

systems have been reviewed elsewhere and can serve as references (Moss and Cheng, 1989; American Conference of Governmental Industrial Hygienists, 1978; Willeke, 1980).

Characterizing test atmospheres includes defining the aerosol concentration, chemical composition, and particle size and shape. Aerosols for toxicology testing should be characterized to quantitate toxicant concentration, stability, and particle size distribution during exposure. Mass concentration of aerosols can be measured directly using filters, impingers, and impactors. Other methods of determining mass concentration include beta-attenuation, piezobalance, and photometers. The latter two instruments are real-time continuous samplers that enable monitoring and early detection of problems related to generation and delivery. Number concentrations are obtained by using nucleus counters, optical counters, electrical counting, and microscopy.

The shape and size of particles are determined by collecting particles on filters, on grids mounted on thermal or electrostatic precipitators or by microscopy. Dynamic size measurements made using inertial or mobility aerosol instruments are frequently used to determine the aerodynamic and mobility equivalent diameters. These diameters can be used in the conversions scenarios provided in the next section.

Inertial types of instruments are used to measure d_{ae} larger than about 0.5 μm . For particles less than 0.5 μm in diameter, most inertial instruments are not effective in

separating and measuring particle size. In these cases, the mobility type of aerosol instrument is used. The mobility equivalent diameter determines the collection efficiency in many processes that are controlled by the diffusion deposition mechanism. Two types of mobility instruments are the electrical aerosol analyzer (EAA) and the diffusion batteries. No single instrument can measure aerosol size distributions of particles with diameters from 0.005 to 10 μm . Sometimes different exposure levels are generated or characterized with different instruments. Careful analysis of data is required, because the inertial instruments (e.g., cascade impactor) give mass distribution, and the EAA and screen diffusion battery give number distribution. Figure H-3 shows the measurement ranges of aerosol monitoring instruments. Knowledge of the measurement range of the instruments used to characterize the test atmosphere can be useful in determining the probable particle size range used in a given study.

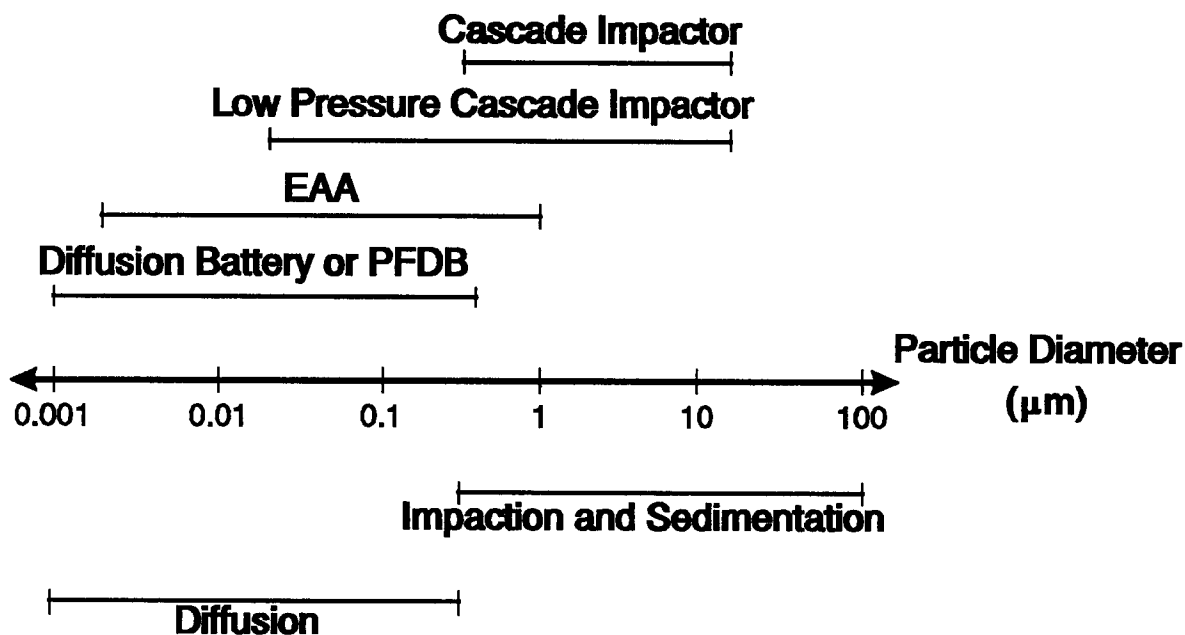

Figure H-3. Measurement ranges of aerosol monitoring instruments.

Source: Moss and Cheng (1989).

H.3 CONVERSION SCENARIOS

Particle information reported in a study will most likely fall into one of the seven categories defined below. The remainder of this appendix describes these seven possibilities and outlines appropriate strategies to convert reported particle information to MMAD, required to run the particle dosimetry model.

1. MMAD and σ_g .

In this case the information in the study has been reported in the units required for analysis, and no conversions or changes are required to run the model.

2. A median diameter and σ_g .

Conversions from the most commonly used medians to MMAD are provided in Table H-2. No conversions are required for σ_g .

3. A median diameter and a range of particle sizes.

The variance, σ_g , may be estimated as

$$\begin{aligned}\sigma_g &= \exp \left[\frac{\log(\text{median}/\text{lower bound})}{n} \right] \\ &= \exp \left[\frac{\log(\text{upper bound}/\text{median})}{n} \right]\end{aligned}\tag{H-3}$$

where log is the natural logarithm, exp is the irrational number, e, raised to the power in the brackets, and the range falls between the reported upper and lower bounds. The range will include some percentage of the particles that is reflected in the parameter n, the number of standard deviations used in calculating σ_g (Table H-3). The median diameter may then be converted to MMAD according to the equations in Table H-2, if necessary.

TABLE H-3. PERCENTAGE OF PARTICLES IN THE REPORTED RANGE ASSOCIATED WITH THE NUMBER OF STANDARD DEVIATIONS (n) USED TO CALCULATE THE GEOMETRIC STANDARD DEVIATION

Percentage of Particles in the Reported Range	n
0.68	1
0.95	2
0.997	3
>0.999	4

4. A median diameter only.

An estimate of σ_g must be derived from outside sources. In order of preference, the following sources are recommended.

- a:** Other studies by the same group using the same compound for which the median and σ_g are reported.
- b:** A comparison of the variances reported by other studies for the same compound could be used to determine reasonable bounds on σ_g . Using the largest and smallest σ_g determined by this method, the dosimetry model can be run to determine the sensitivity of the dose ratio to σ_g for this particular particle size and rodent to human comparison.
- c:** The particle size range can be estimated from Figure H-4 and σ_g calculated according to Equation H-3 and Table H-3 (letting $n = 4$). If necessary, the median can then be converted to MMAD according to Table H-2.

5. A range of particle sizes is the only information provided.

A median, in the same units as the reported particle size range, must be estimated from outside sources. In order of preference, the following sources are recommended.

- a:** Other studies by the same group using the same compound for which the median is reported.
- b:** A comparison of the medians reported by other studies for the same compound could be used to determine reasonable bounds on the median. If necessary, the dosimetry model could be run using the largest and smallest medians estimated by

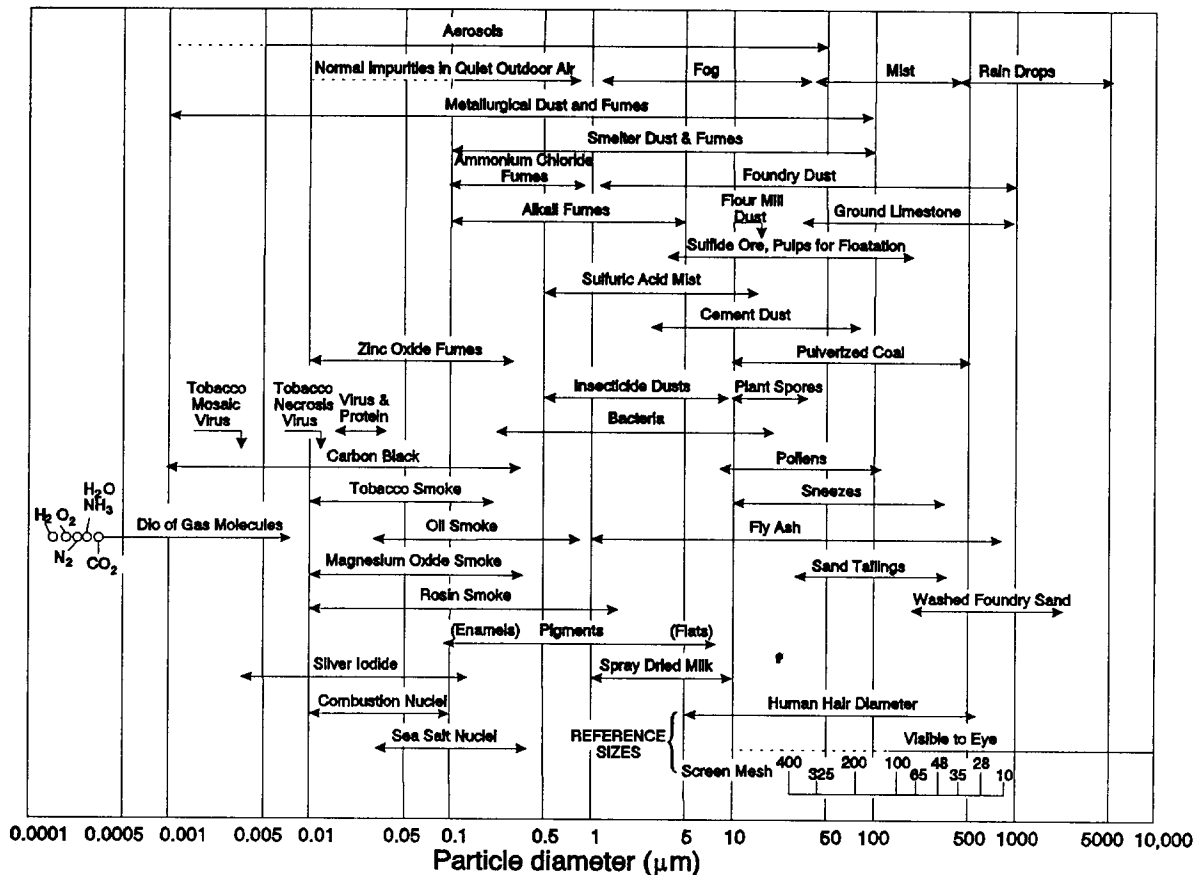

Figure H-4. Various airborne materials and their size ranges.

Source: Hatch and Gross (1964).

this method. Note that running the model with alternate estimates of the median will require alternate estimates of σ_g .

Using the estimated median and the range of particle sizes, σ_g may be estimated as described above in scenario 3. Finally, the median diameter may be converted to MMAD according to the equations in Table H-2, if necessary.

6. Descriptive information on particle size is the only information provided.

Some of the more commonly used expressions of particle characteristics and the generally accepted particle sizes associated with these characteristics are shown in Table H-4. Further information on ranges of sizes for some common classifications of

TABLE H-4. GENERAL PARTICLE DESCRIPTIONS AND ASSOCIATED SIZES

Particle Description	Size (μm)
Coarse	> 2.5
Fine	< 2.5
Fumes, Smoke	< 1
Fog, Mist	< 1 → 20

particles may be found in Figure H-4. Using this information, the median may be estimated as described in scenario 5, and σ_g estimated as described in scenario 4.

7. No information on particle sizes provided.

Studies that do not provide this information should be suspect for deficient quality. Some of the older toxicology literature may not provide this information, however, and a default value may need to be invoked. The first approach in this situation is to attempt an estimate of particle size and distribution based on the generation apparatus used. Operating specifications of various generation systems are available from the manufacturer or reviewed elsewhere (Moss and Cheng, 1989; American Conference of Governmental Industrial Hygienists, 1978; Willeke, 1980). In conjunction with this information, the knowledge that prior to the late 1970s, the generation technology was not sufficiently sophisticated to deliver consistent exposures of particle sizes above 3 μm (MMAD) can be used to construct a default approach. The recommended default approach is to use the MMAD and σ_g characteristic for the given generation system that is $\leq 3 \mu\text{m}$ and that yields the smallest (i.e., most conservative) RDDR values for the respiratory tract region of interest. Knowledge of the measurement range of the instrument used to characterize the test atmosphere can also be used to estimate a particle size. Figure H-3 provides the measurement ranges of some aerosol monitoring instruments.

The second approach is to use particle size information from other studies to estimate the particle characteristics for the exposure in question. If no such information is available, Figure H-4 provides the general size ranges for most common classifications of particles. Using this information, the median may be estimated as described in scenario 5, and σ_g estimated as described in scenario 4.

APPENDIX I

DERIVATION OF AN APPROACH TO DETERMINE HUMAN EQUIVALENT CONCENTRATIONS FOR EFFECTS OF EXPOSURES TO GASES IN CATEGORIES 1 AND 2

As discussed in Sections 3.2 and 4.3, the optimal approach to describe regional respiratory tract dose for extrapolation across species is to use a comprehensive dosimetry model. The limited number of sophisticated dosimetry models that currently exist are either chemical-specific or class-specific and require an extensive number of model parameters. As discussed in Section 3.2, the chemical-specific or class-specific nature of these models has been dictated by the physicochemical properties of the subject gases and therefore any single resultant model is not applicable to the broad range of physicochemical properties of gases (or vapors—herein referred to as gases) that this methodology is aimed at addressing. In addition, sufficient data from which to estimate model parameters for each gas are often unavailable.

A conceptual framework was thus developed to structure mathematical models that require limited gas-specific parameters and that may be further reduced by simplifying assumptions to forms requiring minimal information. The models in reduced form are the basis of the default adjustments used in Section 4.3 and are used to estimate the human equivalent concentrations (HECs) from no-observed-adverse-effect levels (NOAELs) of gases when the lack of data for the required parameters precludes more comprehensive modeling. This appendix provides the conceptual framework and background details of the default derivation for the adjustments used in Section 4.3.

Because adverse respiratory effects may be observed in the extrathoracic (ET), tracheobronchial (TB), or pulmonary region (PU), the conceptual framework is constructed to derive a regional description of dose, defined as the regional absorption rate. The regional absorption rate is used as a surrogate of regional dose and is assumed to represent the

effective dose for evaluation of the dose-response relationship. The physicochemical properties such as the water solubility and reactivity (e.g., ionic dissociation or tissue metabolism) of the gas in the respiratory system are major determinants of the regional absorption rate. For example, styrene is relatively insoluble in water and unreactive with the respiratory tract surface liquid and tissue. This gas is therefore absorbed primarily in the lung periphery, where it partitions across the blood-gas barrier. Formaldehyde, however, is both water soluble and reactive such that most of the gas is absorbed in the ET region. The concept of differentiating gases based on their stability, reactivity, or tissue metabolic activity has been proposed by Dahl (1990) who presented a methodology to assist in categorizing gases. As discussed in Section 3.2, delineation of the categories is accomplished by identifying dominant mechanistic determinants of absorption that are based on the physicochemical characteristics of the gases. The dominant mechanistic determinants are used to construct a conceptual framework that directs development of the dosimetry model structures.

The categorization scheme discussed in Section 3.2 and developed more fully herein is used to establish a dosimetry model structure for three categories of gases from which default equations are developed by imposing additional simplifying assumptions. Model structures for two of the three categories are developed in this Appendix. The structure for Category 3 gases is developed in Appendix J. Gases in Category 3 are relatively water insoluble and unreactive in the ET and TB surface liquid and tissue and thus exposures to these gases result in a relatively small dose to these regions. The uptake of these gases is predominantly in the PU region and is perfusion limited. The site of toxicity of these gases is generally remote to the principal site of absorption in the respiratory tract. Thus, the relatively limited dose to the ET and TB regions does not appear to result in any significant ET or TB respiratory toxicity. Toxicity may, however, be related to recirculation. An example of a Category 3 gas is styrene. Gases that fall in Category 3 are modeled using the structure and default equations presented in Appendix J.

The methodology developed in this appendix addresses the absorption of gases that are relatively water soluble and/or reactive in the respiratory tract (Categories 1 and 2 of the scheme described in Section 3.2). The focus here is on the description of dose for respiratory tract effects. This is not to suggest that the toxicity is limited to the respiratory

regions and in fact, for Category 2, the model structure may be used to define a dosimetric for remote toxicity because this category of gases has physicochemical characteristics that may result in some systemic circulation of toxicant. The assumption of this modeling approach is that the description of an effective dose to each of these regions for evaluation of respiratory effects must address the absorption or "scrubbing" of a relatively water soluble and/or reactive gas from the inspired airstream as it travels from the ET region to the PU region. That is, the dose to the distal regions (TB and PU) is affected by the dose to the region immediately proximal. The appropriateness of assessing proximal to distal dose representative of the scrubbing pattern is supported by the often observed proximal to distal progression pattern of dose-response for respiratory tract toxicity with increasing concentration. At low concentrations of relatively water soluble and/or reactive gases, observed effects are isolated to the ET region. At higher concentrations, more severe effects occur in the ET region and toxicity is also observed to progress to the distal regions. The intensity or severity of the distal toxicity also progresses with increased exposure concentrations.

In the following section, the conceptual framework that directs development of dosimetry models is discussed. The framework is constructed according to the categorization scheme of gases based on physicochemical characteristics. The physicochemical characteristics are used to define dominant mechanistic determinants of absorption and thereby determine the mathematical model structure to describe regional dosimetry. The model structures developed in the framework rely on models that are currently in use; a detailed review of potential structures is presented elsewhere (Ultman, 1988) and some are incorporated here. Description and derivation of the model structure for each category of gas follows with the exception of gases that are relatively insoluble in water (Category 3). The uptake of Category 3 gases is predominantly perfusion-limited and the dosimetry approach for these is discussed in Appendix J. Thus, the focus of this appendix is on those gases that are relatively water soluble and/or reactive in the respiratory tract. It should be noted that the definition of reactivity includes both the propensity for dissociation as well as the ability to serve as substrate for metabolism in the respiratory tract. The default equations are derived after the development of the modeling structure for gases in Categories 1 and 2. These equations result from the application of further simplifying assumptions necessary to reduce

the required parameters to perform the dosimetry adjustment when minimal data are available.

I.1 Conceptual Framework

Extrapolation of the dose-response relationship from laboratory animals to humans is performed based on the absorption in the three respiratory tract regions as defined in Chapter 3: extrathoracic (ET), tracheobronchial (TB), and pulmonary (PU). Although toxic effects may sometimes be observed in a more local area within those regions (e.g., the olfactory epithelium of the ET region), the parameters required to further subdivide the description of dose within these regions are not available currently. Several active areas of investigation, such as the evaluation of regional mass transport within the nasal cavity to create maps of localized flows in rats and monkeys (Kimbell et al., 1993), of regional mass transport in the human (Lou, 1993), and of metabolic activity of localized tissues in rodents (Bogdanffy et al., 1986, 1987, 1991; Bogdanffy and Taylor, 1993; Kuykendall et al., 1993), are anticipated to provide the data required to estimate the necessary parameters on a species-specific basis.

The conceptual framework used to direct development of model structures for estimation of regional gas dose is based on the categorization scheme presented in Section 3.2.2. This categorization scheme is based on the physicochemical characteristics of water solubility and reactivity as shown in Figure I-1. These characteristics are used to define dominant mechanistic determinants of absorption and thereby direct development of model structures. As will be described, the modeling structure favored for this development has been used extensively to quantify gas exchange or absorption of pollutants. This structure is in no way promoted exclusively as the only one available; it is however used here to develop the approach for dosimetric adjustment. Its application to each category will be presented and the default equations for use with limited parameters will be derived.

I.1.1 Category Scheme for Gases with Respiratory Effects

This appendix focuses on those gases that are relatively water soluble and/or reactive in the respiratory tract (i.e., those gases in Categories 1 and 2, initially defined in Section 3.2).

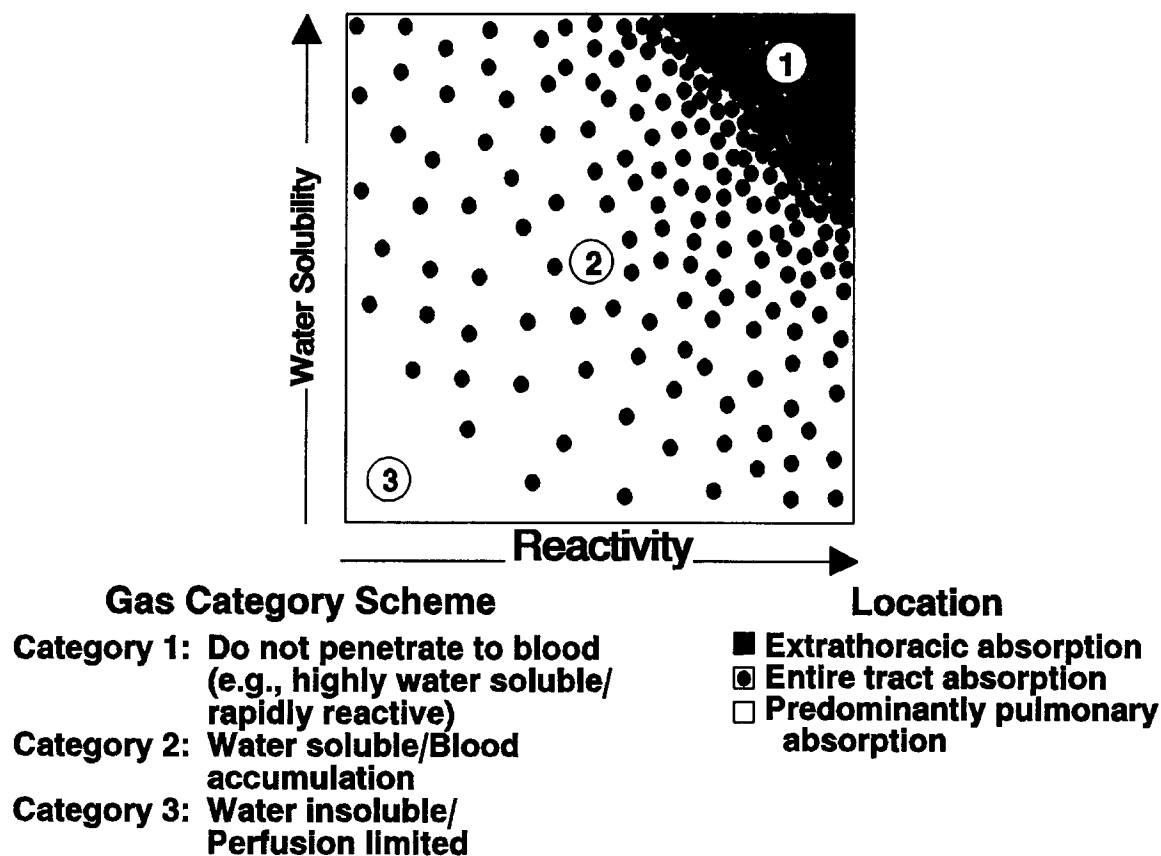

Figure I-1. Gas categorization scheme based on water solubility and reactivity as major determinants of gas uptake. Reactivity is defined to include both the propensity for dissociation as well as the ability to serve as substrate for metabolism in the respiratory tract. Definitive characteristic of each category and anticipated location (region) for respiratory tract uptake are shown.

Those gases which are relatively insoluble in water, principally absorbed in the PU region, and distributed remote to the respiratory tract (Category 3) are addressed in Appendix J. There are two points of departure between the treatments of Appendix I versus Appendix J: (1) uptake of Category 1 and 2 gases (Appendix I) is limited by absorption in the gas or surface-liquid/tissue phase, whereas uptake to the blood from the airspace for gases in Category 3 (Appendix J) is described by the blood-to-air partition coefficient only; and (2) Appendix I considers absorption in the regions proximal to the PU region.

Two categories of gases with potential respiratory effects at the uptake site have been identified for simplifying the methods for dose determination. The categories separate the gases on the basis of the physicochemical absorption parameters and the consequent dominant determinants of absorption. The two categories of gases with potential respiratory effects are (1) highly water soluble and/or rapidly irreversible reactive gases; and (2) water soluble gases and gases that may also be rapidly reversibly reactive or moderately to slowly irreversibly metabolized in respiratory tract tissue.

The gases in Category 1, highly water soluble and rapidly irreversibly reactive, are distinguished by the lack of a blood-phase component to the transport resistance (i.e., almost none of the gas reaches the bloodstream), which allows the overall transport to be described by the transport resistance through air and liquid/tissue phases only (i.e., the two-phase transport resistance model). Examples of gases in this category are hydrogen fluoride, chlorine, formaldehyde, and the volatile organic acids and esters.

Gases in Category 2 are distinguished from those in Category 1 by the potential for accumulation of a significant blood concentration that could reduce the concentration gradient driving the absorption process and thereby reduce the regional absorption rate. In addition, the accumulated blood or surface liquid/tissue concentration may impose a backpressure (i.e., a significant reverse in the concentration gradient) during exhalation which could result in desorption. Category 2 gases may be further subdivided by distinguishing between those that react reversibly with the surface liquid or underlying tissue from those that react irreversibly. A gas that is moderately to slowly irreversibly metabolized in the respiratory tract will effectively reduce tissue concentration and thereby increase the concentration gradient during absorption and decrease it during desorption. In contrast, reversible reactions will not affect the gradient dramatically. Consequently, in the case of irreversible reactions, the reaction rate may need to be included in the model. In the case of Category 2 gases undergoing a reversible reaction, the reaction may be incorporated into the model by the use of an enhanced solubility term. Examples of Category 2 gases are ozone, sulfur dioxide, xylene, propanol, and isoamyl alcohol.

General physicochemical properties of the gases have been used to delineate each of the categories. The boundaries between categories are not definitive. Some compounds may appear to be defined by either Category 1 or Category 2 because water solubility and

reactivity are a continuum. Thus, although sulfur dioxide is reversibly reactive, which would categorize it as a Category 2 gas, it is also highly soluble such as to be a Category 1 gas. Similarly, ozone is highly reactive yet only moderately water soluble. More explicit delineation of the categories will be made upon review of the empirical data and the predictability of the model structures for gases that may appear to fit more than one category. The modeling approach for the determination of dose for each of these categories of gases is discussed separately in the following sections, along with the determination of the default methods if sufficient detail from which to determine dose is not available for a specific gas.

I.1.2 General Model Structure

Numerous model structures have been used to describe toxicant uptake in the respiratory tract. The structures range from compartmental models, such as physiologically based pharmacokinetic (PBPK) models in which spatial details are ignored, to distributed parameter models, such as the finite difference models of McJilton et al. (1972) and Miller et al. (1985). The finite difference models have been applied to specific gases, but a generalized structure was developed by Hanna et al. (1989) for water soluble gases. Several reviews of the various structures are available (Morgan and Frank, 1977; Ultman, 1988, 1994).

Methodologies to describe respiratory uptake of gases have been successfully applied by using two types of empirical compartmental models. These models are distinguished by the gases to which they have been applied. The ventilation-perfusion model first applied to the exchange of carbon dioxide/oxygen (CO_2/O_2) in the lung periphery has been principally and most successfully employed to describe the stable and less soluble gases. The modeling of the respiratory tract using the ventilation-perfusion model has become a central component of PBPK models as described in Appendix J (Ramsey and Andersen, 1984; Andersen et al., 1987a; Overton, 1989; Andersen et al., 1991). In a ventilation-perfusion model (or Bohr model), the mass of inhaled chemical reaching the lung periphery, or PU region, is calculated as the product of the ambient concentration and the alveolar ventilation rate. The ventilation-perfusion model would overpredict the gas concentration that reaches the alveoli if the gas is absorbed or reacts with the ET and TB airway surface liquid and/or tissue.

The second type of model was developed to describe the fraction of an absorbing or reacting gas that penetrates the ET region. This model, which will be referred to as the

penetration fraction model, was first used by Aharonson et al. (1974) to demonstrate empirically the different upper airway absorption efficiencies for gases with differing physicochemical properties. This modeling concept has since been utilized by Kleinman (1984), Morgan and Frank (1977), Ultman (1988), Hanna et al. (1989), Gerde and Dahl (1991), and Morris and Blanchard (1992). A principal focus of these modeling efforts has been to predict the scrubbing efficiency of the ET airway based on the ventilation rate and the physicochemical properties of the gas. However, the general applicability of the penetration model has often been limited by the assumption that the gas blood concentration approaches zero, thereby requiring complete systemic elimination. Retaining the blood concentration in the model allows greater flexibility for inclusion of the reduction in the concentration gradient, which would reduce the absorption rate if the gas were to accumulate in blood.

In this conceptual framework, the methodology to adjust regional respiratory dose from laboratory animals to humans for evaluation of respiratory tract effects is achieved for the relatively water soluble and/or reactive gases (Categories 1 and 2) by integrating the above two types of empirical models. These models have been used extensively and are therefore favored due to their wide use and potential for empirical measurement of model parameters. The penetration fraction model provides estimation of the ET and TB doses. These are used to adjust the mass of inhaled gas reaching the PU region in the ventilation-perfusion model. Additional systemic compartments (e.g., liver and fat) may be required in the model to describe gases that accumulate significantly in the blood. The addition results in a model structure similar to PBPK models; however, it also incorporates the mass transport description of the scrubbing of the gas in the ET and TB regions.

The approach herein to determine the regional dose within the respiratory tract is developed by relying on the overall mass transport coefficient, K_g , to characterize the transport of gases between the airphase, the intervening surface liquid and tissue, and the blood. In the absence of empiric measurement, K_g may be estimated or scaled for a given gas based on its physicochemical properties and reactivity within the respiratory tract. In the following section, a derivation of K_g is provided and the influence of gas physicochemical characteristics on K_g is discussed. The definitions of parameter symbols used in the following sections are provided in Table I-1.

TABLE I-1. DEFINITION OF PARAMETER SYMBOLS USED IN APPENDIX I

a	Airway perimeter (cm^2)
C_0	Initial concentration (mg/cm^3)
C_{av}	Pulmonary region gas concentration (mg/cm^3)
$C_a(x)$	Gas concentration as a function of x (mg/cm^3)
C_b	Blood concentration (mg/cm^3)
$C_{b/g}$	Gas concentration in equilibrium with blood concentration (mg/cm^3)
$C_{b/r}$	Concentration of gas in its chemically transformed (reacted) state (mg/cm^3)
C_f	Concentration in the fat compartment (mg/cm^3)
C_g	Gas phase concentration in airway lumen (mg/cm^3)
C_{gi}	Gas-phase concentration at the interface of the gas phase with the surface-liquid/tissue phase (mg/cm^3)
C_i	Inhaled concentration (mg/cm^3)
C_l	Surface-liquid/tissue phase concentration (mg/cm^3)
C_{LG}	Concentration in the lung compartment (mg/cm^3)
$C_{l/g}$	Surface-liquid/tissue concentration in equilibrium with the gas phase (mg/m^3)
C_{li}	Surface-liquid/tissue concentration at the interface of the gas phase and the surface-liquid/tissue phase (mg/cm^3)
C_s	Imposed concentration (mg/cm^3)
$C_{T/A}$	Concentration of reacted and unreacted gas in arterial blood (mg/cm^3)
$C_{T/V}$	Concentration of reacted and unreacted gas in venous blood (mg/cm^3)
C_z	Concentration in the surface-liquid/tissue phase (mg/cm^3)
CA	Arterial (unoxygenated) blood concentration (mg/cm^3)
CL_{fat}	Clearance from the fat compartment (cm^2/min)
CL_{LV}	Clearance from the liver compartment (cm^2/min)
CL_{SYS}	Clearance from the systemic compartment (cm^2/min)
CV	Concentration in venous (oxygenated) blood entering gas-exchange (PU) region (mg/cm^3)
$CX(\text{EXH})_{ET}$	Concentration exiting from extrathoracic region on exhalation (mg/cm^3)
$CX(\text{EXH})_{PU}$	Concentration exiting from pulmonary region upon exhalation (mg/cm^3)
$CX(\text{EXH})_{TB}$	Concentration exiting from tracheobronchial region upon exhalation (mg/cm^3)
$CX(\text{INH})_{ET}$	Concentration exiting from extrathoracic region upon inhalation (mg/cm^3)
$CX(\text{INH})_{TB}$	Concentration exiting from tracheobronchial region upon inhalation (mg/cm^3)
D	Deposited fraction of mass (unitless)
D_l	Liquid diffusivity (cm^2/min)
dx	Differential of axial distance into airway (cm)
dy	Differential of axial distance into capillary segment (cm)
dz	Differential of distance into the surface-liquid/tissue phase (cm)
\dot{E}_{LG}	Elimination rate in the lung compartment (cm^2/min)
E_{MAX}	Maximum extraction efficiency (unitless)

**TABLE I-1 (cont'd). DEFINITION OF PARAMETER SYMBOLS
USED IN APPENDIX I**

E_T	Liver extraction efficiency (unitless)
erf	Error function (unitless)
ET	Extrathoracic respiratory region
F	Flux fraction (unitless)
fp	Fractional penetration (unitless)
fp_{ET}	Fractional penetration through the extrathoracic region (unitless)
fp_{PU}	Fractional penetration through the pulmonary region (unitless)
fp_{TB}	Fractional penetration through the tracheobronchial region (unitless)
Ha	Hatta number (unitless)
$H_{\text{b/g}}$	Blood:gas (air) partition coefficient (unitless)
H_{EFF}	Effective partition coefficient (unitless)
H_{vb}	Tissue:blood partition coefficient (unitless)
H_{vg}	Surface-liquid/tissue:gas (air) partition coefficient (unitless)
K_g	Overall mass transport coefficient (cm/min)
K_{ET}	Overall mass transport coefficient of the extrathoracic region (cm/min)
K_{PU}	Overall mass transport coefficient of the pulmonary region (cm/min)
K_{TB}	Overall mass transport coefficient of the tracheobronchial region (cm/min)
k_g	Transport coefficient in the gas phase (cm/min)
k_1	Transport coefficient in the surface-liquid/tissue phase (cm/min)
k_{LG}	Elimination rate from lung compartment (min^{-1})
k_m	Alveolar membrane diffusion coefficient (cm/min)
k_r	Reaction rate constant in the blood or tissue (min^{-1})
KM	Michaelis constant (mg/cm^3)
L	Airway length (cm)
M_d	Desorbed mass (mg)
M_{dET}	Desorbed mass from extrathoracic region (mg)
M_{dPU}	Desorbed mass from pulmonary region (mg)
M_{dTB}	Desorbed mass from tracheobronchial region (mg)
\dot{M}_{ET}	Mass flux from extrathoracic region to blood ($\text{mg}/\text{cm}^2\text{-min}$)
\dot{M}_{PU}	Mass flux from pulmonary region to blood ($\text{mg}/\text{cm}^2\text{-min}$)
\dot{M}_{TB}	Mass flux from tracheobronchial region to blood ($\text{mg}/\text{cm}^2\text{-min}$)
N	Overall transport or flux ($\text{mg}/\text{cm}^2\text{-min}$)
N_g	Flux through the air phase ($\text{mg}/\text{cm}^2\text{-min}$)
N_1	Flux through the surface liquid-tissue phase ($\text{mg}/\text{cm}^2\text{-min}$)
PU	Pulmonary respiratory tract region
\dot{Q}_{alv}	Alveolar ventilation rate (cm^3/min) [†]

**TABLE I-1 (cont'd). DEFINITION OF PARAMETER SYMBOLS
USED IN APPENDIX I**

\dot{Q}_b	Local blood flow rate (cm^3/min) [†]
\dot{Q}_r	Cardiac output (cm^3/min) [†]
RGD	Regional gas dose ($\text{mg}/\text{cm}^2\text{-min}$)
RGDR_{ET}	Regional gas dose ratio for the extrathoracic region (unitless)
RGDR_{PU}	Regional gas dose ratio for the pulmonary region (unitless)
RGDR_{TB}	Regional gas dose ratio for the tracheobronchial region (unitless)
SA	Surface area of unspecified respiratory region (cm^2)
SA_{ET}	Surface area of the extrathoracic region (cm^2)
SA_{TB}	Surface area of the tracheobronchial region (cm^2)
SA_{PU}	Surface area of the pulmonary region (cm^2)
S_p	Blood perfusion surface area (cm^2)
t	Time (min)
t_{EXH}	Time (duration) of exhalation (min)
TB	Tracheobronchial respiratory tract region
\dot{V}	Volumetric flow rate (mg/min)
V_b	Capillary blood volume (cm^3)
V_{LG}	Lung compartment volume (cm^3)
VMAX	Maximum velocity of saturable (Michaelis-Menton) metabolism path ($\text{mg}/\text{cm}^2\text{-min}$)
\dot{V}_E	Minute volume (cm^3/min) [†]
x	Distance into the airway (cm)
Δy	Thickness of the surface liquid-tissue layer (cm)
z	Distance into the surface-liquid/tissue phase (cm)
Δz	Surface-liquid/tissue phase thickness (cm)

[†] 1 mL = 1 cm³, so cm³/min = mL/min.

Also note that concentrations are expressed as mg/cm³ (1 mg/cm³ = 10⁻⁶ mg/m³).

I.1.3 Overall Mass Transport Coefficient

The concept of the overall mass transport coefficient is based on a concentration gradient analysis similar to Fick's Law of Diffusion and is utilized to describe transport through several different phases such as air and liquid. The structure of the two-phase mass transport resistance model simplifies the description of mass transport to a minimal number of parameters that may be scaled to gases differing in their physicochemical properties as described later. The more definitive evaluation of transport is to describe absorption by a

simultaneous solution of the conservation of momentum and mass in the complex three-dimensional airway and tissue structure, which has yet to be performed in the respiratory tract. A finite difference solution of Fick's Law has been obtained in the TB and PU region by assuming no gas-phase component to mass transport, which eliminates the solution to the momentum equation (Miller et al., 1985). To include the gas-phase component, k_g , Hanna et al. (1989) and Lou (1993) used empirically determined k_g values in conjunction with conservation of mass in the liquid phase to solve for local absorption rates in a finite difference model.

Finite difference solutions are numerically intensive, however, and must be solved for each gas. Scaling of the transport coefficients based on the physicochemical properties of the gas thereby allows scaling of the absorption rate without labor intensive calculations. Furthermore, the transport coefficients may be determined empirically, reducing concern for the appropriateness of the modeling assumptions. Two-phase mass transport resistance models incorporating overall mass transport coefficients have been used in other applications, such as the evaluation of atmospheric absorption of gases by aerosols (Seinfeld, 1986), volatilization or absorption of gases by surface water bodies (Lyman et al., 1990), operation of air strippers (Perry and Chilton, 1973), and absorption in the respiratory tract (Miller et al., 1985; Hanna et al., 1989).

To simplify the respiratory tract into a two-phase resistance model for illustration of the overall mass transport approach, it must be assumed that the blood concentration is constant. For very reactive gases, such as ozone, it can further be assumed to be zero. Under these conditions, the transport of the gas would occur primarily through the air phase and surface-liquid/tissue phase. It is assumed that the surface-liquid and tissue phases are a single phase because of the limited data to identify differing transport parameters for these two phases. The two-phase transport is shown in Figure I-2. The overall transport or flux, N , through these two phases is expressed by

$$N = K_g(C_g - C_{1/g}) \quad (I-1)$$

where C_g is the bulk gas phase (or air phase) concentration, and $C_{1/g}$ is the gas phase concentration in equilibrium with the bulk surface-liquid/tissue phase concentration, C_1

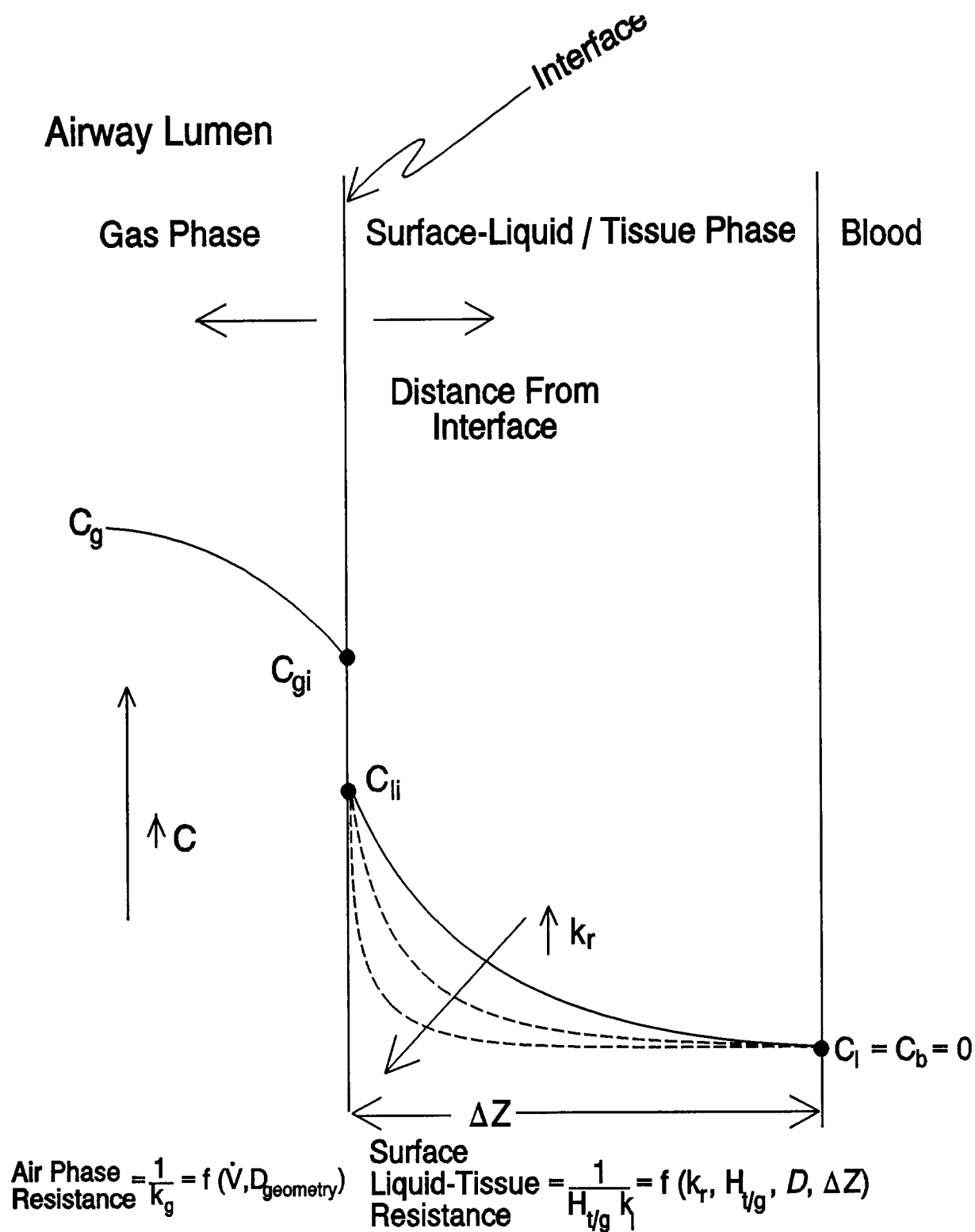

Figure I-2. Schematic of two-phase mass transport resistance model. The definitions for the parameter symbols are provided in Table I-1.

(Perry and Chilton, 1973), such that $C_{l/g}$ is equal to the ratio of the surface-liquid/tissue concentration, C_l , to the gas partition coefficient, $H_{l/g}$.

The overall mass transport coefficient may be determined from the transport coefficients of each individual phase. It is obtained by considering the flux through each phase (Perry and Chilton, 1973) such that

$$N_g = k_g(C_g - C_{gi}) \quad (I-2)$$

where N_g is the flux through the air phase, k_g is the transport coefficient in the gas phase, and C_{gi} is the gas-phase concentration at the interface of the gas phase and the surface-liquid tissue phase, and

$$N_l = k_l(C_{li} - C_l) \quad (I-3)$$

where N_l is the flux through the surface liquid-tissue phase, k_l is the transport coefficient in the surface-liquid/tissue phase, and C_{li} is the surface-liquid/tissue concentration at the interface of the gas phase and the surface-liquid/tissue phase.

Steady state (or quasi-steady state as occurs in the respiratory tract during inhalation or exhalation) requires the following condition:

$$N = N_g = N_l, \quad (I-4)$$

or

$$N = K_g(C_g - C_{l/g}) = k_g(C_g - C_{gi}) = k_l(C_{li} - C_l). \quad (I-5)$$

In the two-phase resistance approach defined by Equation I-5 above, the overall mass transport resistance is defined by the reciprocal of the mass transport coefficient, $1/K_g$, and is composed of the resistance to lateral movement of the absorbing gas through the air and

through the liquid and tissue as shown in Figure I-2. The resistance in series can be derived from Equation I-5 as

$$\frac{1}{K_g} = \frac{1}{k_g} + \frac{1}{H_{t/g}k_l}. \quad (\text{I-6})$$

In the case where the surface liquid and tissue cannot be assumed to be a single compartment, a separate partition coefficient and transport coefficient would need to be incorporated into Equation I-6.

The definition of the overall mass transport coefficient provided in Equation I-6 may be used to evaluate the conditions in which a single phase, either gas phase or surface-liquid/tissue phase, determines the overall mass transport coefficient. To demonstrate predominance of a single phase, it is further assumed that blood flow does not contribute to the overall mass transport coefficient (i.e., that there is no accumulation in blood). In the case of a reactive gas and/or a gas relatively soluble in both the tissue and blood, the transport resistance through the gas phase, $1/k_g$, may be greater than the transport resistance in the other phases (i.e., $k_g \ll H_{t/g}k_l$) such that

$$1/K_g \approx 1/k_g. \quad (\text{I-7})$$

The gas phase term, k_g , is dependent on flow rate, flow geometry, and the gas phase diffusivity. In cross-species comparisons, the flow geometry differences of the species are likely to predominately determine k_g . Additionally, recent data found that k_g differed significantly between living subject geometry and cadaver geometry so that it is reasonable to expect geometry to affect interspecies differences (Lou, 1993).

Liquid phase controlled absorption (i.e., $H_{t/g}k_l \ll k_g$) is typically identified by a gas of moderate to low water solubility and low reactivity. In the case of a nonreactive gas, $H_{t/g}k_l$ may be approximated by the surface-liquid/tissue:gas partition coefficient, the liquid diffusivity (D_l), and the thickness of the liquid-tissue layer (Δy), such that

$$H_{t/g}k_1 \approx \frac{D_1}{\Delta y}H_{t/g}. \quad (I-8)$$

For reactive gases, k_1 would need to be evaluated to include the transformation rate (Bird et al., 1960; Perry and Chilton, 1973; Ultman, 1988). However, as the reactivity increases, it is less likely that the absorption rate will remain liquid phase controlled due to the increasing influence of the gas phase. In the case of a liquid-controlled absorption process, $H_{t/g}k_1$ may be substituted for k_g in Equation I-7.

As discussed, each of the transport coefficients is dependent on the transport properties of the gas within the respective phase that alter the concentration gradient indicated in Figure I-1. Thus, in the case of the gas phase mass transport coefficient, k_g , the mass transport is affected by the flow rate (ventilation rate), the gas phase diffusivity, and the local (regional) airway geometry. The dependence of k_g on these parameters is discussed in greater detail by Hanna et al. (1989) and Lou (1993). The surface-liquid/tissue phase transport coefficient is determined by the phase thickness (Δz), the liquid phase diffusivity, and the reactivity (e.g., ionic dissociation and metabolism) in the surface-liquid/tissue. The dependence of k_1 on these parameters is discussed in greater detail by Ultman (1988).

The penetration fraction model may be used to empirically determine the overall mass transport coefficient (Section I.2.1), provided the fractional penetration, fp , is measured. Because fp is both gas and species specific, the K_g value will similarly be gas and species specific. However, data for fp and K_g specific to a gas or gases may be used in a predictive fashion by scaling to the physicochemical properties of solubility, diffusivity, and reactivity.

Using values of K_g obtained in a single species, K_g can be scaled within the species for a different gas by decomposing K_g to the individual transport resistances (i.e., the gas phase and surface-liquid/tissue phase mass transport coefficient). In humans, empirical measures of k_g have been obtained in casts of the human nasal cavity (Nuckols, 1981; Hanna and Scherer, 1986; Lou, 1993) and can be used to decompose K_g . Although k_g is species specific, it may be scaled to other gases by scaling to the gas diffusivity (Hanna et al., 1989). Therefore, for a gas in which $k_g \ll H_{t/g}k_1$, this scaling may be sufficient to predict fp and dose. Similar scaling using the diffusivity and reactivity of a gas for which fp is unknown may be performed for the surface-liquid/tissue phase transport coefficient, k_1 . For gases in which the

prediction of K_g , and therefore f_p , depends on the surface-liquid/tissue phase, the solubility and reactivity of the gas must also be used in the scaling (Equation I-6).

A difficulty arises due to the lack of k_g values in airways of laboratory animals. Decomposition of an empirically determined K_g to the individual components must therefore be made based on a data base in which $H_{t/g}k_l$ may be determined. An approach is under development to obtain data from several gases to decompose K_g into each component and perform an evaluation of k_g for gases in each category to obtain a measure of consistency within a species. This effort is underway and will be published as a technical support document to this publication.

Absorption within the respiratory tract cannot always be assumed to be modeled by a two-phase transport resistance model ignoring the blood concentration. In cases where the absorption in the blood contributes to overall absorption, additional mass transport resistances must be considered. Accumulation in the bloodstream may reduce the concentration driving force (and thereby reduce the absorption rate) as well as contribute to the development of a back pressure, which may result in desorption during exhalation due to the reversal in the concentration gradient between the air and tissue. Gases that are likely to exhibit these characteristics are Category 2 gases that are water soluble and rapidly reversibly reactive or those that are moderately to slowly irreversibly metabolized in the respiratory tract, previously referred to as "transition gases" (Dahl, 1990). The contribution of the blood to both the overall mass transport resistance and to the potential for desorption during exhalation was considered in the categorization of gases based on their physicochemical properties. The categorization of gases with respiratory effects is used as the basis for defining the model structure and, in particular, the overall mass transport coefficient.

I.2 MODEL FOR CATEGORY 1 GASES

Category 1 gases are defined as gases that are highly water soluble and/or that may react rapidly and irreversibly in the surface liquid and tissue of the respiratory tract. Due to these physicochemical characteristics, these gases are distinguished by the property that a significant back pressure from the surface-liquid/tissue phase during exhalation does not develop. A back pressure resulting from the reversal in the concentration gradient between

the gas and the surface-liquid/tissue phase may cause significant desorption during exhalation which would require an adjustment to the dose as is considered in the model for Category 2 gases. Category 1 gases are further distinguished by the property that the gas does not significantly accumulate in the blood, which would reduce the concentration driving force and hence reduce the absorption rate. Examples of gases classified as Category 1 are hydrogen fluoride, chlorine, formaldehyde, and the volatile organic acids and esters.

In the following, the two empirical models discussed above are synthesized to allow the doses of gases of differing physicochemical properties to be scaled across species. The penetration fraction model will be utilized to determine the fraction absorbed in the ET region, the concentration entering and dose to the TB region, and the remaining concentration entering the PU region. The ventilation-perfusion model is used to evaluate dose to the PU region by substituting the concentration of the air exiting the TB region in place of the ambient concentration. The overall schematic for the approach is shown in Figure I-3. The definitions for the parameter symbols are provided in Table I-1.

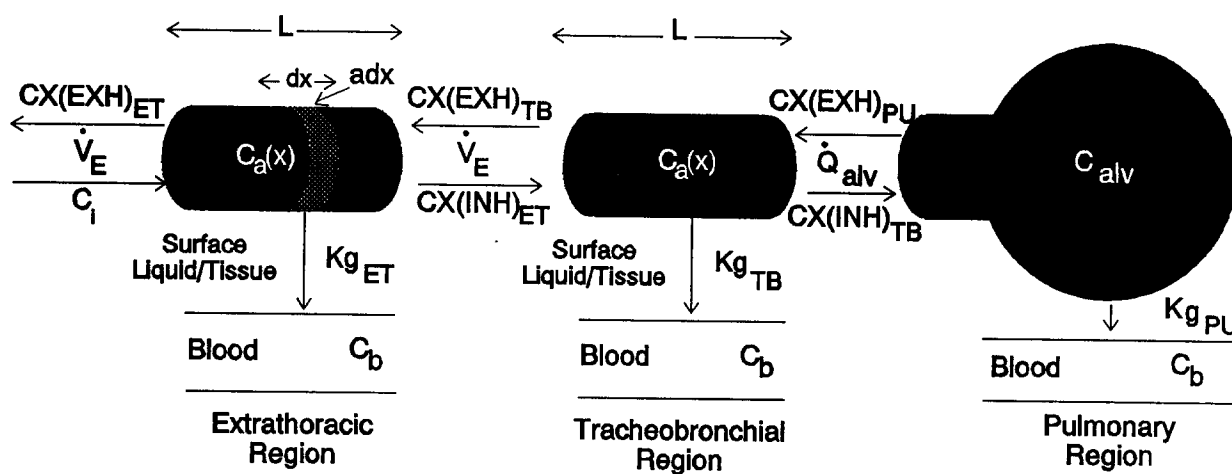

Figure I-3. Schematic of modeling approach to estimate regional respiratory tract dose of gases. The definitions for the parameter symbols are provided in Table I-1.

I.2.1 Extrathoracic Region: The Penetration Fraction Model

The penetration fraction model, designed to evaluate the upper airway scrubbing efficiency, is based on a mass-balance approach. The change in mass traversing the gas phase of the extrathoracic region is balanced by the mass absorbed at the gas-liquid interface of the airway. This balance is written as

$$\dot{V} \frac{dC_g}{dx} = -K_{gET} a(C_i - C_{b/g}) \quad (I-9)$$

where \dot{V} is the volumetric flow rate; dC_g/dx is the rate of change of the airstream concentration (gas phase) as a function of distance into the airway, x ; K_{gET} is the overall mass transport coefficient between the airstream and the blood in the ET region; a is the local airway perimeter; C_i is the inspired gas concentration; and $C_{b/g}$ is the gas concentration that would be in equilibrium with the blood concentration. $C_{b/g}$ is equal to the ratio of the blood concentration, C_b , to the blood:gas (air) partition coefficient, $H_{b/g}$.

To evaluate the change in concentration over the length of the ET region, Equation I-9 is integrated resulting in the following relationship:

$$\frac{(CX(INH)_{ET} - C_{b/g})}{(C_i - C_{b/g})} = e^{\left(\frac{-K_{gET} aL}{\dot{V}}\right)}, \quad (I-10)$$

where $CX(INH)_{ET}$ is the gas concentration exiting the ET region and L is the length of the airway such that the product of a and L is the surface area of the ET region, SA_{ET} .

Equation I-10 indicates that $CX(INH)_{ET}$ will equal C_i at an infinite volumetric flow rate.

In the case of Category 1 gases/vapors, $CX(INH)_{ET}$ and C_i are much greater than $C_{b/g}$, so that Equation I-10 can be further reduced to

$$f_{PET} = \frac{CX(INH)_{ET}}{C_i} = e^{\left(\frac{-K_{gET} SA_{ET}}{\dot{V}}\right)} \quad (I-11)$$

where fp_{ET} is the penetration fraction through the ET region and is given as the ratio of the gas concentration exiting the region, $CX(INH)_{ET}$, to the gas concentration entering the airway, C_i . The relationship shown in Equation I-11 suggests that the product of the overall mass transport coefficient and the surface area may be obtained by plotting fp_{ET} as a function of volumetric flow rate. Indeed, many investigators have used this method to present empirical results (Aharonson et al., 1974; Kleinman, 1984; Morris and Blanchard, 1992). As an example, provided that SA_{ET} is known, Equation I-11 may be used to evaluate K_{gET} , in the form of

$$\ln fp_{ET} = - K_{gET} SA_{ET} \left[\frac{1}{\dot{V}} \right], \quad (I-12)$$

where $K_{gET} SA_{ET}$ is the slope if the relationship between $\ln fp_{ET}$ and $1/\dot{V}$ is linear.

Equation I-12 is similar to the relationship developed by Morris and Blanchard (1992). Morris and Blanchard chose to fit D/fp_{ET} to $1/\dot{V}$, where D is the deposited fraction, $1-fp_{ET}$. Using Equation I-12 in conjunction with a power series expansion of the exponential term of Equation I-11 results in

$$\frac{D}{fp_{ET}} = \frac{K_{gET} SA_{ET}}{\dot{V}}. \quad (I-13)$$

It should be noted, however, that plotting either $\ln fp_{ET}$ or D/fp_{ET} against $1/\dot{V}$ may not be linear. The nonlinearity was first reported by Aharonson et al. (1974). Both Ultman (1988) and Hanna et al. (1989) attribute the nonlinearity to the contribution of the gas phase mass transport coefficient, k_g , to the overall transport rate. Thus, K_g is a function of \dot{V} when affected by k_g , thereby producing the nonlinearity.

Equation I-6 may be used to evaluate K_{gET} if sufficient information is available to calculate the individual mass transport coefficient for each phase. Empirical determinations of K_{gET} may also be obtained from Equation I-12. Furthermore, in the case of gas phase controlled absorption (i.e., in the case of Category 1 gases) where $K_{gET} \approx k_{gET}$, Equation I-12 can be used to evaluate the gas phase mass transport coefficient (k_g) for each species.

To evaluate k_g for a single species, empirical measures of the fractional penetration of a gas in which the gas phase contributes to (or controls) the overall mass transport resistance must have been determined empirically. The fractional penetration obtained at several flow rates may be used to evaluate k_g from the following relationship, which is obtained by combining Equations I-12 and I-6 such that

$$-\ln fp_{ET} = \left(\frac{\dot{V}}{SA_{ET}} \right) \left(\frac{1}{k_g} + \frac{1}{H_{t/g}k_1} \right). \quad (I-14)$$

The value of k_g and its functional dependence on \dot{V} is determined by curve fitting the empirically determined fp_{ET} and \dot{V} , provided that $H_{t/g}$ and k_1 are known. In the case of a nonreactive gas, k_1 may be simply estimated. Methods are also available to estimate k_1 for reactive gases (Ultman, 1988). It should be noted that k_g will differ among gases and that k_g is a function of ventilation rate. Therefore, k_g must be scaled by the gas phase diffusivity. The ventilation dependence of k_g allows the two terms, gas phase and surface-liquid/tissue phase, to be separated. Thus, k_g may be evaluated from data of fp_{ET} of several gases to obtain a reasonable estimate of k_g in a single species, particularly for the rat, for which empirical data are most available. Values of k_g in other species may also be obtained from published uptake data (Morris and Smith, 1982; Stott and McKenna, 1984; Morris et al., 1986, 1991; Morris and Cavanagh, 1987; Morris, 1990; Dahl et al., 1991b; Bogdanffy et al., 1991; Morris and Blanchard, 1992; Bogdanffy and Taylor, 1993; Kuykendall et al., 1993).

By using the heat and mass transfer analogy, measures of change in inspired temperature may be used to obtain an independent estimate of k_g (Hanna et al., 1989). The mass transport coefficient, k_g , has also already been determined in human casts based on both mass transport studies (Hanna et al., 1989; Lou, 1993) and heat transport studies (Nuckols, 1981) from which k_g is directly calculated.

If the absorption is gas phase controlled (i.e., absorption is completely determined by transport through the gas phase), Equation I-12 may be used to determine the gas phase mass transport coefficient for a single species such that

$$k_g \approx \frac{-\dot{V} \ln fp_{ET}}{SA_{ET}}, \quad (I-15)$$

where k_g is substituted for K_g . Because k_g is a function of flow rate, a plot of $\ln fp_{ET}$ against $1/\dot{V}$ will be nonlinear. The nonlinearity determined from empirical data of a gas phase controlled absorption process can be used to evaluate the flow rate dependence of k_g . The flow rate dependence is of the form \dot{V}^n where n is typically between 0.5 to 0.8 (Hanna et al., 1989). Note also that k_g can not be determined if there is no penetration (i.e., $fp_{ET} = 0$) because $\ln fp_{ET}$ is undefined. The value of k_g at a specific flow rate and in a single species should be relatively constant, changing only slightly as a function of the gas diffusivity. Using values for k_g determined in humans and in a laboratory animal species allows the scaling for dose in gas phase controlled absorption (i.e., where $k_g \ll H_{t/g}k_l$).

In the case of surface-liquid/tissue phase controlled absorption, where $K_g \approx H_{t/g}k_l$, the value will be chemical-specific due to the dependence of $H_{t/g}k_l$ on solubility and reactivity. Under these circumstances, $H_{t/g}k_l$ would replace k_g in Equation I-14. The regression of $\ln fp_x$ to $1/\dot{V}$ would be linear provided that the reactivity is not saturable. Michaelis-Menton kinetics can be used to define k_l and incorporate saturation kinetics which may introduce a nonlinearity. However, saturation kinetics may be better described by the model for Category 2 gases in which there may be a significant accumulation in blood thereby reducing the absorption concentration gradient during inhalation, as well as a potential reversal of the concentration gradient, which would result in desorption during exhalation.

The rate of mass absorbed at the gas-surface interface of the airway in a region is simply the product of the absorbed fraction, $1-fp_{ET}$, and the total mass inhaled during a single breath, $\dot{V}C_i$. With this knowledge, a suitable metric of dose must now be chosen. If dose were to be defined on a mass per volume basis, it would implicitly assume that the outcome would be determined by concentration (i.e., mass/volume). This assumption would therefore argue that the most appropriate definition of dose should be one defined on the basis of surface area (i.e., the mass flux, or dose, defined as mass per surface area-time). The mass flux implies a concentration gradient in the tissue such that the localized concentration would be highest at the surface. The mass flux is thereby a more accurate predictor of the peak localized concentration and will be used to define dose for this application. The

regional gas dose (RGD), defined as the mass absorbed per surface area per minute ($\text{mg}/\text{cm}^2\text{-min}$), to the extrathoracic region (ET) is given by

$$\text{RGD}_{\text{ET}} (\text{mass} / \text{cm}^2 - \text{min}) = (1 - f_{\text{pET}}) \frac{C_i \dot{V}}{\text{SA}_{\text{ET}}}. \quad (\text{I-16})$$

From Equation I-11, the regional gas dose to the ET may also be expressed as

$$\text{RGD}_{\text{ET}} = \frac{C_i \dot{V}}{\text{SA}_{\text{ET}}} \left(1 - e^{-\frac{K_{\text{bET}} \text{SA}_{\text{ET}}}{\dot{V}_E}} \right). \quad (\text{I-17})$$

The dose expressed in Equation I-17 is applicable to any animal species provided the appropriate parameters of that species are used in the assessment. For example, because the purpose of this appendix is to address extrapolation of respiratory effects from experimental animal species to humans, the minute volume (\dot{V}_E) is used as the default volumetric flow rate in the remainder of the derivations because it approximates the flow rate at which the animal was breathing during the experimental exposure. Further justification of the use of minute volume is the relatively little desorption that occurs during exhalation, a requirement by definition of Category 1 gases, suggesting that the dose should be averaged over the entire cycle. The default values for surface area and minute volume for the various species are provided in Chapter 4.

The regional gas dose ratio for the extrathoracic region (RGDR_{ET}) of differing species used to calculate NOAEL(HEC) can also be developed using Equation I-17. A comparison between humans and an experimental test species would result in the following regional gas dose ratio (RDGR):

$$\text{RGDR}_{\text{ET}} = \frac{(\text{RGD}_{\text{ET}})_A}{(\text{RGD}_{\text{ET}})_H} = \frac{\left(\frac{C_i \dot{V}_E}{\text{SA}_{\text{ET}}} \right)_A \left(1 - e^{-\frac{K_{\text{bET}} \text{SA}_{\text{ET}}}{\dot{V}_E}} \right)_A}{\left(\frac{C_i \dot{V}_E}{\text{SA}_{\text{ET}}} \right)_H \left(1 - e^{-\frac{K_{\text{bET}} \text{SA}_{\text{ET}}}{\dot{V}_E}} \right)_H}, \quad (\text{I-18})$$

where the subscript A and H refer to values for laboratory animals and humans respectively. Because it is assumed that the laboratory animals and humans are exposed to the same concentration for purposes of extrapolating the observed toxicity, C_i can be deleted.

Equation I-18 represents the most general form of the ratio of ET regional dose between laboratory test species and humans for Category 1 gases. This equation will therefore serve as the basis for the default dosimetric adjustment. To evaluate the ratio, each term will need to be determined for the species of interest.

By definition, gases in Category 1 would be associated with large K_g values due to high k_g and low $H_{t/g}k_1$ terms (Ultman, 1988). Thus, in these cases the exponent is greater than or equal to 1. Under these circumstances, the exponential term (the penetration fraction) approaches zero (less than 5% error when $K_{gET} SA_{ET}/\dot{V}_{ET}$ is 3) and the $RGDR_{ET}$ is simply¹

$$RGDR_{ET} = \frac{(RGD_{ET})_A}{(RGD_{ET})_H} \approx \frac{\left(\frac{\dot{V}_E}{SA_{ET}}\right)_A}{\left(\frac{\dot{V}_E}{SA_{ET}}\right)_H}. \quad (I-19)$$

$RGDR_{ET}$ is determined by the ratio of ventilation rates and surface areas in each species. Assuming that the penetration fraction (i.e., the exponential term) reduces to zero is equivalent to assuming the gas is absorbed entirely in the ET region. Furthermore, based on Equation I-16, the absorption is assumed to be distributed equally. Studies currently in progress are anticipated to provide more localized measures of dose to the nasal cavity (Kimbell et al., 1993; Lou, 1993).

¹Note that Equation I-19 may also be derived from Equation I-18 by determining the conditions whereby

$$\frac{(1 - \exp^{-K_{gET} \frac{SA_{ET}}{\dot{V}_E}})_A}{(1 - \exp^{-K_{gET} \frac{SA_{ET}}{\dot{V}_E}})_H} \approx 1.$$

These conditions will be a function of the default values for respiratory tract surface area and minute volume as well as the absolute value of the overall mass transport coefficient.

I.2.2 Tracheobronchial Region: The Fractional Penetration Model

The penetration fraction model, and the analysis discussed in the previous section on the ET region, may also be used to describe absorption in the TB region. The major difference is that the concentration at the inlet of the TB region will be dependent on absorption in the ET region. Therefore, the penetration fraction through the TB region, fp_{TB} , may be described using Equation I-11 such that

$$fp_{TB} = \frac{CX(INH)_{TB}}{CX(INH)_{ET}} = e^{-\frac{K_{gTB} SA_{TB}}{\dot{V}_E}}, \quad (I-20)$$

where $CX(INH)_{TB}$ is the concentration exiting the TB region; $CX(INH)_{ET}$ is the concentration exiting the ET region and subsequently entering the TB region; SA_{TB} is the TB surface area; \dot{V}_E is the species-specific minute volume used in place of the volumetric flow rate, due to averaging between inhalation and exhalation; and K_{gTB} is the overall mass transport coefficient in the TB region. In the TB region, K_{gTB} and \dot{V}_E can be defined for each specific bronchial generation or as a value for the entire region as a whole using the trachea to characterize both parameters (Nuckols, 1981). Because measures of K_{gTB} are only available regionally, the value for K_{gTB} as used in the remaining discussion should be assumed to refer to a regional determination.

The regional gas dose to the TB region, RGD_{TB} , may be defined similar to the ET dose (Equation I-17) such that

$$RGD_{TB} = \frac{CX(INH)_{ET} \dot{V}_E}{SA_{TB}} \left(1 - e^{-\frac{K_{gTB} SA_{TB}}{\dot{V}_E}} \right). \quad (I-21)$$

The dose ratio for the TB region ($RGDR_{TB}$) between an experimental animal species and humans is therefore

$$\text{RGDR}_{\text{TB}} = \frac{(\text{RGD}_{\text{TB}})_{\text{A}}}{(\text{RGD}_{\text{TB}})_{\text{H}}} = \frac{\left[\frac{\text{CX}(\text{INH})_{\text{ET}} \dot{V}_{\text{E}}}{\text{SA}_{\text{TB}}} \right]_{\text{A}}}{\left[\frac{\text{CX}(\text{INH})_{\text{ET}} \dot{V}_{\text{E}}}{\text{SA}_{\text{TB}}} \right]_{\text{H}}} \frac{\left(1 - e^{-\frac{-K_{\text{ETB}} \text{SA}_{\text{TB}}}{\dot{V}_{\text{E}}}} \right)_{\text{A}}}{\left(1 - e^{-\frac{-K_{\text{ETB}} \text{SA}_{\text{TB}}}{\dot{V}_{\text{E}}}} \right)_{\text{H}}}, \quad (\text{I-22})$$

where A and H refer to laboratory animals and humans, respectively. Assuming the same inhaled concentration, the above dose ratio will be divided by C_i/C_i resulting in the concentration ratio $(\text{CX}(\text{INH})_{\text{ET}}/C_i)$ in the numerator and denominator for both laboratory animal and human. This concentration ratio is fp_{ET} . The resultant gas dose ratio to the TB region is thereby

$$\text{RGDR}_{\text{TB}} = \frac{(\text{RGD}_{\text{TB}})_{\text{A}}}{(\text{RGD}_{\text{TB}})_{\text{H}}} = \frac{\left[\frac{\dot{V}_{\text{E}}}{\text{SA}_{\text{TB}}} \right]_{\text{A}}}{\left[\frac{\dot{V}_{\text{E}}}{\text{SA}_{\text{TB}}} \right]_{\text{H}}} \frac{(fp_{\text{ET}})_{\text{A}}}{(fp_{\text{ET}})_{\text{H}}} \frac{\left(1 - e^{-\frac{-K_{\text{ETB}} \text{SA}_{\text{TB}}}{\dot{V}_{\text{E}}}} \right)_{\text{A}}}{\left(1 - e^{-\frac{-K_{\text{ETB}} \text{SA}_{\text{TB}}}{\dot{V}_{\text{E}}}} \right)_{\text{H}}}. \quad (\text{I-23})$$

Thus, the results obtained from an evaluation of ET penetration are used to determine the dose to the TB region.

Similar to the ET region, Equation I-23 may be simplified when K_g is large (less than 5% error if $K_{\text{ETB}} \text{SA}_{\text{TB}}/\dot{V}_{\text{ETB}}$ is greater than or equal to 3) such that Equation I-23 becomes²

²Note that Equation I-24 may also be derived from Equation I-23 by determining the conditions whereby

$$\frac{\left(1 - \exp^{-\frac{-K_{\text{ETB}} \text{SA}_{\text{TB}}}{\dot{V}_{\text{E}}}} \right)_{\text{A}}}{\left(1 - \exp^{-\frac{-K_{\text{ETB}} \text{SA}_{\text{TB}}}{\dot{V}_{\text{E}}}} \right)_{\text{H}}} \approx 1.$$

These conditions will be a function of the default values for respiratory tract surface area and minute volume as well as the absolute value of the overall mass transport coefficient.

$$\text{RGDR}_{\text{TB}} = \frac{(\text{RGD}_{\text{TB}})_A}{(\text{RGD}_{\text{TB}})_H} = \frac{\left[\frac{\dot{V}_E}{\text{SA}_{\text{TB}}} \right]_A}{\left[\frac{\dot{V}_E}{\text{SA}_{\text{TB}}} \right]_H} \frac{(\text{fp}_{\text{ET}})_A}{(\text{fp}_{\text{ET}})_H}. \quad (\text{I-24})$$

I.2.3 Pulmonary Region: The Bohr Model

Ultman (1988) proposed a gas absorption model for the PU region by coupling the Bohr model to predict expired air concentration with a model descriptive of the progressive increase in the capillary blood concentration of the PU circulation. The steady-state model was developed by a mass balance approach in which the rate of uptake in a capillary segment, dy , is balanced by the differential increase in the total blood concentration, which includes both the reacted (transformed) and the unreacted form of the absorbing gas. The PU absorption model is given by

$$K_{g\text{PU}} \text{SA}_{\text{PU}} (C_{\text{alv}} - C_{\text{b/g}}) dy/L = \dot{Q}_T (dC_{\text{b}} + dC_{\text{b/r}}), \quad (\text{I-25})$$

where, $K_{g\text{PU}}$ is the overall PU transport coefficient from the gas phase to the blood; SA_{PU} is the PU surface area; C_{alv} is the PU region gas concentration; $C_{\text{b/g}}$ is the blood gas tension in equilibrium with the blood concentration, C_{b} ; \dot{Q}_T is the cardiac output; and $C_{\text{b/r}}$ is the concentration of the gas in its chemically transformed state.

In the PU region, it is assumed that the absorption of the gas is not limited by absorption in the bloodstream. Therefore, perfusion-limited absorption processes are not considered in this appendix. As discussed earlier, perfusion-limited processes are more appropriate for PBPK models such as described in Appendix J.

Equation I-25 can be integrated such that

$$K_{g\text{PU}} \text{SA}_{\text{PU}} (C_{\text{alv}} - C_{\text{b/g}}) = \dot{Q}_T (C_{\text{T/V}} - C_{\text{T/A}}) \quad (\text{I-26})$$

where $C_{T/V}$ and $C_{T/A}$ are the concentration of the reacted and unreacted form of the absorbing gas in the venous (oxygenated) and arterial (unoxygenated—entering the PU region) blood, respectively. Consistent with the assumption that the blood concentration approaches zero (i.e., eliminating perfusion-limited absorption), $C_{T/A}$ is assumed to be much greater than $C_{T/V}$. Under these circumstances, the right-hand side of Equation I-26 is simply $(-\dot{Q}_T C_{T/A})$.

The overall mass transport coefficient in the PU region, $K_{g_{PU}}$, has been determined for carbon monoxide (CO) to be of the form (Ultman, 1988)

$$\frac{1}{K_{g_{PU}} SA_{PU}} = \frac{1}{k_m SA_{PU}} + \frac{1}{H_{t/g} k_r V_b}, \quad (I-27)$$

where k_m is the alveolar membrane diffusion coefficient and $k_m SA_{PU}$ is the alveolar membrane diffusing capacity, k_r is the reaction rate constant in blood, and V_b is the capillary blood volume. In the case of CO, the diffusion resistance ($1/k_m SA_{PU}$) is three times greater than the blood reaction term and the mass transport in the PU region is therefore limited by the diffusion resistance. The PU diffusion capacity of CO may thereby serve as a reasonable estimate of the diffusion resistance of a nonreactive gas. In the case of a gas reactive in the PU tissue, $K_{g_{PU}}$ may be approximated by:

$$\frac{1}{K_{g_{PU}} SA_{PU}} = \frac{1}{Ha (k_m SA_{PU})_{CO}} + \frac{1}{H_{t/g} k_r V_b} \quad (I-28)$$

where Ha is the Hatta number, a dimensionless parameter that depends on the ratio of the reaction to diffusion times. When the reaction is zero, the Hatta number is one and increases as the rate constant increases (Ultman, 1988). An increase in the Hatta number thus reduces the diffusion resistance and may increase the absorption rate.

The absorption rate to the bloodstream is also balanced by the change in airstream concentration. Using the Bohr model (Figure I-4), the mass balance of Equation I-26 is further expressed by:

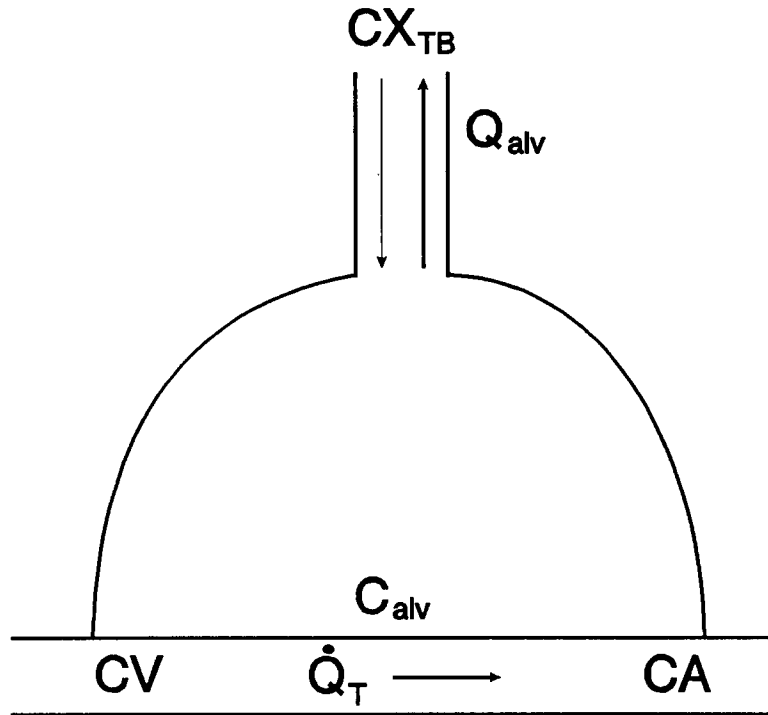

Figure I-4. Bohr model of ventilation and uptake. The definitions for the parameter symbols are provided in Table I-1.

$$\dot{Q}_{\text{alv}} (CX(\text{EXH})_{\text{TB}} - C_{\text{alv}}) = K_{\text{gPU}} SA_{\text{PU}} (C_{\text{alv}} - C_{\text{b/g}}) = -\dot{Q}_{\text{T}} C_{\text{T/A}}, \quad (\text{I-29})$$

where \dot{Q}_{alv} is the alveolar ventilation rate.

The first two terms in Equation I-29 are used to develop the ratio of the expired concentration to inspired concentration, which will be used as a penetration fraction of the PU region, f_{pPU} , defined as the ratio of C_{alv} to $CX(\text{INH})_{\text{TB}}$ such that

$$\frac{C_{\text{alv}}}{CX(\text{INH})_{\text{TB}}} = \frac{\dot{Q}_{\text{alv}}}{K_{\text{gPU}} SA_{\text{PU}} (1 - C_{\text{b/g}} / C_{\text{alv}}) + \dot{Q}_{\text{alv}}}. \quad (\text{I-30})$$

However, for the case of diffusion-limited absorption, $C_{\text{b/g}}$ is much less than C_{alv} such that the denominator on the right hand side of the Equation I-30 is simply $(K_{\text{gPU}} SA_{\text{PU}} + \dot{Q}_{\text{alv}})$.

The regional gas dose (RGD) to the pulmonary region (PU) is

$$\text{RGD}_{\text{PU}} = (1 - f_{\text{pPU}}) \frac{\dot{Q}_{\text{alv}}}{\text{SA}_{\text{PU}}} \text{CX}(\text{INH})_{\text{TB}}. \quad (\text{I-31})$$

Combining Equation I-30 and I-31 results in the following relationship:

$$\text{RGD}_{\text{PU}} = \left(1 - \frac{\dot{Q}_{\text{alv}}}{K_{\text{gPU}} \text{SA}_{\text{PU}} + \dot{Q}_{\text{alv}}}\right) \frac{\dot{Q}_{\text{alv}}}{\text{SA}_{\text{PU}}} \text{CX}(\text{INH})_{\text{TB}}, \quad (\text{I-32})$$

where the regional gas dose ratio to the pulmonary region (RGDR_{PU}) between laboratory animal and humans is given by

$$\text{RGDR}_{\text{PU}} = \frac{(\text{RGD}_{\text{PU}})_{\text{A}}}{(\text{RGD}_{\text{PU}})_{\text{H}}} = \frac{\left(1 - \frac{\dot{Q}_{\text{alv}}}{K_{\text{gPU}} \text{SA}_{\text{PU}} + \dot{Q}_{\text{alv}}}\right)_{\text{A}}}{\left(1 - \frac{\dot{Q}_{\text{alv}}}{K_{\text{gPU}} \text{SA}_{\text{PU}} + \dot{Q}_{\text{alv}}}\right)_{\text{H}}} \frac{(\dot{Q}_{\text{alv}}/\text{SA}_{\text{PU}})_{\text{A}}}{(\dot{Q}_{\text{alv}}/\text{SA}_{\text{PU}})_{\text{H}}} \frac{(\text{CX}(\text{INH})_{\text{TB}})_{\text{A}}}{(\text{CX}(\text{INH})_{\text{TB}})_{\text{H}}}. \quad (\text{I-33})$$

Dividing both numerator and denominator by the inspired air concentration converts the last term to the product of the penetration fractions of the preceding regions such that

$$\text{RGDR}_{\text{PU}} = \frac{(\text{RGD}_{\text{PU}})_{\text{A}}}{(\text{RGD}_{\text{PU}})_{\text{H}}} = \frac{\left(1 - \frac{\dot{Q}_{\text{alv}}}{K_{\text{gPU}} \text{SA}_{\text{PU}} + \dot{Q}_{\text{alv}}}\right)_{\text{A}}}{\left(1 - \frac{\dot{Q}_{\text{alv}}}{K_{\text{gPU}} \text{SA}_{\text{PU}} + \dot{Q}_{\text{alv}}}\right)_{\text{H}}} \frac{(\dot{Q}_{\text{alv}}/\text{SA})_{\text{A}}}{(\dot{Q}_{\text{alv}}/\text{SA})_{\text{H}}} \frac{(f_{\text{pTB}})_{\text{A}}}{(f_{\text{pPU}})_{\text{H}}} \frac{(f_{\text{pET}})_{\text{A}}}{(f_{\text{pET}})_{\text{H}}}, \quad (\text{I-34})$$

where the ratios $(f_{\text{pTB}})_{\text{A}}/(f_{\text{pTB}})_{\text{H}}$ and $(f_{\text{pET}})_{\text{A}}/(f_{\text{pET}})_{\text{H}}$ must be determined from the penetration fraction model for the TB and ET regions, respectively. Equation I-34 may be further reduced to

$$\text{RGDR}_{\text{PU}} = \frac{(\text{RGD}_{\text{PU}})_{\text{A}}}{(\text{RGD}_{\text{PU}})_{\text{H}}} = \frac{\left(\frac{K_{\text{gPU}} \text{SA}_{\text{PU}}}{K_{\text{gPU}} \text{SA}_{\text{PU}} + \dot{Q}_{\text{alv}}}\right)_{\text{A}} \left(\frac{\dot{Q}_{\text{alv}}}{\text{SA}_{\text{PU}}}\right)_{\text{A}} (f_{\text{PTB}})_{\text{A}} (f_{\text{PET}})_{\text{A}}}{\left(\frac{K_{\text{gPU}} \text{SA}_{\text{PU}}}{K_{\text{gPU}} \text{SA}_{\text{PU}} + \dot{Q}_{\text{alv}}}\right)_{\text{H}} \left(\frac{\dot{Q}_{\text{alv}}}{\text{SA}_{\text{PU}}}\right)_{\text{H}} (f_{\text{PTB}})_{\text{H}} (f_{\text{PET}})_{\text{H}}}, \quad (\text{I-35})$$

from which the limiting values for the dose ratio may be obtained. At large values of K_{gPU} , as would be the case for Category 1 gases, Equation I-35 reduces to:

$$\text{RGDR}_{\text{PU}} = \frac{(\text{RGD}_{\text{PU}})_{\text{A}}}{(\text{RGD}_{\text{PU}})_{\text{H}}} = \frac{\left(\frac{\dot{Q}_{\text{alv}}}{\text{SA}_{\text{PU}}}\right)_{\text{A}} (f_{\text{PTB}})_{\text{A}} (f_{\text{PET}})_{\text{A}}}{\left(\frac{\dot{Q}_{\text{alv}}}{\text{SA}_{\text{PU}}}\right)_{\text{H}} (f_{\text{PTB}})_{\text{H}} (f_{\text{PET}})_{\text{H}}}. \quad (\text{I-36})$$

I.2.4 DEFAULT APPROACH FOR CATEGORY 1 GASES

As mentioned earlier, more elaborate models such as those using a finite difference solution to the convective-diffusive equation have been developed and applied to specific gases for evaluation of local absorption rates (McJilton et al., 1972; Miller et al., 1985). The method in this appendix presents a reasonable alternative based on fewer parameters and one that is amenable to the types of uptake data routinely generated in some laboratories (Morris and Smith, 1982; Stott and McKenna, 1984; Morris and Cavanagh, 1986, 1987; Morris, 1990; Morris et al., 1986, 1991; Dahl et al., 1991b; Morris and Blanchard, 1992; Bogdanffy et al., 1991; Bogdanffy and Taylor, 1993; Kuykendall et al., 1993). It is hoped that this approach encourages development of these types of data for the various toxic air pollutants that the inhalation reference concentration RfC methods are intended to address.

Because uptake data on which to base K_{g} values are not available for many toxic chemicals, this section presents default approaches to those presented in the preceding Section I.2. The default approaches have been derived based on analyses of the limiting conditions described in that section. It is assumed that the values for \dot{V}_{E} and the SA values for the various respiratory tract regions will be constants within each species.

I.2.4.1 Default Approach for Extrathoracic Region

By definition, Category 1 gases are associated with large K_g values, which simplifies the regional gas dose ratio in the extrathoracic region ($RGDR_{ET}$) to

$$RGDR_{ET} = \frac{(RGD_{ET})_A}{(RGD_{ET})_H} \approx \frac{\left(\frac{\dot{V}_E}{SA_{ET}}\right)_A}{\left(\frac{\dot{V}_E}{SA_{ET}}\right)_H}. \quad (I-37)$$

The ratio is based on an averaged dose over the entire ET region because more localized dosimetry is not yet possible across all species. This default is appropriate when K_{gET} (SA_{ET}/\dot{V}_E) is greater than 3 or when

$$\frac{(1 - \exp^{-K_{gET} \frac{SA_{ET}}{\dot{V}_E}})_A}{(1 - \exp^{-K_{gET} \frac{SA_{ET}}{\dot{V}_E}})_H} \approx 1.$$

The objective of the dosimetric adjustment is to address interspecies extrapolation of gas doses associated with toxic respiratory effects. Because it has been established (Dahl, 1990; ICRP, 1993) that the types of compounds that are likely to cause respiratory tract toxicity have high reactivity (either ionic dissociation or metabolism) and solubility (i.e., have relatively high K_{gET}), Equation I-37 is thus chosen as the default approach for dosimetric adjustment of gases with ET effects. The regional gas dose ratio ($RGDR_{ET}$) calculated in Equation I-37 would be used as the DAF_r or the multiplier of the $NOAEL^*(ADJ)$ as described in Chapter 4 (Equation 4-3).

I.2.4.2 Default Approach for Tracheobronchial Region

As discussed above, the basis of the methods for Category 1 gases was the penetration fraction model to determine the fraction of inhaled dose penetrating the ET region and

thereby available for uptake in the TB region. Thus, the regional gas dose ratio for the tracheobronchial region ($RGDR_{TB}$) is calculated as

$$RGDR_{TB} = \frac{(RGD_{TB})_A}{(RGD_{TB})_H} = \frac{\left(\frac{\dot{V}_E}{SA_{TB}}\right)_A}{\left(\frac{\dot{V}_E}{SA_{TB}}\right)_H} \frac{(fp_{ET})_A}{(fp_{ET})_H} \frac{(1 - e^{-\frac{K_{gTB} SA_{TB}}{\dot{V}_E}})_A}{(1 - e^{-\frac{K_{gTB} SA_{TB}}{\dot{V}_E}})_H} \quad (I-38)$$

If the penetration fraction is unknown due to the lack of data on K_{gTB} , it is reasonable to assume that K_g is large, which is consistent with the definition of Category 1 gases, such that the exponential term of Equation I-38 reduces to zero. The same result may be achieved by determining the conditions in which the third ratio of the right hand side of Equation I-38 reduces to 1. These conditions will be a function of the default values for respiratory tract surface area and minute volume as well as the absolute value of the overall mass transport coefficient. Using the definition of fp_{ET} results in the following dose ratio

$$RGDR_{TB} = \frac{(RGD_{TB})_A}{(RGD_{TB})_H} = \frac{\left(\frac{\dot{V}_E}{SA_{TB}}\right)_A}{\left(\frac{\dot{V}_E}{SA_{TB}}\right)_H} \frac{(e^{-K_{gET} \frac{SA_{ET}}{\dot{V}_E}})_A}{(e^{-K_{gET} \frac{SA_{ET}}{\dot{V}_E}})_H}, \quad (I-39)$$

which can be rearranged to

$$RGDR_{TB} = \frac{(RGD_{TB})_A}{(RGD_{TB})_H} = \frac{\left(\frac{\dot{V}_E}{SA_{TB}}\right)_A}{\left(\frac{\dot{V}_E}{SA_{TB}}\right)_H} \frac{\left(e^{-\frac{SA_{ET}}{\dot{V}_E}}\right)_A^{(K_{gET})_A}}{\left(e^{-\frac{SA_{ET}}{\dot{V}_E}}\right)_H^{(K_{gET})_H}} \quad (I-40)$$

If $(K_{gET})_A$ can be assumed to be equal to $(K_{gET})_H$, then Equation I-40 can be further simplified to

$$RGDR_{TB} = \frac{(RGD_{TB})_A}{(RGD_{TB})_H} = \frac{\left(\frac{\dot{V}_E}{SA_{TB}}\right)_A}{\left(\frac{\dot{V}_E}{SA_{TB}}\right)_H} \frac{\left[e^{-\frac{SA_{ET}}{\dot{V}_E}}\right]_A}{\left[e^{-\frac{SA_{ET}}{\dot{V}_E}}\right]_H}^{K_{gET}} \quad (I-41)$$

If K_{gET} is further assumed to be one, Equation I-41 reduces further such that only minute volume and surface areas are needed to evaluate the dose ratio, such that:

$$RGDR_{TB} = \frac{(RGD_{TB})_A}{(RGD_{TB})_H} = \frac{\left(\frac{\dot{V}_E}{SA_{TB}}\right)_A}{\left(\frac{\dot{V}_E}{SA_{TB}}\right)_H} \frac{\left[e^{-\frac{SA_{ET}}{\dot{V}_E}}\right]_A}{\left[e^{-\frac{SA_{ET}}{\dot{V}_E}}\right]_H}. \quad (I-42)$$

If K_{gET} is available for each species, Equation I-39 would be the preferred default equation.

I.2.4.3 Default Approach for Pulmonary Region

As discussed in Section I.2.3, the regional gas dose ratio for the PU region ($RGDR_{PU}$) is given by Equation I-35:

$$RGDR_{PU} = \frac{(RGD_{PU})_A}{(RGD_{PU})_H} = \frac{\left(\frac{K_{g_{PU}} SA_{PU}}{K_{g_{PU}} SA_{PU} + \dot{Q}_{alv}}\right)_A}{\left(\frac{K_{g_{PU}} SA_{PU}}{K_{g_{PU}} SA_{PU} + \dot{Q}_{alv}}\right)_H} \frac{\left(\frac{\dot{Q}_{alv}}{SA_{PU}}\right)_A}{\left(\frac{\dot{Q}_{alv}}{SA_{PU}}\right)_H} \frac{(fp_{TB})_A}{(fp_{TB})_H} \frac{(fp_{ET})_A}{(fp_{ET})_H}, \quad (I-35)$$

which at large $K_{g_{PU}}$ values reduces to

$$\text{RGDR}_{\text{PU}} = \frac{(\text{RGD}_{\text{PU}})_{\text{A}}}{(\text{RGD}_{\text{PU}})_{\text{H}}} = \frac{\left(\frac{\dot{Q}_{\text{alv}}}{\text{SA}_{\text{PU}}}\right)_{\text{A}} (f_{\text{pTB}})_{\text{A}} (f_{\text{pET}})_{\text{A}}}{\left(\frac{\dot{Q}_{\text{alv}}}{\text{SA}_{\text{PU}}}\right)_{\text{H}} (f_{\text{pTB}})_{\text{H}} (f_{\text{pET}})_{\text{H}}}. \quad (\text{I-43})$$

If the penetration fractions to each of the preceding regions are unknown due to lack of data on K_{gET} and K_{gTB} , the approach to deriving a default equation for the PU region is described below.

Using the definition of f_{pET} and f_{pTB} results in the following gas dose ratio for the PU region:

$$\text{RGDR}_{\text{PU}} = \frac{(\text{RGD}_{\text{PU}})_{\text{A}}}{(\text{RGD}_{\text{PU}})_{\text{H}}} = \frac{\left(\frac{\dot{Q}_{\text{alv}}}{\text{SA}_{\text{PU}}}\right)_{\text{A}} \left(e^{-K_{\text{gTB}} \frac{\text{SA}_{\text{TB}}}{\dot{V}_{\text{E}}}}\right)_{\text{A}} \left(e^{-K_{\text{gET}} \frac{\text{SA}_{\text{ET}}}{\dot{V}_{\text{E}}}}\right)_{\text{A}}}{\left(\frac{\dot{Q}_{\text{alv}}}{\text{SA}_{\text{PU}}}\right)_{\text{H}} \left(e^{-K_{\text{gTB}} \frac{\text{SA}_{\text{TB}}}{\dot{V}_{\text{E}}}}\right)_{\text{H}} \left(e^{-K_{\text{gET}} \frac{\text{SA}_{\text{ET}}}{\dot{V}_{\text{E}}}}\right)_{\text{H}}}, \quad (\text{I-44})$$

which can be rearranged to

$$\text{RGDR}_{\text{PU}} = \frac{(\text{RGD}_{\text{PU}})_{\text{A}}}{(\text{RGD}_{\text{PU}})_{\text{H}}} = \frac{\left(\frac{\dot{Q}_{\text{alv}}}{\text{SA}_{\text{PU}}}\right)_{\text{A}} \left[e^{-\frac{\text{SA}_{\text{TB}}}{\dot{V}_{\text{E}}}\left(K_{\text{gTB}}\right)_{\text{A}}}\right]_{\text{A}} \left[e^{-\frac{\text{SA}_{\text{ET}}}{\dot{V}_{\text{E}}}\left(K_{\text{gET}}\right)_{\text{A}}}\right]_{\text{A}}}{\left(\frac{\dot{Q}_{\text{alv}}}{\text{SA}_{\text{PU}}}\right)_{\text{H}} \left[e^{-\frac{\text{SA}_{\text{TB}}}{\dot{V}_{\text{E}}}\left(K_{\text{gTB}}\right)_{\text{H}}}\right]_{\text{H}} \left[e^{-\frac{\text{SA}_{\text{ET}}}{\dot{V}_{\text{E}}}\left(K_{\text{gET}}\right)_{\text{H}}}\right]_{\text{H}}}. \quad (\text{I-45})$$

If $(K_{\text{gET}})_{\text{A}}$ and $(K_{\text{gTB}})_{\text{A}}$ are assumed to be equal to $(K_{\text{gET}})_{\text{H}}$ and $(K_{\text{gTB}})_{\text{H}}$, respectively, then Equation I-45 can be further simplified to

$$\text{RGDR}_{\text{PU}} = \frac{(\text{RGD}_{\text{PU}})_{\text{A}}}{(\text{RGD}_{\text{PU}})_{\text{H}}} = \frac{\left(\frac{\dot{Q}_{\text{alv}}}{\text{SA}_{\text{PU}}} \right)_{\text{A}}}{\left(\frac{\dot{Q}_{\text{alv}}}{\text{SA}_{\text{PU}}} \right)_{\text{H}}} \left[\frac{\left(e^{-\frac{\text{SA}_{\text{TB}}}{\dot{V}_{\text{E}}}} \right)_{\text{A}}}{\left(e^{-\frac{\text{SA}_{\text{TB}}}{\dot{V}_{\text{E}}}} \right)_{\text{H}}} \right]^{K_{\text{gTB}}} \left[\frac{\left(e^{-\frac{\text{SA}_{\text{ET}}}{\dot{V}_{\text{E}}}} \right)_{\text{A}}}{\left(e^{-\frac{\text{SA}_{\text{ET}}}{\dot{V}_{\text{E}}}} \right)_{\text{H}}} \right]^{K_{\text{gET}}} \quad (1-46)$$

If it is further assumed that the value of K_{g} is equal to 1 for each region, the resulting default equation reduces to an equation requiring only surface area and minute ventilation parameters. It should be noted that as comparative transport studies become available, Equation I-45 would be preferable because it includes the differences in mass transport in each region for each species.

I.3 Model for Category 2 Gases

The Category 2 or "transitional" gases are those that have physicochemical properties that are likely to result in the gas significantly accumulating in blood. Accumulation in the blood will reduce the concentration driving force during inspiration and thereby reduce the absorption rate or dose upon inhalation. In addition, these gases are distinguished from Category 1 gases in that there exists the potential for significant desorption during exhalation. A back pressure (i.e., reversal of the concentration gradient at the air-liquid interface) may occur during expiration when the exhaled air concentration is less than the concentration of the surface liquid established during inspiration. Category 2 gases include those which are moderately water soluble. These gases may also either react rapidly and reversibly with the surface liquid or they may be moderately to slowly metabolized irreversibly in the respiratory tract.

A PBPK modeling approach as shown schematically in Figure I-5 is proposed to describe the determinants of absorption for this category of gas. A similar model with a more detailed description of blood flow has been proposed by Overton and Graham (1994). The PBPK approach is used to evaluate the steady-state blood concentration that is necessary to calculate both the absorption flux on inhalation and the desorption flux during exhalation.

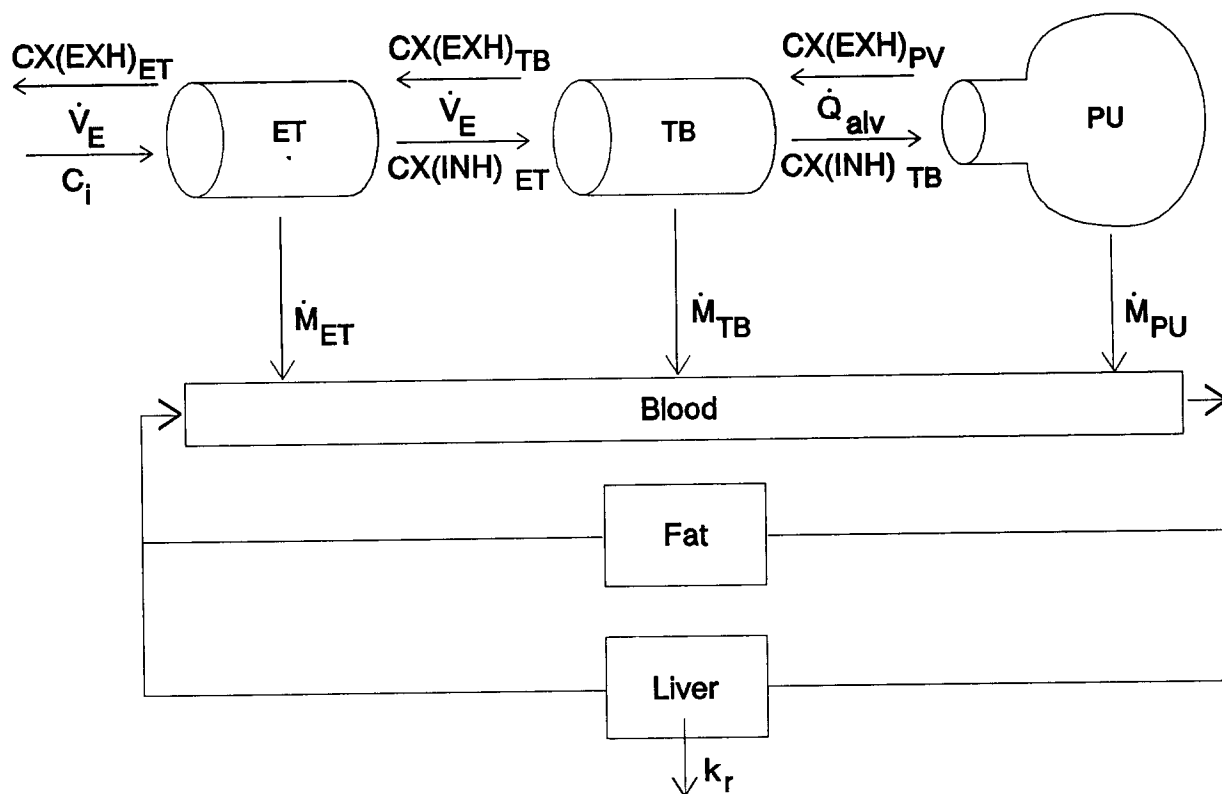

Figure I-5. Schematic of physiologically based pharmacokinetic modeling approach to estimate respiratory tract dose of gases in Category 2. The definitions for the parameter symbols are provided in Table I-1.

The derivation of the dose to the three respiratory tract regions will be developed in a similar fashion as that for Category 1 gases (Section I.2). Each region will be considered individually. Following the general description of the modeling approach for each region, a mass balance approach using a PBPK analysis will be developed to determine the blood concentration. A summary of the results and equations will be provided at the end of this section along with the default formulation.

I.3.1 Model for Category 2 Gases: Extrathoracic Region

As with the Category 1 gases, the change in concentration in the ET region (Section I.2.1) can be described by Equation I-9. If it is assumed that sufficient time has passed to allow a steady-state blood concentration to be developed, Equation I-9 can be integrated, resulting in Equation I-10. In the case of Category 1, the blood concentration was

assumed to be much less than the airstream or interfacial concentrations. For Category 2, however, the blood concentration must be retained. Thus, the fraction of gas that penetrates to the TB region is given by rearranging Equation I-10 such that:

$$fp_{ET} = e^{-K_{bET} \frac{SA_{ET}}{\dot{V}_E}} + \frac{C_{b/g}}{C_i} \left[1 - e^{-K_{bET} \frac{SA_{ET}}{\dot{V}_E}} \right]. \quad (I-47)$$

As defined in Equation I-16, the dose on inhalation to the ET region, $RGD(INH)_{ET}$, may be obtained by substituting Equation I-47 into Equation I-16 and rearranging to obtain

$$RGD(INH)_{ET} = \left[1 - \frac{C_{b/g}}{C_i} \right] (1 - e^{-K_{bET} \frac{SA_{ET}}{\dot{V}_E}}) \frac{C_i \dot{V}_E}{SA_{ET}}. \quad (I-48)$$

The form of the overall mass transport coefficient in Equation I-48 differs from that to describe Category 1 gases because a term to describe the disposition of the gas in blood is required. Approaches to include this term are reviewed by Ultman (1988). In the case where there is either no reaction or the reversible nature of the reaction can be handled by adjusting $H_{t/g}$ to be in equilibrium with the dissociated form of the gas, the mass transport coefficient for Category 2 gases may be determined from:

$$\frac{1}{K_{gET}} = \frac{1}{k_g} + \frac{1}{H_{t/g}k_l} + \frac{S_p}{H_{b/g}\dot{Q}_b}, \quad (I-49)$$

where S_p is the blood perfusion surface area, H_b is the blood:air partition coefficient, and Q_b is the local blood flow rate. The mass transport coefficient for gases, which are moderately to slowly metabolized in the tissue phase is given by

$$\frac{1}{K_{gET}} = \frac{1}{k_g} + \frac{1}{H_{t/g}k_l} + \frac{F}{H_{b/g}k_r V_{LG}}, \quad (I-50)$$

where F is the flux fraction reaching the blood, and V_{LG} is the volume of lung tissue. The flux fraction, F , is less than one if the absorbing gas reacts with constituents in the surface liquid and tissue phases.

Equation I-48 addresses the dose upon inhalation only. To evaluate the total dose, including events occurring during exhalation, the potential for desorption and the desorption flux must be evaluated. Desorption will reduce the total dose over a respiratory cycle; the dose associated with an observed effect is therefore less than that if only the dose on inhalation was considered. In the following section, the desorption term is developed by first considering the tissue depth in which desorption may influence tissue concentration and, by analogy, tissue dose.

I.3.1.1 Theoretical Considerations for Modeling Desorption

Empirical data has indicated that desorption can be important to estimating the respiratory tract dose (Gerde and Dahl, 1991; Dahl et al., 1991b). Unless the tissue concentration is greater than the exhalation airstream concentration, there will be no desorption during exhalation and, in fact, there is actually the potential for additional absorption. To evaluate the potential desorption, it is assumed that the blood concentration attains a relatively constant concentration independent of the respiratory flow cycle. Because it is assumed that the potential desorption will not impact the blood concentration, desorption will only impact the concentration profile in the tissue. The tissue concentration profile during exhalation is a function of the duration of exhalation. If desorption occurs, the surface-liquid/tissue concentration will decrease during exhalation, as will the concentration gradient between the air (gas phase) and blood. An example of the change in the tissue concentration profile that may occur during desorption is shown in Figure I-6.

In Figure I-6, the change in tissue concentration is shown to penetrate the entire surface-liquid/tissue phase as a result of the change in airstream concentration between inhalation and exhalation, $C(\text{INH})$ and $C(\text{EXH})$, respectively. The extent to which the tissue concentration profile changes is as yet unknown and must be evaluated to formulate the desorption term. To estimate the depth in the tissue that may be influenced by the change in flow direction and hence airstream concentration, an analytic solution is employed to evaluate the time course of the concentration profile in the tissue when the surface is exposed

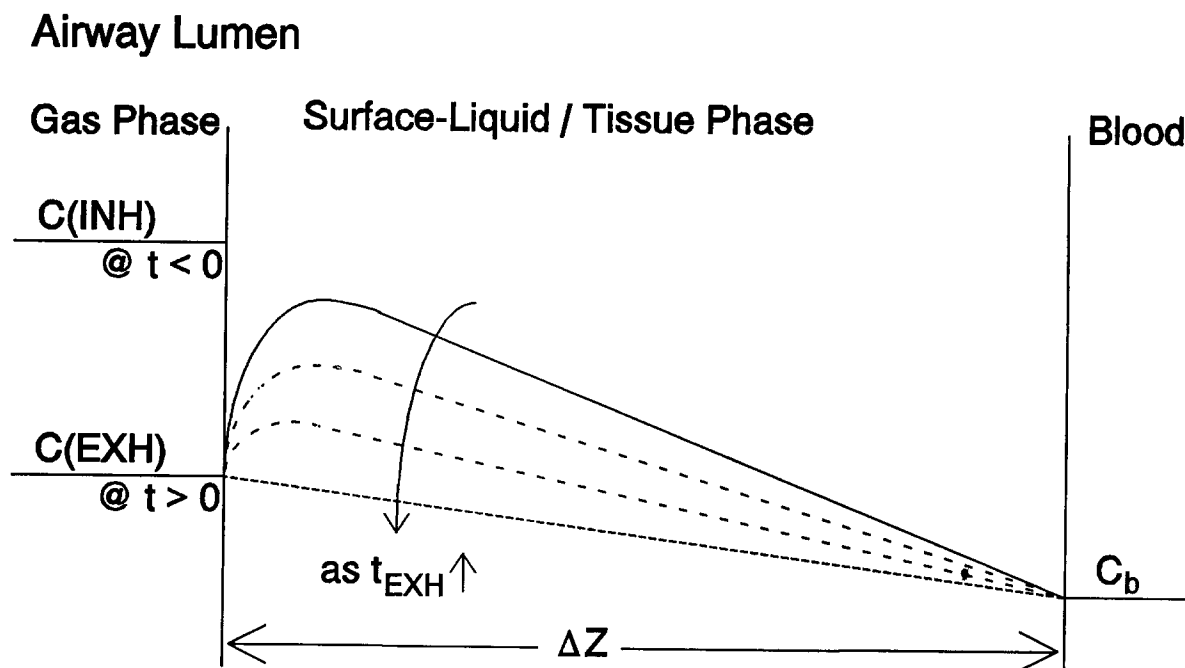

Figure I-6. Schematic of surface-liquid/tissue phase concentration during exhalation.

to a step change in concentration associated with the flow reversal. To avoid assumptions about the tissue thickness, it is assumed that the tissue is infinitely thick.

In Figure I-7, the initial conditions prior to imposing the step change is shown in which the tissue concentration is C_0 throughout. At time zero ($t=0$), the step change in the airstream concentration is imposed and the change in tissue concentration with distance and time is illustrated. Given the conditions described above and further assuming no reaction in the surface liquid-tissue layer, the solution is given in the form

$$\frac{(C_S - C_z)}{(C_S - C_0)} = \text{erf} \left[\frac{z}{2\sqrt{Dt}} \right], \quad (\text{I-51})$$

where C_S is the imposed concentration; C_z is the concentration in the surface liquid/tissue, which is a function of time (t) and distance into the layer (z); C_0 is the initial concentration;

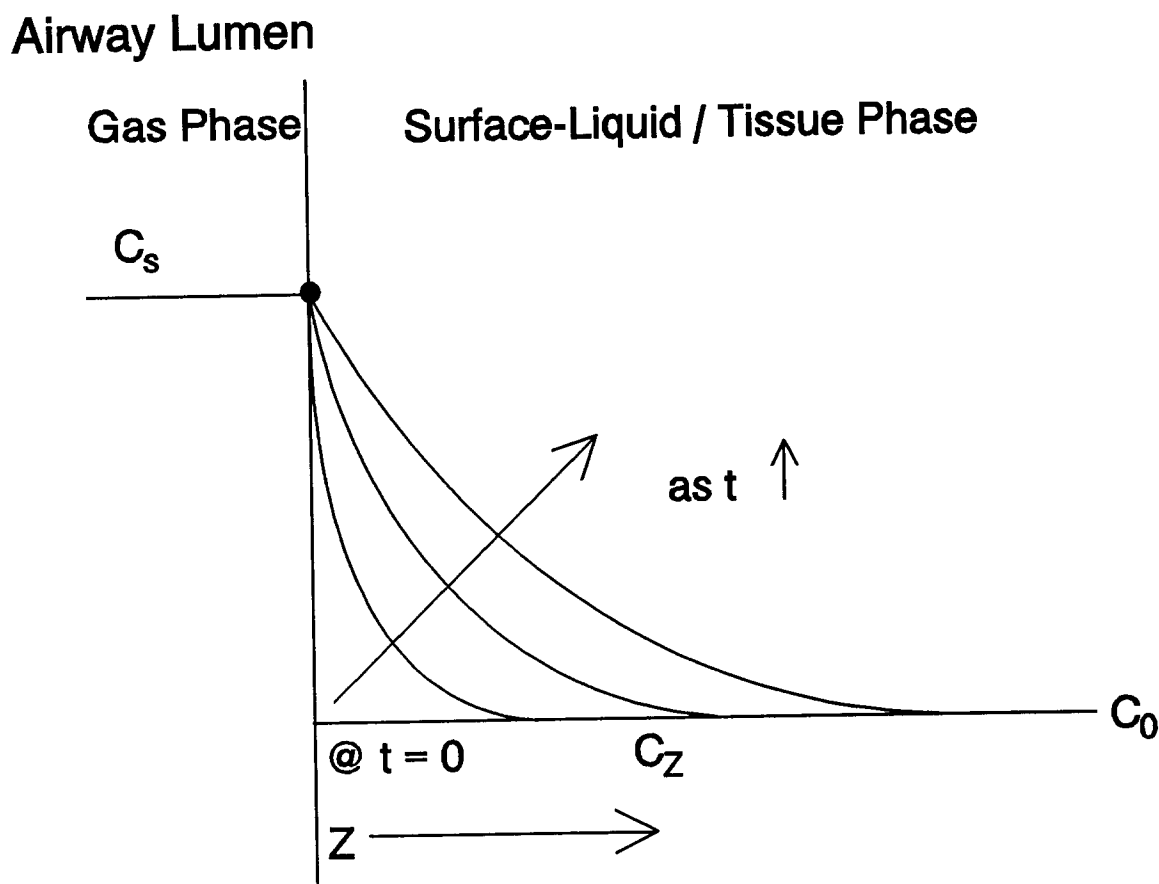

Figure I-7. Schematic of change in surface-liquid/tissue phase concentration with distance (z) and time.

and erf is the error function. The term on the left hand side of the equation is the nondimensional concentration such that, when C_z is in equilibrium with the gas phase concentration C_s , the nondimensional concentration is zero whereas when C_z is equal to C_0 , the nondimensional concentration is one.

To determine the depth to which the change in the surface concentration impacts the tissue concentration, the time for exhalation in humans is estimated to be approximately 3 s during rest. The time would decrease at increased ventilation rates. Using the above equation, the distance in which the nondimensional concentration attains 0.5 (i.e., the distance in which the local concentration is one-half the concentration difference) is determined to be approximately 70 μm . This distance represents significant penetration into the surface-liquid/tissue phase.

1.3.1.2 Formulation of the Desorption Term

The above estimate indicates that an imposed step change in air (gas phase) concentration as occurs during exhalation results in the tissue concentration at $70 \mu\text{m}$ attaining 50% of the equilibrium value within 3 s. Because this distance is of the order of the distance between the air-surface liquid/tissue interface and blood (Miller et al., 1985), it will be assumed in the derivation of the desorption term that the entire depth of the surface liquid-tissue phase between its interface with the gas phase and the blood may be impacted by desorption. Thus, a conservative assumption would be to assume that the gradient of an absorbing, nonreactive gas achieves a linear profile quickly during both inhalation and exhalation and that the gas phase transport resistance does not affect desorption. Therefore, the desorbed mass due to the flow reversal may be obtained by evaluating the change in mass necessary to effectively reduce the tissue gradient from the inhalation gradient to the exhalation gradient as indicated in Figure I-8.

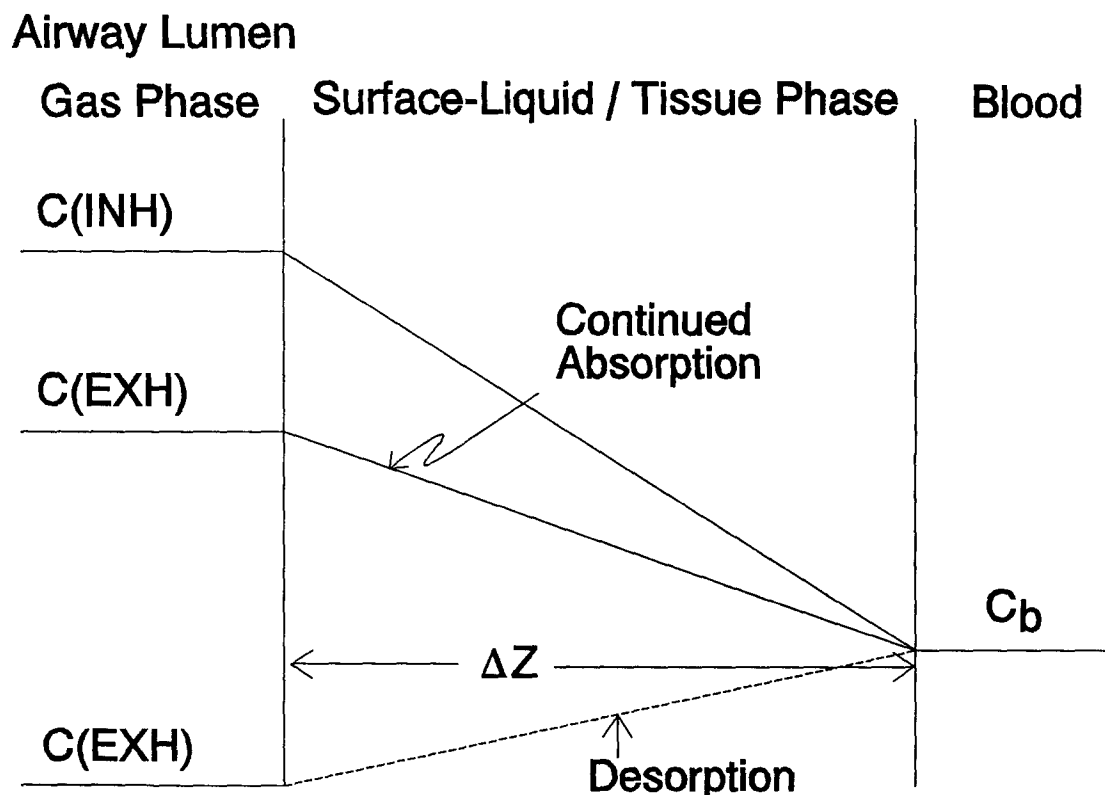

Figure I-8. Schematic of change in mass during breathing cycle.

In Figure I-8, two cases are noted with respect to the exhalation tissue concentration profile. In the first case, the exhalation airstream concentration, $C(\text{EXH})$, is greater than the concentration in equilibrium with the blood concentration. Consequently, the gradient is still directed inward such that absorption would continue during exhalation. However, there would be an initial loss of mass associated with the change in the concentration profile as shown in Figure I-6. The second case shown in Figure I-8 is that in which the $C(\text{EXH})$ is less than C_b , such that the gradient is directed outward. In this case, desorption occurs due to the step change in concentration associated with the flow reversal as well as a reversal in the concentration gradient between the air and blood. It is assumed, however, that the mass transferred during exhalation is associated primarily with achieving the exhalation tissue profile.

The desorbed mass (M_d) due to the step change in airstream concentration is therefore assumed to be determined by subtracting the average concentration represented by the tissue gradients between inspiration and expiration, such that

$$M_{d_{\text{ET}}} = \left(\frac{CX(\text{INH})_{\text{ET}} - CX(\text{EXH})_{\text{TB}}}{2} \right) \Delta Z_{\text{ET}} SA_{\text{ET}}, \quad (\text{I-52})$$

where ΔZ_{ET} is the surface-liquid/tissue phase thickness of the ET region. Because the blood concentration is assumed to be the same during inhalation and exhalation, it does not appear in the above equation.

In the case of a reactive gas, Equation I-52 will overestimate the desorbed mass because the concentration gradient is likely to be curvilinear and a decrease in the concentration profile would also be achieved by reaction and not through desorption. It is also possible that the reaction could be sufficient to effectively result in further absorption during exhalation due to the reduced tissue concentrations (similar to Case 2 described for Figure I-8). As an estimate of the desorbed mass of a reactive gas, an exponential decay term is added to Equation I-52 to account for the tissue reactivity, such that

$$M_{d_{ET}} = \left[\frac{CX(INH)_{ET} - CX(EXH)_{TB}}{2} \right] \Delta Z_{ET} SA_{ET} e^{-k_i(t_{EXH})}, \quad (I-53)$$

where t_{EXH} is the time of exhalation.

The regional desorbed dose (mass/cm² -time) during exhalation is therefore M_d divided by the product of the surface area and the exhalation time, such that

$$RGD(EXH)_{ET} = \frac{M_{d_{ET}}}{SA_{ET} t_{EXH}}. \quad (I-54)$$

The total dose in the ET region, accounting for both absorption during inhalation and desorption during exhalation, is therefore:

$$RGD(TOTAL)_{ET} = \frac{C_i \dot{V}_E}{SA_{ET}} \left[1 - \frac{C_{b/g}}{C_i} \right] (1 - e^{-K_{sET} \frac{SA_{ET}}{\dot{V}_E}}) - \frac{M_{d_{ET}}}{SA_{ET} t_{EXH}}. \quad (I-55)$$

I.3.2 Model for Category 2 Gases: Tracheobronchial Region

The model developed for the analysis of total dose to the ET region for gases in Category 2 is directly applicable to the determination of the total dose to the TB region, such that

$$RGD(TOTAL)_{TB} = \frac{CX(INH)_{ET} \dot{V}_E}{SA_{TB}} \left[1 - \frac{C_{b/g}}{CX(INH)_{ET}} \right] (1 - e^{-K_{sTB} \frac{SA_{TB}}{\dot{V}_E}}) - \frac{M_{d_{TB}}}{SA_{TB} t_{EXH}}, \quad (I-56)$$

where the desorbed mass is similarly defined as above. Thus, for gases that do not react irreversibly, M_d is given by:

$$M_{d_{TB}} = \left[\frac{CX(INH)_{TB} - CX(EXH)_{PU}}{2} \right] \Delta Z_{TB} SA_{TB}, \quad (I-57)$$

and for those gases that do react irreversibly M_d is given by

$$M_{d_{TB}} = \left[\frac{CX(INH)_{TB} - CX(EXH)_{PU}}{2} \right] \Delta Z_{TB} SA_{TB} e^{-k_r(t_{EXH})}. \quad (I-58)$$

where ΔZ_{TB} is surface-liquid/tissue phase thickness of the TB region.

Substituting for $CX(INH)_{ET}$ using Equation I-47 and the definition of f_{PET} , Equation I-56 becomes

$$RGD(TOTAL)_{TB} = \frac{C_i \dot{V}_E}{SA_{TB}} e^{-\frac{K_{gET} SA_{ET}}{\dot{V}_E}} \left[1 - \frac{C_{b/g}}{C_i} \right] \left(1 - e^{-\frac{K_{gTB} SA_{TB}}{\dot{V}_E}} \right) - \frac{M_{d_{TB}}}{SA_{TB} t_{EXH}}. \quad (I-59)$$

I.3.3 Model for Category 2 Gases: Pulmonary Region

The dose to the PU region for the Category 2 gases may be derived on the basis of equations provided previously (Section I.2.3). From Equation I-30 the ratio of the expired concentration to the inspired concentration of this region (i.e., the penetration fraction of the PU region) is defined as

$$\frac{CX(EXH)_{PU}}{CX(INH)_{TB}} = \frac{\dot{Q}_{alv}}{K_{gPU} SA_{PU} \left[1 - \frac{C_{b/g}}{CX(EXH)_{PU}} \right] + \dot{Q}_{alv}}, \quad (I-60)$$

where $CX(EXH)_{PU}$ is the concentration exiting the PU region and therefore includes the desorption term.

In the previous section describing PU dose (Section I.2.3), K_{gPU} is defined only for a reactive gas (Equation I-28). However, for gases that are nonreactive or reversibly reactive, a more appropriate form would be (Ultman, 1988)

$$\frac{1}{K_{g_{PU}}} = \frac{1}{H_{t/g} k_l SA_{PU}} + \frac{S_p}{H_{b/g} Q_b}. \quad (I-61)$$

The PU dose as defined for Category 1 gases was based on the assumption that $C_{b/g}$ was less than C_{alv} . This assumption is not applicable to the transitional gases of Category 2 because of the potential for elevated blood concentrations. Consequently, the total dose to the PU region for these gases is defined as

$$RGD(TOTAL)_{PU} = \left[1 - \frac{\dot{Q}_{alv}}{[K_{g_{PU}} SA_{PU} \left(1 - \frac{C_{b/g}}{CX(EXH)_{PU}} \right) + \dot{Q}_{alv}]} \right] \frac{\dot{Q}_{alv}}{SA_{PU}} CX(INH)_{TB} \quad (I-62)$$

Equation I-62, although the most general form of the PU dose, can also be formulated more simply by assuming

$$C_{alv} = CX(EXH)_{PU} = C_{b/g} \quad (I-63)$$

because Category 2 gases are moderately water soluble and likely to reach equilibrium between alveolar air concentration and the blood. Under these conditions, the PU dose is simply the difference between the inhaled concentration, $CX(INH)_{TB}$, and the exhaled concentration, $CX(EXH)_{PU}$, such that

$$RGD(TOTAL)_{PU} = \frac{CX(INH)_{TB} - CX(EXH)_{PU}}{SA_{PU}} \dot{Q}_{alv}, \quad (I-64)$$

which by substitution for $CX(INH)_{TB}$ and $CX(EXH)_{PU}$ rearranges to

$$\text{RGD(TOTAL)}_{\text{PU}} = C_i \frac{\dot{Q}_{\text{alv}}}{\text{SA}_{\text{PU}}} \left[\left(1 - \frac{C_{\text{b/g}}}{C_i} \right) \left(e^{-\frac{K_{\text{ET}} \text{SA}_{\text{ET}}}{\dot{V}_E}} \right) \left(e^{-\frac{K_{\text{TB}} \text{SA}_{\text{TB}}}{\dot{V}_E}} \right) \right] \quad (\text{I-65})$$

Equation I-65 represents the most generalized equation resulting from the simplifying assumption that the PU dose is proportional to the difference between the inhaled and exhaled concentrations.

I.3.4 Modeling the Blood Compartment for Category 2 Gases

As defined, Category 2 gases will accumulate in the blood. Thus, an explicit derivation to determine concentration of the gas in the blood is required to solve for the dose into each region. In particular, the term that must be evaluated is $(1 - C_{\text{b/g}}/C_i)$, which appears in each of the equations necessary to solve the regional dose. This term includes the blood concentration because $C_{\text{b/g}}$ is the concentration in the gas phase which would be in equilibrium with the blood (i.e., $C_{\text{b/g}} = C_{\text{b}}/H_{\text{b/g}}$).

The blood concentration is derived by a mass balance approach. It is assumed that the systemic blood compartment is well mixed so that the change in concentration is due to the input mass delivered through the respiratory tract, loss due to metabolism in the lung tissue, redistribution of the gas in the systemic compartments (including the fat compartment) during intermittent exposures, and loss due to systemic metabolism (modeled in the liver compartment), such that

$$V_{\text{b}} \frac{dC_{\text{b}}}{dt} = \Sigma(\text{RGD(TOT)}_{\text{RT}} \text{SA(TOT)}_{\text{RT}}) - C_{\text{art}}(\text{CL}_{\text{sys}} + \text{CL}_{\text{fat}}) - V_{\text{LG}} \dot{E}_{\text{LG}} \quad (\text{I-66})$$

where V_{b} and V_{LG} are the volumes of the blood and lung compartments, respectively, C_{b} is the average blood concentration; $\Sigma(\text{RGD(TOT)}_{\text{RT}} \text{SA(TOT)}_{\text{RT}})$ is the summed product of the dose and surface area of each region in the respiratory tract; C_{art} is the arterial blood concentration; CL_{sys} and CL_{fat} are the clearance from the systemic (i.e., assumed to be dominated by the liver compartment) and the fat compartments, respectively; and \dot{E}_{LG} is the elimination rate in the lung compartment due to metabolism. The total mass transport rate to

the respiratory tract (mass/time) is given in the above equation as the summed product of the dose and surface area of each region in the respiratory tract. However, the total dose to the respiratory tract may also be obtained by the difference in inhalation and exhalation concentrations, such that

$$\Sigma (\text{RGD}(\text{TOT})_{\text{RT}} \text{SA}(\text{TOT})_{\text{RT}}) = \dot{V}_E (C_i - \text{CX}(\text{EXH})_{\text{ET}}). \quad (\text{I-67})$$

The term that implicitly includes the blood concentration and is necessary to solve regional dose is obtained from Equation I-67. Ignoring further absorption or desorption that may occur during expiration, $\text{CX}(\text{EXH})_{\text{ET}}$ may be approximated by $\text{CX}(\text{EXH})_{\text{PU}}$, which is equivalent to C_{alv} , the alveolar concentration, which is in equilibrium with the blood (Equation I-63). Thus

$$\dot{V}_E (C_i - \text{CX}(\text{EXH})_{\text{ET}}) = \dot{V}_E C_i \left(1 - \frac{C_{\text{b/g}}}{C_i}\right). \quad (\text{I-68})$$

To determine the respiratory tract dose during the exposure, it will be assumed that the system is in quasi-steady state such that the change in the average blood concentration (dC_b/dt) is zero (Equation I-66). Under these conditions, the mass delivery rate to the respiratory tract surface (defined in Equation I-67) is equal to the loss due to clearance from the liver and fat as well as metabolism in the respiratory tract tissue. Combining Equations I-66 through I-68 under steady state conditions results in

$$\dot{V}_E (C_i - C_{\text{alv}}) = C_{\text{art}}(\text{CL}_{\text{sys}} + \text{CL}_{\text{fat}}) + V_{\text{LG}} \dot{E}_{\text{LG}}. \quad (\text{I-69})$$

This relationship, however, can be further reduced for Category 2 gases.

In the case of gases that are relatively insoluble in water (Category 3, Appendix J), the fat compartment plays an important role in the distribution of the gas. The fat compartment may absorb mass at the start of and/or during an intermittent exposure and therefore

represents an additional loss from the arterial blood concentration. At the end of the exposure, leaching from the fat compartment may be an additional input to the blood. Because the initial dose of gases with respiratory toxicity accounts for the dose that may be leached subsequently from the fat, no additional dose following the end of exposure needs to be accounted for. Furthermore, the contribution of the fat compartment is reduced for Category 2 gases because the gas will not partition significantly to the fat because of its lower fat to blood partition coefficient. In addition, the concentrations in the systemic compartments are in equilibrium with the blood during steady state. Thus, the uptake by the fat will be assumed zero, consistent with the definition Category 2 gases because of their partition coefficient. The assumption of a steady state is conservative because it will underestimate the dose to the respiratory tract compartments that are the objective of the derivation in this appendix. The assumptions of steady state and of equilibrium between tissue and blood compartments results in the elimination of CL_{fat} from Equation I-69.

Rearranging Equation I-69 to solve for systemic elimination results in

$$CL_{sys} = \dot{V}_E \frac{(C_i - C_{alv})}{C_{art}} - \frac{V_{LG}\dot{E}_{LG}}{C_{art}}, \quad (I-70)$$

where CL_{fat} is zero as described above. However, the ratio of the exhaled concentration, C_{alv} , to C_{art} is approximated by $H_{b/g}$. Equation I-70 may therefore be rewritten as

$$CL_{sys} = \dot{V}_E \left(\frac{1}{H_{EFF}} - \frac{1}{H_{b/g}} \right) - \frac{V_{LG}\dot{E}_{LG}}{C_{art}}, \quad (I-71)$$

where H_{EFF} is the steady state blood to inhaled gas concentration ratio observed in an experimental situation (Andersen, 1981), which is referred to here as an effective partition coefficient.

It is now necessary to more specifically incorporate the loss terms for systemic clearance and respiratory tract metabolism. It will be assumed that systemic clearance is

predominately due to metabolism in the liver and is given by (Andersen, 1981; Pang and Rowland, 1977)

$$CL_{\text{sys}} \approx CL_{\text{LIV}} = \dot{Q}_T E_T, \quad (\text{I-72})$$

where CL_{LIV} is the clearance from the liver compartment; \dot{Q}_T is the cardiac output; and E_T is the liver extraction efficiency. The elimination rate from the lung compartment, \dot{E}_{LG} , is defined according to Michaelis-Menton kinetics:

$$\dot{E}_{\text{LG}} = \frac{C_{\text{LG}} V_{\text{MAX}}}{(KM + C_{\text{LG}})} = k_{\text{LG}} C_{\text{LG}}, \quad (\text{I-73})$$

where V_{MAX} is the maximum velocity of saturable (Michaelis-Menton) metabolism path; where C_{LG} is the lung tissue concentration; KM is the Michaelis constant; and k_{LG} is the elimination rate from the lung compartment.

Combining Equations I-71 to I-73 provides the loss terms in relation to H_{EFF} :

$$\dot{Q}_T E_T = \dot{V}_E \left(\frac{1}{H_{\text{EFF}}} - \frac{1}{H_{\text{b/g}}} \right) - V_{\text{LG}} k_{\text{LG}} \frac{C_{\text{LG}}}{C_{\text{art}}}. \quad (\text{I-74})$$

Assuming the respiratory tract tissue concentration, C_{LG} , is in equilibrium with the blood, the ratio $C_{\text{LG}}/C_{\text{art}}$ is equivalent to the tissue:blood partition coefficient, $H_{\text{t/b}}$. Solving for H_{EFF} yields

$$H_{\text{EFF}} = \frac{\dot{V}_E}{\dot{Q}_T E_T + V_{\text{LG}} k_{\text{LG}} H_{\text{t/b}} + \frac{\dot{V}_E}{H_{\text{b/g}}}}. \quad (\text{I-75})$$

Combining Equation I-68 with the definition of $H_{\text{b/g}}$ and H_{EFF} results in

$$\dot{V}_E C_i \left(1 - \frac{C_{b/g}}{C_i}\right) = \dot{V}_E (C_i - C_{alv}) = \dot{V}_E C_i \left(\frac{H_{b/g} - H_{EFF}}{H_{b/g}}\right). \quad (I-76)$$

Upon substitution of I-75 into I-76, the term necessary to solve the dose ratio in Equations I-55, I-59, and I-65 is obtained:

$$\left(1 - \frac{C_{b/g}}{C_i}\right) = \frac{\dot{Q}_T E_T H_{b/g} + V_{LG} k_{LG} H_{t/b} H_{b/g}}{\dot{Q}_T E_T H_{b/g} + V_{LG} k_{LG} H_{t/b} H_{b/g} + \dot{V}_E}, \quad (I-77)$$

where $H_{t/g}$ is equal to the product of $H_{t/b}$ and $H_{b/g}$. Equation I-77 may be simplified by considering the range of partition coefficients, extraction efficiency and the respiratory tract tissue concentration.

At large values of $H_{t/g}$ (and consequently $H_{b/g}$ since $H_{b/t} \times H_{t/g} = H_{b/g}$), the term on the right hand side of Equation I-77 approximates one. Therefore, $C_{b/g} \ll C_i$ which is the definition of Category 1 gases (i.e., those gases that are highly soluble and/or rapidly irreversibly reactive) for which the approach presented in Section I.2.4 applies. This case is consistent with a greater extraction efficiency of the respiratory tract relative to the systemic clearance as well as absorption proximal to the PU region. Conversely, at low values of $H_{t/g}$, absorption proximal to the PU region is negligible and the relative efficiency of systemic clearance is greater than that of the respiratory tract extraction (as well as uptake). The approach for category 3 gases presented in Appendix J applies in this case.

The remaining gases are those which are moderately water soluble (intermediate value of $H_{t/g}$) and are therefore the Category 2 gases. For Category 2 gases, Equation I-77 reduces to

$$\left(1 - \frac{C_{b/g}}{C_i}\right) = \frac{\dot{Q}_T}{\dot{V}_E} E_T H_{b/g} \left(1 + \frac{V_{LG} k_{LG} H_{t/b}}{\dot{Q}_T E_T}\right). \quad (I-78)$$

since $\dot{V}_E / \dot{Q}_T H_{b/g} \gg E_T + (V_{LG} k_{LG} / \dot{Q}_T) H_{t/b}$.

Equation I-78 can be further reduced since \dot{Q}_T approximates \dot{V}_E . The magnitude of the blood concentration is determined by the relative significance of the metabolism which occurs in the respiratory tract versus systemic elimination (as shown in the ratio $V_{LG}k_{LG}H_{t/b}/\dot{Q}_TE_T$). If systemic elimination is much larger, Equation I-78 reduces to

$$\left(1 - \frac{C_{b/g}}{C_i}\right) = E_T H_{b/g} . \quad (I-79)$$

At the maximum, it will be assumed that the respiratory tract elimination would be equal to that of the systemic elimination under which circumstances

$$\left(1 - \frac{C_{b/g}}{C_i}\right) = 2E_T H_{b/g} . \quad (I-80)$$

It will be further assumed that the systemic elimination term is defined for maximum elimination, i.e. assuming liver saturation kinetics, such that E_T is defined by E_{MAX} , the maximum extraction efficiency. The maximum extraction efficiency is approximately $0.25\dot{Q}_T$ due to the flow limitation to the liver (Andersen, 1981). Thus, Category 2 gases can be defined based on systemic elimination and the relative significance of respiratory tract metabolism to systemic elimination.

I.3.5 Default Approach for Category 2 Gases

The default approach is developed by ignoring the desorption associated with exhalation. This assumption may be valid in as much as the mass in the tissue that is desorbed during exhalation is replaced on inhalation. Whether, in general, this assumption results in an overestimate or underestimate of the dose is not clear because ignoring the desorbed mass may not significantly impact the concentration driving force (i.e., the concentration of the gas at the surface-liquid/tissue interface and the concentration in the blood may be proportionately affected).

In comparing cyclic absorption-desorption and unidirectional absorption, the concentration at the interface between the air and surface liquid is likely to be lower in the

case of desorption and the driving force would therefore be lower than in the case of unidirectional absorption if the blood concentration were equal in both cases. The net effect would suggest that ignoring desorption would overestimate the absorbed mass or dose. However, by overestimating the absorbed mass in the case of unidirectional absorption, the blood concentration will be elevated over the absorption-desorption case. The elevated blood concentration will also reduce the concentration driving force. Therefore, although ignoring desorption will increase the surface liquid concentrations, the blood concentration will similarly be overestimated, so that the concentration driving force may not be dissimilar than with desorption described.

The dose to each region, ignoring desorption, is therefore obtained by combining Equation I-79 or I-80 (depending on the significance of respiratory tract metabolism) with each of the individual dosimetry calculations in Equations I-55, I-59, and I-65 for the ET, TB, and PU regions, respectively.

I.3.5.1 Default Approach for Extrathoracic Region

From Equation I-54, the regional gas dose ratio (ignoring desorption) for the ET region ($RGDR_{ET}$) is given by

$$RGDR_{ET} = \frac{(RGD_{ET})_A}{(RGD_{ET})_H} = \frac{\left(\frac{C_i \dot{V}_E}{SA_{ET}}\right)_A \left(1 - \frac{C_{b/g}}{C_i}\right)_A \left(1 - e^{-K_{gET} \frac{SA_{ET}}{\dot{V}_E}}\right)_A}{\left(\frac{C_i \dot{V}_E}{SA_{ET}}\right)_H \left(1 - \frac{C_{b/g}}{C_i}\right)_H \left(1 - e^{-K_{gET} \frac{SA_{ET}}{\dot{V}_E}}\right)_H} \quad (I-81)$$

However, K_{gET} for Category 2 gases is by definition less than 1. Assuming K_{gET} is equal to or less than 0.5, a power series expansion of the exponential term results in the following relationship:

$$\text{RGDR}_{\text{ET}} = \frac{(\text{RGD}_{\text{ET}})_{\text{A}}}{(\text{RGD}_{\text{ET}})_{\text{H}}} = \frac{(C_i \frac{\dot{V}_E}{\text{SA}_{\text{ET}}})_{\text{A}} (1 - \frac{C_{\text{b/g}}}{C_i})_{\text{A}} (-K_{\text{g}_{\text{ET}}})_{\text{A}} \frac{\text{SA}_{\text{ET}}}{\dot{V}_E}_{\text{A}}}{(C_i \frac{\dot{V}_E}{\text{SA}_{\text{ET}}})_{\text{H}} (1 - \frac{C_{\text{b/g}}}{C_i})_{\text{H}} (-K_{\text{g}_{\text{ET}}})_{\text{H}} \frac{\text{SA}_{\text{ET}}}{\dot{V}_E}_{\text{H}}}. \quad (\text{I-82})$$

Assuming the same inspired concentration, simplifies the RGDR_{ET} to

$$\text{RGDR}_{\text{ET}} = \frac{(\text{RGD}_{\text{ET}})_{\text{A}}}{(\text{RGD}_{\text{ET}})_{\text{H}}} = \frac{K_{\text{g}_{\text{ETA}}}}{K_{\text{g}_{\text{ETH}}}} \frac{(1 - \frac{C_{\text{b/g}}}{C_i})_{\text{A}}}{(1 - \frac{C_{\text{b/g}}}{C_i})_{\text{H}}}. \quad (\text{I-83})$$

If the overall mass transport coefficients ($K_{\text{g}_{\text{ET}}}$) are assumed equal as in the case of Category 1 gases, the regional gas dose ratio is reduced to the ratio of $(1 - C_{\text{b/g}}/C_i)$.

Two cases were developed for the derivation of the blood term as expressed in Equations I-79 and I-80. The first case in which systemic elimination is assumed to be much greater than respiratory tract metabolism such that

$$\text{RGDR}_{\text{ET}} = \frac{(\text{RGD}_{\text{ET}})_{\text{A}}}{(\text{RGD}_{\text{ET}})_{\text{H}}} = \frac{K_{\text{g}_{\text{ETA}}}}{K_{\text{g}_{\text{ETH}}}} \frac{(0.25 \dot{Q}_T H_{\text{b/g}})_{\text{A}}}{(0.25 \dot{Q}_T H_{\text{b/g}})_{\text{H}}}, \quad (\text{I-84})$$

and the second case in which respiratory tract metabolism is assumed to be of equal significance with systemic elimination such that

$$\text{RGDR}_{\text{ET}} = \frac{(\text{RGD}_{\text{ET}})_{\text{A}}}{(\text{RGD}_{\text{ET}})_{\text{H}}} = \frac{K_{\text{g}_{\text{ETA}}}}{K_{\text{g}_{\text{ETH}}}} \frac{(0.5 \dot{Q}_T H_{\text{b/g}})_{\text{A}}}{(0.5 \dot{Q}_T H_{\text{b/g}})_{\text{H}}}, \quad (\text{I-85})$$

where E_{MAX} is equal to $0.25 \dot{Q}_T$. Because the constants are equal in the numerator and denominator, Equations I-84 and I-85 reduce to the same equation:

$$RGDR_{ET} = \frac{(RGD_{ET})_A}{(RGD_{ET})_H} = \frac{K_{g_{ETA}}}{K_{g_{ETH}}} \frac{(\dot{Q}_T H_{b/g})_A}{(\dot{Q}_T H_{b/g})_H}, \quad (I-86)$$

which can be further reduced if the overall mass transport coefficients ($K_{g_{ET}}$) are assumed to be equal.

I.3.5.2 Default Approach for Tracheobronchial Region

From Equation I-58, the regional gas dose ratio (ignoring desorption) for the tracheobronchial region ($RGDR_{TB}$) is given by

$$RGDR_{TB} = \frac{(RGD_{TB})_A}{(RGD_{TB})_H} = \frac{(C_i \frac{\dot{V}_E}{SA_{TB}})_A}{(C_i \frac{\dot{V}_E}{SA_{TB}})_H} \frac{(e^{-K_{g_{ET}} \frac{SA_{ET}}{\dot{V}_E}})_A}{(e^{-K_{g_{ET}} \frac{SA_{ET}}{\dot{V}_E}})_H} \frac{(1 - \frac{C_{b/a}}{C_i})_A}{(1 - \frac{C_{b/a}}{C_i})_H} \frac{(1 - e^{-K_{g_{TB}} \frac{SA_{TB}}{\dot{V}_E}})_A}{(1 - e^{-K_{g_{TB}} \frac{SA_{TB}}{\dot{V}_E}})_H}. \quad (I-87)$$

As in the ET region, $K_{g_{TB}}$ for Category 2 gases is by definition less than 1 and a power series expansion of the exponential term for the TB region similarly reduces the last term to the ratio of the $K_{g_{TB}}$. The exponential term for the ET term in Equation I-86 is reduced by assuming $K_{g_{ET}}$ is the same for each species as was assumed for Category 1 gases. At values of $K_{g_{ET}}$ less than or equal 0.5, the ET exponential term approaches one. Thus, assuming the same inspired concentrations, Equation I-86 becomes

$$RGDR_{TB} = \frac{(RGD_{TB})_A}{(RGD_{TB})_H} = \frac{K_{g_{TBA}}}{K_{g_{TBH}}} \frac{(1 - \frac{C_{b/a}}{C_i})_A}{(1 - \frac{C_{b/a}}{C_i})_H}. \quad (I-88)$$

As above, Equation I-88 is further reduced by substituting Equation I-79 for the case in which systemic elimination predominates:

$$\text{RGDR}_{\text{TB}} = \frac{(\text{RGD}_{\text{TB}})_{\text{A}}}{(\text{RGD}_{\text{TB}})_{\text{H}}} = \frac{K_{g_{\text{TB}A}}}{K_{g_{\text{TB}H}}} \frac{(0.25 \dot{Q}_{\text{T}} H_{\text{b/a}})_{\text{A}}}{(0.25 \dot{Q}_{\text{T}} H_{\text{b/a}})_{\text{H}}} . \quad (\text{I-89})$$

By substituting Equation I-80 for the case in which respiratory tract metabolism and systemic elimination are of equal significance, Equation I-88 becomes:

$$\text{RGDR}_{\text{TB}} = \frac{(\text{RGD}_{\text{TB}})_{\text{A}}}{(\text{RGD}_{\text{TB}})_{\text{H}}} = \frac{K_{g_{\text{TB}A}}}{K_{g_{\text{TB}H}}} \frac{(0.5 \dot{Q}_{\text{T}} H_{\text{b/a}})_{\text{A}}}{(0.5 \dot{Q}_{\text{T}} H_{\text{b/a}})_{\text{H}}} , \quad (\text{I-90})$$

where E_{MAX} is equal to $0.25 \dot{Q}_{\text{T}}$. Because the constants are equal in the numerator and denominator, Equations I-89 and I-90 reduce to the same equation:

$$\text{RGDR}_{\text{TB}} = \frac{(\text{RGD}_{\text{TB}})_{\text{A}}}{(\text{RGD}_{\text{TB}})_{\text{H}}} = \frac{K_{g_{\text{TB}A}}}{K_{g_{\text{TB}H}}} \frac{(\dot{Q}_{\text{T}} H_{\text{b/a}})_{\text{A}}}{(\dot{Q}_{\text{T}} H_{\text{b/a}})_{\text{H}}} , \quad (\text{I-91})$$

which can be further reduced if the overall mass transport coefficients ($K_{g_{\text{TB}}}$) are assumed to be equal.

I.3.5.3 Default Approach for Pulmonary Region

From Equation I-64, the regional gas dose ratio (ignoring desorption) for the PU region (RGDR_{PU}) is given by

$$\text{RGDR}_{\text{PU}} = \frac{(\text{RGD}_{\text{PU}})_{\text{A}}}{(\text{RGD}_{\text{PU}})_{\text{H}}} = \frac{(C_i \frac{\dot{Q}_{\text{alv}}}{SA_{\text{PU}}})_{\text{A}}}{(C_i \frac{\dot{Q}_{\text{alv}}}{SA_{\text{PU}}})_{\text{H}}} \frac{(e^{-K_{\text{ET}} \frac{SA_{\text{ET}}}{\dot{V}_{\text{E}}}})_{\text{A}}}{(e^{-K_{\text{ET}} \frac{SA_{\text{ET}}}{\dot{V}_{\text{E}}}})_{\text{H}}} \frac{(e^{-K_{\text{ETB}} \frac{SA_{\text{TB}}}{\dot{V}_{\text{E}}}})_{\text{A}}}{(e^{-K_{\text{ETB}} \frac{SA_{\text{TB}}}{\dot{V}_{\text{E}}}})_{\text{H}}} \frac{(1 - \frac{C_{\text{b/a}}}{C_i})_{\text{A}}}{(1 - \frac{C_{\text{b/a}}}{C_i})_{\text{H}}} . \quad (\text{I-92})$$

The default ratio is obtained by assuming the mass transport coefficients for the ET and the TB region are the same in each species. The exponential term for both the ET and TB term in Equation I-90 thereby reduces to one. Thus, assuming the same inspired concentrations, Equation I-90 becomes

$$\text{RGDR}_{\text{PU}} = \frac{(\text{RGD}_{\text{PU}})_{\text{A}}}{(\text{RGD}_{\text{PU}})_{\text{H}}} = \frac{\left(\frac{\dot{Q}_{\text{alv}}}{\text{SA}_{\text{PU}}}\right)_{\text{A}} \left(1 - \frac{C_{\text{b/a}}}{C_{\text{i}}}\right)_{\text{A}}}{\left(\frac{\dot{Q}_{\text{alv}}}{\text{SA}_{\text{PU}}}\right)_{\text{H}} \left(1 - \frac{C_{\text{b/a}}}{C_{\text{i}}}\right)_{\text{H}}} \quad (\text{I-93})$$

The RGDR_{PU} must be evaluated for each case described in section I.3.4. In the case where systemic elimination determines the blood term, the PU regional gas dose ratio is given by

$$\text{RGDR}_{\text{PU}} = \frac{(\text{RGD}_{\text{PU}})_{\text{A}} \left(\frac{\dot{Q}_{\text{alv}}}{\text{SA}_{\text{PU}}}\right)_{\text{A}} (0.25 \dot{Q}_{\text{T}} H_{\text{b/g}})_{\text{A}}}{(\text{RGD}_{\text{PU}})_{\text{H}} \left(\frac{\dot{Q}_{\text{alv}}}{\text{SA}_{\text{PU}}}\right)_{\text{H}} (0.25 \dot{Q}_{\text{T}} H_{\text{b/g}})_{\text{H}}} \quad (\text{I-94})$$

where E_{MAX} is equal to $0.25 \dot{Q}_{\text{T}}$.

In the case where respiratory tract metabolism and systemic elimination are equally important, the PU regional gas dose ratio is given by

$$\text{RGDR}_{\text{PU}} = \frac{(\text{RGD}_{\text{PU}})_{\text{A}} \left(\frac{\dot{Q}_{\text{alv}}}{\text{SA}_{\text{PU}}}\right)_{\text{A}} (0.5 \dot{Q}_{\text{T}} H_{\text{b/g}})_{\text{A}}}{(\text{RGD}_{\text{PU}})_{\text{H}} \left(\frac{\dot{Q}_{\text{alv}}}{\text{SA}_{\text{PU}}}\right)_{\text{H}} (0.5 \dot{Q}_{\text{T}} H_{\text{b/g}})_{\text{H}}} \quad (\text{I-95})$$

where E_{MAX} is equal to $0.25 \dot{Q}_{\text{T}}$. Because the constants are equal in the numerator and denominator, Equations I-94 and I-95 reduce to the same equation:

$$\text{RGDR}_{\text{PU}} = \frac{(\text{RGD}_{\text{PU}})_{\text{A}}}{(\text{RGD}_{\text{PU}})_{\text{H}}} = \frac{\left(\frac{\dot{Q}_{\text{alv}}}{\text{SA}_{\text{PU}}}\right)_{\text{A}} (\dot{Q}_{\text{T}}\text{H}_{\text{b/g}})_{\text{A}}}{\left(\frac{\dot{Q}_{\text{alv}}}{\text{SA}_{\text{PU}}}\right)_{\text{H}} (\dot{Q}_{\text{T}}\text{H}_{\text{b/g}})_{\text{H}}} . \quad (\text{I-96})$$

I.3.6 Model for Category 2 Gases: Total Respiratory Tract

In the event that remote (extrarespiratory) toxicity is associated with a gas in Category 2, the dose to the respiratory tract, and therefore to the blood, is necessary to establish the dose ratio. However, in this case, the surface area of the respiratory tract is irrelevant, only the overall absorption rate in mass/time (RGD_{RT}) is important which is given by

$$\text{RGD}_{\text{RT}} = \dot{V}_{\text{E}}(C_{\text{i}} - \text{CX}(\text{EXH})_{\text{ET}}) = \dot{V}_{\text{E}}C_{\text{i}}\left(1 - \frac{C_{\text{b/a}}}{C_{\text{i}}}\right) , \quad (\text{I-97})$$

such that the dose ratio (assuming the same inspiratory concentration) is

$$\frac{(\text{RGD}_{\text{RT}})_{\text{A}}}{(\text{RGD}_{\text{RT}})_{\text{H}}} = \frac{(\dot{V}_{\text{E}})_{\text{A}}}{(\dot{V}_{\text{E}})_{\text{H}}} \frac{\left(1 - \frac{C_{\text{b/a}}}{C_{\text{i}}}\right)_{\text{A}}}{\left(1 - \frac{C_{\text{b/a}}}{C_{\text{i}}}\right)_{\text{H}}} , \quad (\text{I-98})$$

to be evaluated for each of the cases described in Section I.3.4. In the case where systemic elimination determines the blood term, the regional gas dose ratio for remote (extrarespiratory) effects of Category 2 gases is given by where E_{MAX} is equal to $0.25 \dot{Q}_{\text{T}}$.

In the case where respiratory tract metabolism and systemic elimination are equally important, the regional gas dose ratio for remote (extrarespiratory) effects of Category 2 gases is given by

$$\text{RGDR}_{\text{ER}} = \frac{(\text{RGD}_{\text{RT}})_{\text{A}}}{(\text{RGD}_{\text{RT}})_{\text{H}}} = \frac{(\dot{V}_{\text{E}})_{\text{A}}}{(\dot{V}_{\text{E}})_{\text{H}}} \frac{(0.25 \dot{Q}_{\text{T}} \text{H}_{\text{b/g}})_{\text{A}}}{(0.25 \dot{Q}_{\text{T}} \text{H}_{\text{b/g}})_{\text{H}}}, \quad (\text{I-99})$$

$$\text{RGDR}_{\text{ER}} = \frac{(\text{RGD}_{\text{RT}})_{\text{A}}}{(\text{RGD}_{\text{RT}})_{\text{H}}} = \frac{(\dot{V}_{\text{E}})_{\text{A}}}{(\dot{V}_{\text{E}})_{\text{H}}} \frac{(0.5 \dot{Q}_{\text{T}} \text{H}_{\text{b/g}})_{\text{A}}}{(0.5 \dot{Q}_{\text{T}} \text{H}_{\text{b/g}})_{\text{H}}}, \quad (\text{I-100})$$

where E_{MAX} is equal to $0.25 \dot{Q}_{\text{T}}$. Because the constants are equal in the numerator and denominator, Equations I-99 and I-100 reduce to the same equation:

$$\text{RGDR}_{\text{ER}} = \frac{(\text{RGD}_{\text{RT}})_{\text{A}}}{(\text{RGD}_{\text{RT}})_{\text{H}}} = \frac{(\dot{V}_{\text{E}})_{\text{A}}}{(\dot{V}_{\text{E}})_{\text{H}}} \frac{(\dot{Q}_{\text{T}} \text{H}_{\text{b/g}})_{\text{A}}}{(\dot{Q}_{\text{T}} \text{H}_{\text{b/g}})_{\text{H}}}. \quad (\text{I-101})$$

APPENDIX J. DERIVATION OF AN APPROACH TO DETERMINE HUMAN EQUIVALENT CONCENTRATIONS FOR EXTRARESPIRATORY EFFECTS OF CATEGORY 3 GAS EXPOSURES BASED ON A PHYSIOLOGICALLY BASED PHARMACOKINETIC MODEL USING SELECTED PARAMETER VALUES

This appendix describes in detail the derivation of the procedure used in Chapter 4 to estimate no-observed-adverse-effect level human equivalent concentrations ($\text{NOAEL}_{[\text{HEC}]}$ s) for extrarepiratory effects of gases (or vapors) in Category 3. The derivation is mathematical in nature in that the equations of state that describe the disposition of inhaled compounds in a generalized physiologically based pharmacokinetic (PBPK) model are manipulated so as to obtain a conservative estimate (with respect to the model assumptions) of $\text{NOAEL}_{[\text{HEC}]}$ s as a function of the average animal exposure concentrations ($\text{NOAEL}_{[\text{ADJ}]}$). A PBPK model is used because of the success of this type of model. For example, PBPK models that describe the body as five compartments (gas exchange and the fat, poorly perfused, richly perfused, and liver/metabolizing tissue groups) have been applied successfully to estimating the internal concentrations of chemicals (e.g., styrene, methanol, and ethylene dichloride) for the purpose of risk assessment. Although PBPK modeling is the choice procedure in risk assessment for dose extrapolation, this approach is not possible without the values of physiological and biochemical parameters used in the modeling process, nor without a thorough understanding of the agent's mechanism of action. These data generally are not available for most compounds.

The proposed method is based on a PBPK model in which all of any number of compartments are in parallel and in which for any compartment there can be any number of paths of removal by linear and saturable processes. Selected relevant parameter values are replaced by qualitative assumptions about species similarity and the response of internal concentrations to exposure scenarios. In order to obtain a $\text{NOAEL}_{[\text{HEC}]}$, the assumption is made that the effective dose for dose-response purposes is the arterial blood concentration of

the gas or its concentration multiplied by time ($C \times T$). (These assumptions are specified in detail in the METHODS section.) This latter assumption is consistent with our current understanding of systemic toxicity for a majority of chemicals, because the toxicity of most environmental chemicals is more directly related to the concentration of the parent compound at the target site over a period of time than to the exposure concentration over an equivalent time period.

In addition to deriving conservative $\text{NOAEL}_{[\text{HEC}]}$ estimates based on arterial blood concentrations, the method also predicts that the average blood concentration of an inhaled compound in any human tissue compartment does not exceed the average blood concentration in the corresponding animal compartment.

J.1 METHODS

J.1.1 Assumption Imposed by the Inhalation Reference Concentration Methodology

Assumption I. Noncancer toxic effects observed in chronic animal bioassays are the basis for the determination of NOAELs and the operational derivation of inhalation reference concentrations (RfCs) for human exposures, as described in Chapter 4. The animal exposure scenario is experiment-dependent and usually intermittent (e.g., 6 h/day, 5 days/week for many weeks) and is assumed periodic. Human exposure concentration is continuous and constant for 70 years. The "lifetime" chronic animal exposure scenario is equivalent to the human chronic exposure scenario for the purpose of extrapolating the NOAEL.

J.1.2 Additional Assumptions for the Proposed Method

Assumption II. All the concentrations of the inhaled gas within the animal's body are periodic with respect to time (i.e., periodic steady state—the concentration versus time profile is the same for every week). Figure 4-9 illustrates the time course to achieve periodicity for a chemical with blood:air and fat:blood partition coefficients of 1,000 and 100, respectively. Periodicity is achieved for this chemical after approximately 5 weeks. As discussed in Chapter 4 (Section 4.3.6.2), it is practical to require that these experimental periodic conditions should be met during "most" of the experiment duration in order for this model

application to result in an accurate estimate for use in the dose-response analysis. For example, if the condition is met for nine-tenths of the time (e.g., periodic during the last 90 weeks of a 100-week experiment), then estimates of average concentrations will be in error by less than 10%. Thus, the requirement for application of this model is that periodicity is achieved for 90% of the exposure period. If this is likely not to have occurred, additional uncertainty in the extrapolation is imparted and should be addressed by an uncertainty factor (Section 4.3.6.2). During most of the time humans are exposed, given Assumption I of continuous exposure, their internal concentrations are constant and in dynamic equilibrium with their exposure concentration.

Assumption III. A PBPK model describes the uptake and disposition of inhaled compounds in animals and humans. The model is diagramed in Figure J-1, and the equations of state are given by Equations J-1 through J-6. Table J-1 defines the variables and constants in the equations.

$$dM_p/dt = \dot{Q}_{alv} \times (CE - C_p + \dot{Q}_T \times (CV - CA) - r_p(CA) \quad (J-1)$$

$$dM_j/dt = Q_j \times (CA - C_j) - r_j(C_j); j = 1,2,3,\dots,n \quad (J-2)$$

$$r_p(CA) = \left[\sum_i VKF_{pi} \right] \times CA + \sum_i \left[VMAX_{pi} \times CA / (KM_{pi} + CA) \right] \quad (J-3a)$$

$$r_j(C_j) = \left[\sum_i VKF_{ji} \right] \times C_j + \sum_i \left[VMAX_{ji} \times C_j / (KM_{ji} + C_j) \right]; j = 1 \text{ to } n \quad (J-3b)$$

$$\dot{Q}_T \times CV = \left[\sum_j Q_j \times C_j \right] \quad (J-4)$$

$$\dot{Q}_T = \sum_j Q_j \quad (J-5)$$

$$CA = H_{b/g} \times C_p \quad (J-6)$$

The equations describe a model with the following properties: (1) in the respiratory tract compartment, the air, tissue and capillary blood concentrations are in equilibrium with

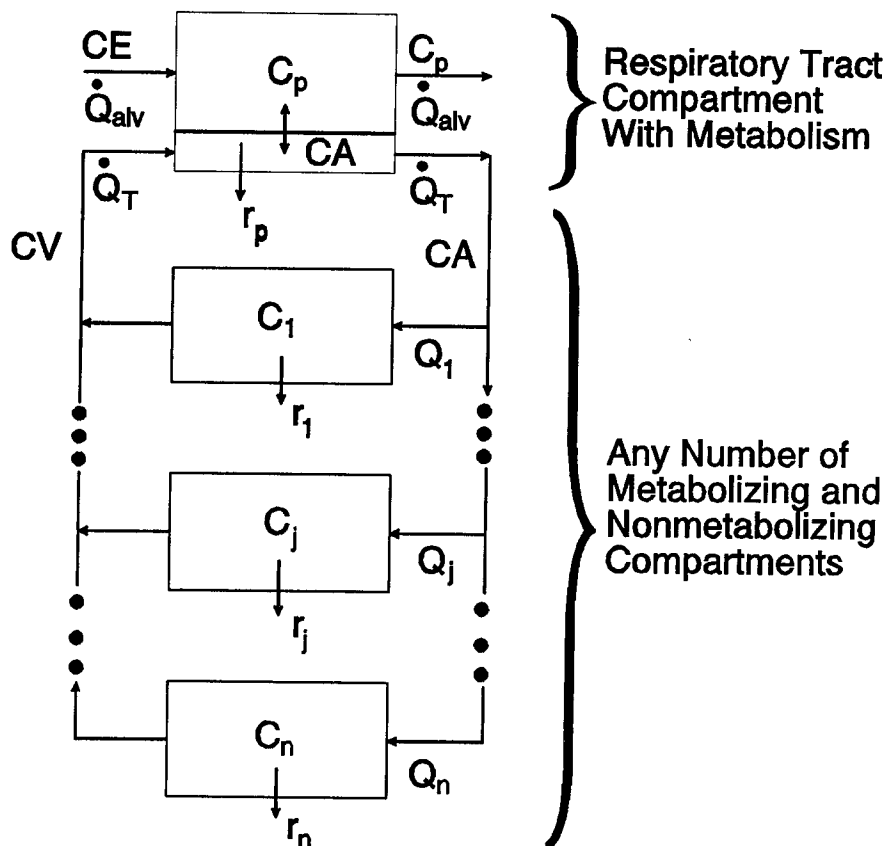

Figure J-1. Schematic of the physiologically based pharmacokinetic model assumed to describe the uptake and distribution of inhaled compounds.

respect to each other; (2) in each extrarespiratory (systemic) compartment, the blood and tissue concentrations are in equilibrium with respect to each other; (3) the metabolism and other loss mechanisms are taken into account in the tissue of the respiratory tract compartment and in the extrarespiratory (systemic) compartments; and (4) both first-order and saturable loss rates are represented and are defined in terms of blood concentrations regardless of whether or not they occur in tissue or blood.

Equations J-1, J-2, J-4, and J-5 are the dynamical equations of state or mass-balance equations for the model. Equations J-3a and 3b define the possible loss rates in each compartment in terms of linear rates (e.g., $VKF_{ji} \times C_j$) and rates of the Michaelis-Menton type (e.g., $VMAX_{pi} \times CA/[KM_{pi} + CA]$). In each compartment, the model allows for

TABLE J-1. DEFINITION OF SYMBOLS

General

V	Compartment volume
n	The number of extrapulmonary compartments
M_p	Mass of inhaled compound in gas-exchange compartment
M	Mass in compartment other than gas exchange
×	Multiplication symbol
—	Overbar indicates average
$H_{b/g}$	Blood to air partition coefficient
P	Period of periodic exposure concentration
L	Liters
h	Hours

Subscripts

i	i-th path of loss of primary compound
p	Gas-exchange compartment
j	j-th extrapulmonary compartment
A	Animal
H	Human
HEC	Human equivalent concentration

Flow Rates (L/h)

\dot{Q}_{alv}	Alveolar ventilation
\dot{Q}_T	Cardiac output
Q	Extrapulmonary (systemic) compartment perfusion rate

Concentrations (mg/L)

C	In venous blood within and leaving extrapulmonary (systemic) compartment
CE	Exposure
C_p	In air of pulmonary region
CA	In arterial (unoxygenated) blood
CV	In venous (oxygenated) blood entering gas-exchange region

Biochemical

r	Removal rate due to metabolism, reactions, excretion, etc. (mg/h); when denoted as r(c) this indicates dependence on given concentration
VMAX	Maximum velocity of saturable (Michaelis-Menton) metabolism path (mg/h)
KM	Michaelis constant (mg/L)
KF	First-order rate constant (h^{-1})
VKF	Equals to $V \times KF$ (L/h)

more than one path of elimination or metabolism or for no losses (i.e., set both of a compartment's kinetic parameters, VKF and VMAX, to zero). Equation J-6 gives the assumed relationship between the arterial blood concentration and the concentration in the air of the pulmonary region.

According to Assumption I, the exposure concentration is periodic for laboratory animals and constant for humans; in both cases, concentration of exposure (CE) can be written as

$$CE = f(t) \times \overline{CE}, \quad (J-7)$$

where:

\overline{CE} = the average exposure concentration, and

f = a periodic function of time (t) such that

$$f(t + P) = f(t) \quad (J-8a)$$

$$\int_t^{t+P} f(t) \times dt = 1; \quad (J-8b)$$

and P is the period of the periodic exposure concentration.

Assumption IV. Because the toxicologically effective dose to a given target tissue depends on the animal species and chemical compound, its specification is typically not available so that definition of a surrogate dose must be somewhat arbitrary. However, the toxic effects of some compounds are expected to be directly related to the inhaled parent compound in the blood. Furthermore, the use of the average blood concentration is an internal dose "closer" to the target than a dose based on exposure concentration. Basing the effective dose extrapolation on another surrogate (e.g., metabolite) would require knowledge of the mechanisms of action and additional information about human and animal physiological parameters. Thus, for animal to human exposure extrapolation, the human equivalent

exposure concentration ($CE_{[HEC]}$) is defined in terms of the average arterial blood concentration of the inhaled parent compound by requiring that the human equilibrium concentration of arterial blood be less than or equal to the time-averaged arterial blood concentration of the animal; that is, $CA_H \leq \overline{CA}_A$. Note that the time average concentrations are the area under the curve over a period divided by the length (time) of a period (e.g., average concentration over 1 week). The equality condition defines the upper limit on an acceptable human arterial blood concentration; thus, for mathematical simplicity this assumption is formulated as:

$$CA_H = \overline{CA}_A. \quad (J-9)$$

Because of this requirement, CA_H is a function of \overline{CE}_A , because \overline{CA}_A depends on \overline{CE}_A .

Assumption V. Similarity of species is assumed in that KM and the ratios Q/\dot{Q}_{alv} , VKF/\dot{Q}_{alv} , and $VMAX/\dot{Q}_{alv}$ are defined as species independent for each removal process (see Table J-1 for definitions). The invariance of the first ratio is based on the assumption that the percent of blood flow to any compartment is independent of species and that cardiac output ($\dot{Q}_T = \text{sum of all } Q_j$) scales, with respect to body weight, in the same way as the ventilation rate (\dot{Q}_{alv}); (i.e., the ratio of \dot{Q}_T to \dot{Q}_{alv} is species-independent). The metabolic constants VMAX and VKF are assumed to scale in the same way as \dot{Q}_{alv} . Justification for this assumption about rates is based on the observation that for many species, rates scale in the same way with respect to body weight (e.g., in proportion to basal metabolism, body surface area, or body weight to some power) (Dedrick, 1973; Weiß, 1977; Dedrick and Bischoff, 1980; Boxenbaum, 1982; Rowland, 1985; Travis and White, 1988; Travis et al., 1990; Federal Register, 1992b). The invariance of the ratios VKF/\dot{Q}_{alv} and $VMAX/\dot{Q}_{alv}$ follows.

Most of the above assumptions are well supported by data on comparative anatomy and physiology, as detailed in the cited and other allometry references (Federal Register, 1992b). Collectively, they embody the concept of a basically similar mammalian physiological and anatomical plan that varies primarily in scale from one species to another. The most

problematic issue is the scaling of rates of individual metabolic transformation reactions as $BW^{3/4}$. Not only are there few data on such scaling, but some individual metabolic enzyme systems have been shown to vary across species (Federal Register, 1992b). However, several points should be made. First, there are data that support the proposition of $BW^{3/4}$ in specific cases (Federal Register, 1992b). For example, these same scaling assumptions have been used in successful PBPK modeling across species (Ramsey and Andersen, 1984; Andersen et al., 1987a; Ward et al., 1988; Allen and Fisher, 1993; Fisher and Allen, 1993). Second, overall metabolic rate (oxygen consumption, resting metabolic rate) clearly scales as $BW^{3/4}$. Indeed, this is the issue around which physiological allometry was developed. Scaling an individual metabolic step in this way corresponds to keeping it in proportion to general metabolism, which seems the best default (Federal Register, 1992b). Third, daily intake of natural toxins (the usual targets of toxicant-metabolizing enzymes) depend on intake of air, water, and food which all scale as $BW^{3/4}$. That is, scaling detoxification processes in proportion to their anticipated load also predicts $BW^{3/4}$. Variation around scaling as $BW^{3/4}$ does not invalidate the general scaling argument, nor does it provide evidence for any different scaling factor. Rather, the variation simply illustrates that any single conception of interspecies scaling can accommodate only the general trends, not the diversity of particular instances (Federal Register, 1992b). Clearly, as proposed in Section 3.2.2, when data or more sophisticated models are available for interspecies extrapolation, they should be used in preference to the default method presented herein.

Subject to the Assumptions, Equations J-1 to J-9 must be manipulated to determine CE_{HEC} as a function of the average animal exposure concentration, \overline{CE}_A . Because the concentrations and masses of a parent compound within a compartment are assumed to be periodic, the integral of the left-hand side (LHS) of Equations J-1 and J-2 over a time length of the period is zero; for example

$$\int_t^{t+P} (dM/dt') \times dt' = M(t + P) - M(t) = 0. \quad (J-10)$$

Also note that for equilibrium or steady state, as in the human case, the LHS of each of these equations (J-1 and J-2) is zero by definition. Performing the period average of both sides of Equations J-1 to J-6, the following are obtained:

$$0 = \dot{Q}_{\text{alv}} \times (\overline{CE} - \overline{C_p}) + \dot{Q}_T \times (\overline{CV} - \overline{CA}) - \bar{r}_p \quad (\text{J-11})$$

$$0 = Q_j \times (\overline{CA} - \overline{C_j}) - \bar{r}_j; j = 1, 2, 3, \dots, n \quad (\text{J-12})$$

$$\bar{r}_p = \left[\sum_i \text{VKF}_{pi} \right] \times \overline{CA} + \sum_i \left[\text{VMAX}_{pi} \times \left[\frac{\overline{CA}}{\text{KM}_{pi} + \overline{CA}} \right] \right] \quad (\text{J-13a})$$

$$\bar{r}_j = \left[\sum_i \text{VKF}_{ji} \right] \times \overline{C_j} + \sum_i \left[\text{VMAX}_{ji} \times \left[\frac{\overline{C_j}}{\text{KM}_{ji} + \overline{C_j}} \right] \right]; j = 1 \text{ to } n \quad (\text{J-13b})$$

$$\dot{Q}_T \times \overline{CV} = \left[\sum_j Q_j \times \overline{C_j} \right] \quad (\text{J-14})$$

$$\dot{Q}_T = \sum_j Q_j \quad (\text{J-15})$$

$$\overline{CA} = H_{b/g} \times \overline{C_p} \quad (\text{J-16})$$

The steady-state equations for humans are obtained from Equations J-1 and J-2 by setting the LHS of these equations to zero (the equilibrium or steady-state condition). The complete set of equations of state for humans can be obtained from Equations J-11 through J-16 by redefining the average concentrations or terms as equilibrium values (i.e., remove the overbars).

The above equations are simplified by combining Equations J-11 and J-16 to give

$$(\dot{Q}_{\text{alv}}/H_{b/g} + \dot{Q}_T) \times \overline{CA} = (\dot{Q}_{\text{alv}} \times \overline{CE}) + (\dot{Q}_T \times \overline{CV}) - \bar{r}_p, \quad (\text{J-17})$$

and Equation J-12 is expressed as

$$Q_j \times \overline{CA} = Q_j \times \overline{C_j} + \bar{r}_j; j = 1 \text{ to } n. \quad (\text{J-18})$$

Both sides of Equations J-17 and J-18 are divided by \dot{Q}_{alv} and Q_j , respectively, to give

$$u \times \overline{CA} = \overline{CE} + w \times \overline{CV} - \bar{r}_p/\dot{Q}_{alv}, \text{ and} \quad (\text{J-19a})$$

$$\overline{CA} = \overline{C}_j + \bar{r}_j/Q_j; j = 1 \text{ to } n, \quad (\text{J-19b})$$

where:

$$w = \dot{Q}_T/\dot{Q}_{alv}, \text{ and}$$

$$u = (H_{b/g}^{-1} + \dot{Q}_T/\dot{Q}_{alv}).$$

According to Assumption V, w is species independent. The parameter u is species-dependent (via $H_{b/g}$) and will be identified as such with subscripts A and H for laboratory animal and human, respectively. For simplicity and unless otherwise noted, averaged concentrations (indicated by overbar) will be those of animals and nonaveraged (no overbar) concentrations will be those of humans.

Applied to humans, Equations J-19a and J-19b are written as

$$u_H \times CA = CE + w \times CV - r_{pH}(CA)/\dot{Q}_{alv_H}, \text{ and}$$

$$CA = C_j + r_{jH}(C_j)/Q_{jH}; j = 1 \text{ to } n.$$

For laboratory animals, Equations J-19a and J-19b are written as

$$u_A \times \overline{CA} = \overline{CE} + w \times \overline{CV} - \bar{r}_{pA}/\dot{Q}_{alv_A}, \text{ and} \quad (\text{J-20c})$$

$$\overline{CA} = \overline{C}_j + \bar{r}_{jA}/Q_{jA}; j = 1 \text{ to } n. \quad (\text{J-20d})$$

The loss terms in Equations J-3, $r_p(CA)$ and the $r_j(C_j)$'s, are concave functions with the property that their second derivatives with respect to CA and C_j , respectively, are less than or

and also,

$$u_A - u_H = H_{b/g_A}^{-1} - H_{b/g_H}^{-1}.$$

Thus, Equation J-24 can be written as

$$(H_{b/g_A}^{-1} - H_{b/g_H}^{-1}) \times \overline{CA} \geq \overline{CE} - CE + w \times (\overline{CV} - CV), \text{ or} \quad (\text{J-26a})$$

$$CE \geq \overline{CE} + w \times (\overline{CV} - CV) + (H_{b/g_H}^{-1} - H_{b/g_A}^{-1}) \times \overline{CA}. \quad (\text{J-26b})$$

Comparing Equations J-22b and J-23b, and using J-25b one sees that the blood concentration of the inhaled compound in any human compartment is less than or equal to the average blood concentration in the corresponding animal compartment; that is

$$C_j \leq \overline{C}_j. \quad (\text{J-27})$$

Because of Assumption V, ($Q_{jA}/\dot{Q}_{TA} = Q_{jH}/\dot{Q}_{TH}$), it follows from Equation J-14 applied to both humans and animals, and from Equation J-27, that

$$CV \leq \overline{CV}. \quad (\text{J-28})$$

Thus, the term $w \times (\overline{CV} - CV) \geq 0$ can be dropped from Equation J-26b without affecting the inequality.

$$CE \geq \overline{CE} + (H_{b/g_H}^{-1} - H_{b/g_A}^{-1}) \times \overline{CA} \quad (\text{J-29})$$

Note that CE is the constant inhaled human concentration that would give rise to a human constant blood level that is no greater than \overline{CA} . If we choose the actual human exposure concentration to be less than or equal to this CE, as defined by $CA = \overline{CA}$, then the actual human arterial blood concentration will be less than or equal to \overline{CA} .

equal to zero. As a consequence, the average of each of these functions is less than or equal to the function evaluated at the average concentration. Suppressing the subscripts, this property is expressed as

$$\bar{r} \leq r(\bar{C}). \quad (\text{J-21})$$

Considering Equations J-21, J-20c, and J-20d, the following is noted:

$$u_A \times \bar{CA} \geq \bar{CE} + w \times \bar{CV} - r_{pA}(\bar{CA})/\dot{Q}_{alv_A}, \text{ and} \quad (\text{J-22a})$$

$$\bar{CA} \leq \bar{C}_j + r_{jA}(\bar{C}_j)/Q_{jA}; j = 1 \text{ to } n. \quad (\text{J-22b})$$

Using Equation J-9, Assumption IV (in the presentation notation, $CA = \bar{CA}$), Equations J-20a and J-20b for human are written in terms of the animal arterial blood concentration by replacing CA with \bar{CA} as follows:

$$u_H \times \bar{CA} = CE + w \times CV - r_{pH}(\bar{CA})/\dot{Q}_{alv_H} \quad (\text{J-23a})$$

$$\bar{CA} = C_j + r_{jH}(C_j)/Q_{jH}; j = 1 \text{ to } n. \quad (\text{J-23b})$$

Subtract the LHS and the right hand side (RHS) of Equation J-23a from the LHS and RHS of Equation J-22a, respectively, to obtain

$$(u_A - u_H) \times \bar{CA} \geq \bar{CE} - CE + (w \times \bar{CV} - w \times CV) - (r_{pA}(\bar{CA})/\dot{Q}_{alv_A} - r_{pH}(\bar{CA})/\dot{Q}_{alv_H}). \quad (\text{J-24})$$

Because of Assumption V, for any concentration value, C,

$$r_{pA}(C)/\dot{Q}_{alv_A} = r_{pH}(C)/\dot{Q}_{alv_H}, \text{ and}$$

$$r_{jA}(C)/Q_{jA} = r_{jH}(C)/Q_{jH};$$

The following two cases are now considered with respect to the partition coefficient.

$$\text{Case I: } H_{b/g_A} \geq H_{b/g_H}$$

The second term on the RHS of Equation J-29 is greater than or equal to zero; thus, the term can be dropped from the RHS without affecting the inequality. Obviously, with respect to model assumptions, a conservative human exposure concentration is \overline{CE} . Therefore, in terms of the variables in Chapter 4, an estimated conservative $\text{NOAEL}^*_{[\text{HEC}]}$ is given by

$$\text{NOAEL}^*_{[\text{HEC}]} = \overline{CE} = \text{NOAEL}^*_{[\text{ADJ}]}, \quad (\text{J-30})$$

where:

$\text{NOAEL}^*_{[\text{ADJ}]}$ = the observed NOAEL or analogous effect level concentration obtained with an alternate approach as described in Appendix A, adjusted for exposure duration (Equation 4-2).

$$\text{Case II: } H_{b/g_A} < H_{b/g_H}$$

The second term on the RHS of Equation J-29 is negative in this instance. The inhaled concentration must be greater than or equal to the exhaled concentration; this requires that $\overline{CE} \geq \overline{C_p}$ or $\overline{CA} \leq H_{b/g_A} \times \overline{CE}$. In Equation J-29, \overline{CA} can be replaced by the larger value, $H_{b/g_A} \times \overline{CE}$, and still preserve the inequality, hence

$$\overline{CE} \geq \overline{CE} + (H_{b/g_H}^{-1} - H_{b/g_A}^{-1}) \times H_{b/g_A} \times \overline{CE}, \text{ or} \quad (\text{J-31a})$$

$$\overline{CE} \geq \overline{CE} \times (H_{b/g_A}/H_{b/g_H}). \quad (\text{J-31b})$$

In this case, an estimated conservative $\text{NOAEL}^*_{[\text{HEC}]}$ is given by

$$\text{NOAEL}^*_{[\text{HEC}]} = (H_{b/g_A}/H_{b/g_H}) \times \overline{\text{CE}} = (H_{b/g_A}/H_{b/g_H}) \times \text{NOAEL}_{[\text{ADJ}]}, \quad (\text{J-32})$$

where:

$\text{NOAEL}^*_{[\text{ADJ}]}$ = the observed NOAEL or analogous effect level concentration obtained with an alternate approach as described in Appendix A, adjusted for exposure duration (Equation 4-2).

J.2 AN EXAMPLE OF THE RELATIONSHIP BETWEEN THE PROPOSED AND OTHER METHODS

A perspective on the proposed method can be attained by examination of Figures J-2 and J-3, plots of $\text{NOAEL}^*_{[\text{HEC}]}$ versus $\text{NOAEL}^*_{[\text{A}]}$ for the rat and mouse, respectively. These plots were created by choosing the equivalent exposure concentration that resulted in the human arterial blood concentration being equal to the average arterial blood concentration of the animal, using several methods, for the representative volatile organic compound dichloromethane (DCM).

In Figures J-2 and J-3, the "previous" method refers to the method of using the ratio of the ventilation rate divided by body weight in the laboratory animal to the ventilation rate divided by body weight in the human ratio for calculating $\text{NOAEL}^*_{[\text{HEC}]}$ estimates (Federal Register, 1980), with the modification that alveolar ventilation rates are used (U.S. Environmental Protection Agency, 1988a). The $\text{NOAEL}^*_{[\text{ADJ}]}$ of the laboratory animal (Equation 4-2) is multiplied by the ratio to calculate the $\text{NOAEL}^*_{[\text{HEC}]}$ estimate using this method. "Optimal" method refers to the use of a specific PBPK model with an extensive set of experimentally determined physiological parameters for the three species (Andersen et al., 1987a). The same model and human parameters were used for the "similar" method, but the animal parameters were determined by scaling from the human values, as defined in Assumption V. The "proposed" results are based on the methods proposed in this document and derived in this appendix.

In keeping with the results of the derivation that is the subject of this appendix, the "proposed" $\text{NOAEL}^*_{[\text{HEC}]}$ estimates are less than the "similar" method estimates. With

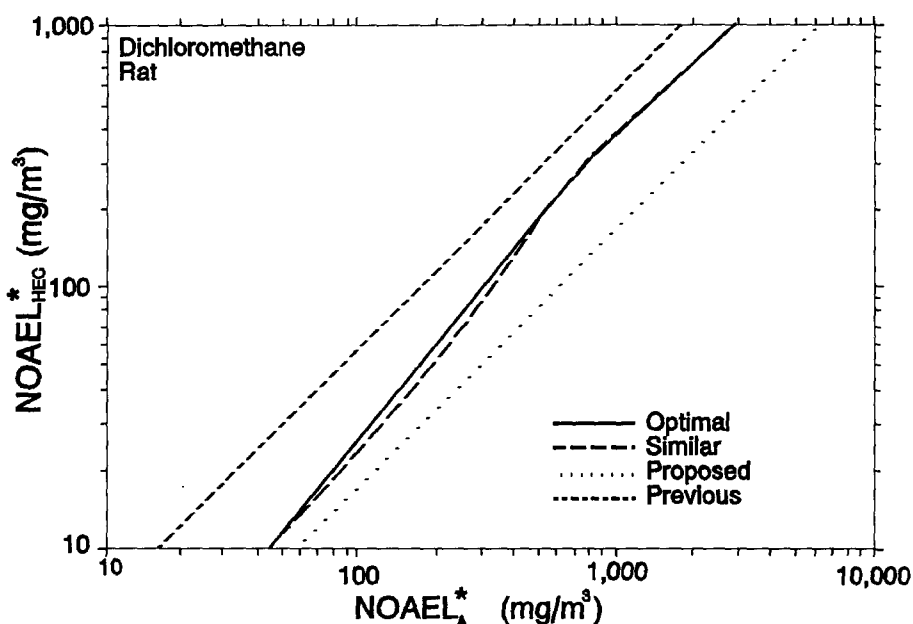

Figure J-2. Plot of $\text{NOAEL}^*_{\text{[HEC]}}$ versus $\text{NOAEL}^*_{\text{[A]}}$ for the rat for four possible methods (proposed, previous, similar, and optimal) of determining $\text{NOAEL}_{\text{[HEC]}}$ estimates as defined in the text. For any given observed $\text{NOAEL}^*_{\text{[A]}}$, the corresponding HEC estimate is found by going up to the method(s) line and over to the y axis. The inhaled compound is dichloromethane. NOTE: $\text{NOAEL}^*_{\text{[A]}} = \text{animal NOAEL}^*_{\text{[ADJ]}}$.

Source: Overton and Jarabek (1989a,b).

respect to the relationship of the proposed predictions to the other methods of calculation, the following observations are noted.

The "proposed" method lines are parallel to the "previous" lines and result in 3.4 and 6.9 times smaller, or more conservative, $\text{NOAEL}^*_{\text{[HEC]}}$ estimates than the "previous" method for the rat and mouse, respectively. The "proposed" rat $\text{NOAEL}^*_{\text{[HEC]}}$ estimates also fall below (i.e., are more conservative than) those of the "optimal" method by a range of 1.4 to 2.4. Except at high exposure concentrations (above approximately $1,600 \text{ mg/m}^3$), where the estimates are smaller by about 1.3, the "proposed" mouse $\text{NOAEL}^*_{\text{[HEC]}}$ estimates are up to 1.5 times greater than the "optimal" $\text{NOAEL}^*_{\text{[HEC]}}$ estimates. This supports current evidence that the mouse is not "similar" to humans in some cases (Reitz et al., 1988). However, for this species, the "proposed" method estimates more closely approximate the

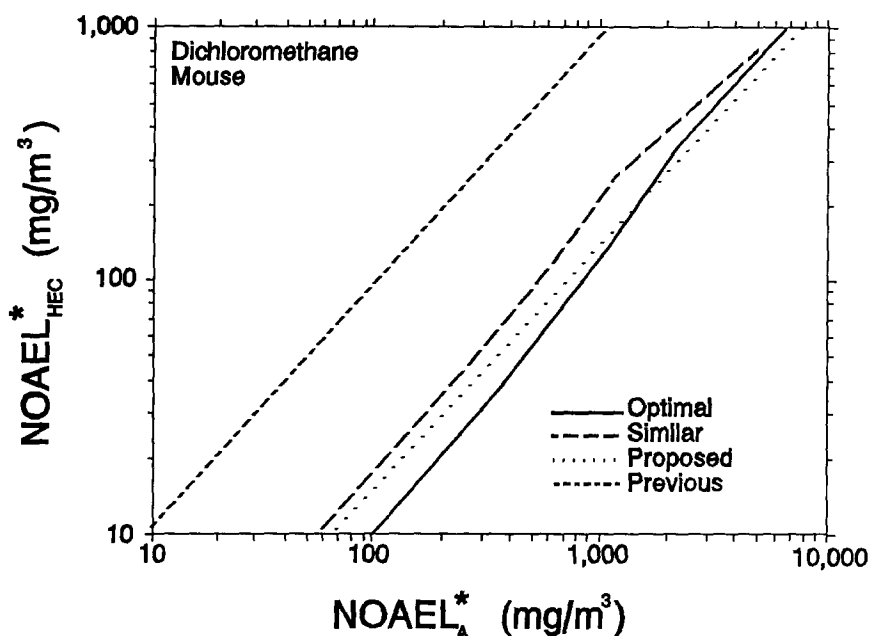

Figure J-3. Plot of $\text{NOAEL}^*_{\text{HEC}}$ versus $\text{NOAEL}^*_{\text{A}}$ for the mouse for four possible methods (proposed, previous, similar, and optimal) of determining $\text{NOAEL}^*_{\text{HEC}}$ estimates as defined in the text. For any given observed $\text{NOAEL}^*_{\text{A}}$, the corresponding HEC estimate is found by going up to the method(s) line and over to the y axis. The inhaled compound is dichloromethane. NOTE: $\text{NOAEL}^*_{\text{A}} = \text{animal NOAEL}^*_{\text{[ADJ]}}$.

Source: Overton and Jarabek (1989a,b).

"optimal" method estimates than do the "previous" estimates and the "proposed" method is conservative (estimates all fall below) the "similar" method. It also should be noted that the "optimal", "similar", and "proposed" methods result in smaller $\text{NOAEL}^*_{\text{HEC}}$ estimates for the mouse relative to the rat for the same exposure concentration, whereas the previous methodology results in the opposite relationship of estimates between the two species.

J.2.1 Discussion

Considering the "optimal" method estimates to represent the best possible dose extrapolation based on internal blood concentrations, then the "proposed" method is more realistic than the "previous" method. Because the blood:air partition coefficients are more

readily available than are complete physiological parameter data, the proposed method represents a simple default approach when extensive PBPK modeling is not feasible.

J.2.2 Research and Development

The approach presented in this appendix has resulted from modeling research focused on determining the key parameters of gas uptake, distribution, and target tissue accumulation. Future efforts will incorporate the anatomic and some aspects of the clearance data being compiled for research to support the particle model described in Appendix G. Model evaluation plans include comparing the efficiency of various dose surrogates and an approach to address the apparent nonsimilarity of the mouse. Application of the model to address mixtures of gases and of dose partitioning between gas and particles is also envisioned.