

02-1839

e.1

LA-UR-

Approved for public release;
distribution is unlimited.

Title: SOURCES 4C: A Code for Calculating (alpha,n),
Spontaneous Fission, and Delayed Neutron
Sources and Spectra

Author(s): W.B. Wilson, R.T. Perry, E.F. Shores,
W.S. Charlton, T.A. Parish, G.P. Estes,
T.H. Brown, E.D. Arthur, M. Bozoian,
T.R. England, D.G. Madland, and J.E. Stewart

Submitted to: American Nuclear Society/
Radiation Protection and Shielding Division
12th Biennial Topical Meeting
Santa Fe, NM
April 14-18, 2002



Los Alamos

NATIONAL LABORATORY

Los Alamos National Laboratory, an affirmative action/equal opportunity employer, is operated by the University of California for the U.S. Department of Energy under contract W-7405-ENG-36. By acceptance of this article, the publisher recognizes that the U.S. Government retains a nonexclusive, royalty-free license to publish or reproduce the published form of this contribution, or to allow others to do so, for U.S. Government purposes. Los Alamos National Laboratory requests that the publisher identify this article as work performed under the auspices of the U.S. Department of Energy. Los Alamos National Laboratory strongly supports academic freedom and a researcher's right to publish; as an institution, however, the Laboratory does not endorse the viewpoint of a publication or guarantee its technical correctness.

**SOURCES 4C: A Code for Calculating (α,n), Spontaneous Fission,
and Delayed Neutron Sources and Spectra**

by

W.B. Wilson,^a R.T. Perry,^a E.F. Shores,^{a,b} W.S. Charlton,^c
T.A. Parish,^d G.P. Estes,^a T.H. Brown,^a E.D. Arthur,^a M. Bozoian,
T.R. England,^a D.G. Madland,^a and J.E. Stewart^a

^a*Los Alamos National Laboratory, Los Alamos, NM 87545*

^b*University of Missouri--Rolla, MO 65401*

^c*University of Texas, Austin, TX 78712*

^d*Texas A&M University, College Station, TX 77843*

FOREWORD

This manual is a practical guide for using the Los Alamos SOURCES code. The first chapter provides an introduction and brief history of the code. The second chapter describes the theory associated with each of four problem types solved. File structure and data regarding the available isotopes are discussed in the third chapter while input and execution of the code follows in the fourth chapter. The fifth chapter describes the code's output. A variety of sample problems in the sixth chapter were designed to aid the user in constructing input files. Users may also benefit from the Los Alamos SOURCES Tape1 Creator and Library Link (LASTCALL v1.0) graphical user interface. A description of that optional application may be found in the text.

Initially conceived by W.B. Wilson and developed over collaboration with R.T. Perry and a host of others, the computer code now known as SOURCES has seen much growth since its origin more than two decades ago. Upon consideration of major improvements over the years, the user should realize the code and manual are not static entities. Indeed, this updated manual refers to the latest version of the code (4C) and reflects an upgrade in coding, data, and user friendliness of SOURCES.

The SOURCES code package, including documentation, may be obtained from the Radiation Safety Information Computational Center (RSICC), P.O. Box 2008, Oak Ridge, TN 37831-6362 USA (<http://www-rsicc.ornl.gov/rsic.html>).

E.F. Shores
505.665.7643
eshores@lanl.gov
Los Alamos, April 2002

NOTICE

This software and ancillary information (herein called SOFTWARE) called SOURCES-4C is made available under the terms described here. The SOFTWARE has been approved for release with associated LA-CC number 01-28. Unless otherwise indicated, this SOFTWARE has been authored by an employee or employees of the University of California, operator of the Los Alamos National Laboratory under Contract No. W-7405-ENG-36 with the U.S. Department of Energy. The U.S. Government has rights to use, reproduce, and distribute this SOFTWARE. The public may copy, distribute, prepare derivative works and publicly display this SOFTWARE without charge, provided that this Notice and any statement of authorship are reproduced on all copies. Neither the Government nor the University makes any warranty, express or implied, or assumes any liability or responsibility for the use of this SOFTWARE.

If SOFTWARE is modified to produce derivative works, such modified SOFTWARE should be clearly marked, so as not to confuse it with the version available from LANL.

TABLE OF CONTENTS

Foreword.....	ii
NOTICE.....	iii
Abstract.....	1
I. Introduction.....	1
A. History.....	2
B. Code Improvements.....	4
II. Theory.....	6
A. Homogeneous Mixture Problems.....	6
1. (α,n) Sources.....	6
2. Spontaneous Fission Sources.....	13
3. Delayed Neutron Sources.....	14
4. Total Neutron Source.....	14
B. Beam Problems.....	15
C. Interface Problems.....	16
D. Three-Region Interface Problems.....	19
III. File Structure and data.....	23
IV. Input and Execution.....	28
A. Homogeneous Problems (<i>idd=1</i>).....	29
B. Interface Problems (<i>idd=2</i>).....	33
C. Beam Problems (<i>idd=3</i>).....	37
D. Three Region Interface Problems (<i>idd=4</i>).....	39
E. LASTCALL.....	45
F. Execution.....	53
G. Checklist for Proper Execution.....	54
V. Description of Output.....	55
VI. Sample Problems.....	57
A. Homogeneous Mixtures.....	57
1. Sample Problem #1.....	57
2. Sample Problem #2.....	59

3. Sample Problem #3.....	60
B. Interface Problem Examples	61
1. Sample Problem #4.....	61
2. Sample Problem #5.....	63
C. Beam Problem Examples	65
1. Sample Problem #6.....	65
2. Sample Problem #7.....	67
VII. Acknowledgments.....	69
VIII. References.....	70
Appendix A.....	73
Appendix B.....	107
Appendix C.....	119
Appendix D.....	127

SOURCES 4C: A Code for Calculating (α ,n), Spontaneous Fission, and Delayed Neutron Sources and Spectra

by

W.B. Wilson, R.T. Perry, E.F. Shores, W.S. Charlton,
T.A. Parish, G.P. Estes, T.H. Brown, E.D. Arthur, M. Bozoian,
T.R. England, D.G. Madland, and J.E. Stewart

ABSTRACT

SOURCES 4C is a computer code that determines neutron production rates and spectra from (α ,n) reactions, spontaneous fission, and delayed neutron emission due to radionuclide decay. The code is capable of calculating (α ,n) source rates and spectra in four types of problems: homogeneous media (i.e., an intimate mixture of α -emitting source material and low-Z target material), two-region interface problems (i.e., a slab of α -emitting source material in contact with a slab of low-Z target material), three-region interface problems (i.e., a thin slab of low-Z target material sandwiched between α -emitting source material and low-Z target material), and (α ,n) reactions induced by a monoenergetic beam of α -particles incident on a slab of target material. Spontaneous fission spectra are calculated with evaluated half-life, spontaneous fission branching, and Watt spectrum parameters for 44 actinides. The (α ,n) spectra are calculated using an assumed isotropic angular distribution in the center-of-mass system with a library of 107 nuclide decay α -particle spectra, 24 sets of measured and/or evaluated (α ,n) cross sections and product nuclide level branching fractions, and functional α -particle stopping cross sections for $Z < 106$. The delayed neutron spectra are taken from an evaluated library of 105 precursors. The code provides the magnitude and spectra, if desired, of the resultant neutron source in addition to an analysis of the contributions by each nuclide in the problem. LASTCALL, a graphical user interface, is included in the code package.

I. INTRODUCTION

In many systems, it is imperative to have accurate knowledge of all significant sources of neutrons due to the decay of radionuclides. These sources may include neutrons resulting from the spontaneous fission of actinides, the interaction of actinide decay α -particles in (α ,n) reactions with low- or medium-Z nuclides, and/or delayed neutrons from the fission products of actinides. Numerous systems exist in which these

neutron sources could be important. These include, but are certainly not limited to, clean and spent nuclear fuel (e.g. UO_2 , ThO_2 , MOX, etc.), enrichment plant operations (e.g. those containing UF_6 or PuF_4), waste tank studies, waste products in borosilicate glass or glass-ceramic mixtures, and weapons-grade plutonium storage scenarios. The SOURCES 4C code was designed to calculate neutron sources (magnitude and spectra) resulting from any of the aforementioned interactions and decay modes.

The spontaneous fission spectra are calculated with evaluated half-life, spontaneous fission branching, and ν data using Watt spectrum parameters for 44 actinides. The (α, n) spectra are calculated with a library of 107 nuclide decay α -particle spectra, 24 sets of evaluated (α, n) cross sections and product nuclide level branching fractions, and 105 functional α stopping cross sections using an assumed isotropic neutron angular distribution in the center-of-mass system. The maximum α -particle energy of 6.5 MeV is currently imposed by SOURCES 4C due to cross section library limitations. The delayed neutron sources are calculated from a library of evaluated delayed neutron branching fractions and half-lives for 105 precursors.

The SOURCES 4C code is capable of calculating neutron sources for homogeneous, interface, monoenergetic α -beam, and three-region interface (TRI) type problems. Homogeneous problems consist of α -emitting and low-Z material mixtures and typical examples include "PuBe" neutron sources and actinide solutions. Interface problems imply a composite material consisting of two separate slab regions (source and target) such as a plated actinide or storage device. Similarly, the three-region interface problems assume a thin slab of low-Z target material sandwiched between α -emitting source material and low-Z target material. A beam problem, of course, calculates the neutron source from a monoenergetic α -beam incident on a low-Z slab. Systems that include combinations of these problems, however, must be run separately and subsequently compiled by the user.

A. History

The SOURCES-4C code has been under development since the early 1980's with continuing improvements made in both methods and data. Effectively version 1.0, the

original version of SOURCES was actually named POFEAL and primarily used for calculating the probability of an (α, n) interaction with nuclide i by an alpha particle prior to stopping in the material (P_i OF E-ALpha).¹ Developed at LANL by the Applied Nuclear Science Group (then T-2), the code was intended to calculate neutron production in source materials such as oxide and carbide fuels, plutonium metal, aqueous process solutions, and uranium enrichment processes. The Safeguards Technology Group (then Q-1) furthered interest and POFEAL's capabilities were improved by including spectral calculations and making adjustments to the calculational algorithms.² It was during this time in 1982 when the code was actually referred to as SOURCES and distinguished from POFEAL. Although often assumed an acronym, SOURCES was simply a name for the code given by W.B. Wilson, the primary developer. In addition to the original probability calculations, SOURCES (effectively version 2.0) was then able to calculate neutron "sources" from the spontaneous fission of actinide nuclides, the (α, n) reactions of their decay alpha particles with light nuclides, and delayed neutrons.

Public release via the Radiation Safety Information Computational Center (RSICC) required both a "frozen" version of the code for control purposes and a method to track changes. Consequently, a naming convention was chosen in 1997 when the two-region interface problem was added. In place for version 3A, the new convention designated a trailing numeral to indicate a major code release followed by a letter to designate any minor improvements. Thus version 3A was the third major version of the code. The capability to calculate (α, n) source rates and spectra for three-region interface (TRI) problems was added for version 4A during 1999. Minor data improvements to the tape5 library upgraded version 4A to 4B in 2001. Graduate work at the University of Missouri-Rolla provided the impetus for further enhancements and the present 4C release is an interim product for use in a SOURCES Workshop. Although a user's manual did not exist until version 3A, and versions 4A and 4C each were issued with an updated manual, minor upgrades typically would not warrant efforts to produce a revised document. The user is encouraged to monitor the code distributor's (RSICC) publications (e.g. newsletter and web-site) for updates, notices, and associated documentation related to any improvements.

Existing for both unix and DOS-based computing platforms, SOURCES-4C currently consists of a FORTRAN 77 (F77) source code, a user-created input file, up to six output files, and four library files. This manual is applicable for both types of computing platforms although installation may slightly vary on each system. Appendix C includes many works related to SOURCES not expressly referenced in this manual. These references may provide the reader with additional information regarding the historical development and theory behind the SOURCES code.

The code and manual are not static. They will continue to be improved and updated as more experimental data and computational methods become available, new features are desired, and time permits. The code continues to be available from RSICC, a computer code center authorized to collect, maintain, and distribute computer software in the areas of radiation transport and safety.

The success of SOURCES is dependent upon input from the user community. Rigorous manipulations of the code under a variety of conditions expose weaknesses that might otherwise go undetected. Any error reports or suggestions for improvement are certainly welcomed. Such contributions should be sent to the current code custodian at Los Alamos, Erik F. Shores (eshores@lanl.gov).

B. Code Improvements

While the previous major release of SOURCES, version 4A, contributed the three-region problem, the current work provides a series of improvements and corrections.

The 4C upgrade resulted in a review of the FORTRAN source code. As with any major computer code, especially one involving multiple developers over the years, mistakes or bugs regrettably find their way into the source code. Although usually minor in nature, such issues are continually sought out for correction. The following issues have been corrected and documented here to reflect the spirit of continuous improvement and our desire to produce the best version of SOURCES to date:

- The user's manual (this document) was revised (e.g. typographical errors were corrected and sections added).
- The decay data library, tape5, was updated to include spontaneous fission data for Cf-252 and revised alpha decay information for the 43 other isotopes

having Watt fission spectra parameters. See *Nuclear Instruments and Methods in Physics Research B* 179 (2001) 78-82.

- Atomic masses were updated for 105 elements to reflect the latest information in the *CRC Handbook* (81st Ed. 2000). Despite mild controversy associated with heavier element naming conventions, the IUPAC approved names for elements 104 and 105 (rutherfordium and dubnium, respectively) were altered to reflect atomic symbols Rf and Db.
- Several minor issues associated output formatting were corrected. For example, the interface calculation's *title2* card was erroneously named *title*. This label was corrected for clarity in the output. If "gas" stopping cross sections were employed (*isg* record = 1) in an interface problem, that value was omitted from the summary portion of the *outp* file (i.e. a blank space was returned instead of a "1"). This minor issue was corrected.
- M. Barnett noted an inconsistency when comparing interface and TRI problems. In version 4A's TRI problem, alpha interactions were calculated up to *eamax*—instead of the maximum alpha energy in the problem. In the likely case, however, where *eamax* exceeded the maximum alpha energy, the code stopped with an error message. To rectify this situation, the TRI problem's neutron production subroutine was modified to loop over the maximum alpha energy in the problem instead of looping over *eamax*.
- M. Barnett noted an erroneous "bc" interface value in the TRI problem. For correction, *astab(knt)* was changed to *astbc(knt)* in the *processor* subroutine.
- A bug in the TRI subroutine produced incorrect values for "sum", the variable representing an alpha's range in region B's intermediate material. Discovery of the bug was prompted by an inconsistency noted by D.E. Kornreich. An appropriate correction resulted in an upgrade to version 4C and is documented in Los Alamos National Laboratory report LA-UR-02-1617.
- The graphical user interface LASTCALL was created. See LA-UR-02-709.

II. THEORY

The SOURCES 4C code is capable of calculating neutron production rates and spectra for four different problem configurations (interface, homogeneous, beam, and three-region interface problems) with three different neutron sources: (α,n) , spontaneous fission, and delayed neutron emission. In the following section, the theory leading to each of these sources and problems is derived. Moreover, the methodology used in generating the neutron production functions is described in detail.

A. Homogeneous Mixture Problems

A homogeneous mixture problem is one in which the α -emitting material and spontaneous fission sources are intimately mixed with the low-Z target material (i.e., atoms of α -emitting material are directly adjacent to the target atoms). Three sources of neutrons exist in these problems, namely spontaneous fission neutrons, delayed neutrons, and neutrons emitted as a result of (α,n) reactions during the slowing down of α -particles. The theory pertaining to calculations for each of these neutron sources is described below. For homogeneous mixture problems, the neutron source (magnitude and spectra, if desired) is output as neutrons produced per second per unit volume. Intimate mixture and thick target conditions are assumed for all homogeneous calculations (i.e., the dimensions of the target are much smaller than the range of the α -particles) such that all α -particles are stopped within the mixture.

1. (α,n) Sources

The calculation of the (α,n) neutron production in a material requires accurate knowledge of the slowing down of the α -particles, as well as the probability of neutron production from an α -particle at energy E_α . The slowing and stopping of α -particles in a material are described by the material's stopping power,

$$SP(E) = -\frac{dE}{dx} \quad (1)$$

which yields an α -particle's energy loss per unit path length x .³ The energy loss of an α -particle of initial energy E_α in traveling a distance L can be determined from the stopping power as

$$\Delta E = E_\alpha - E'_\alpha = \int_0^L \left(-\frac{dE}{dx} \right) dx. \quad (2)$$

Similarly, the distance traveled in slowing from E_α to E'_α is

$$L = \int_{E'_\alpha}^{E_\alpha} \frac{1}{\left(\frac{dE}{dx} \right)} dE = \int_{E'_\alpha}^{E_\alpha} \frac{1}{\left(-\frac{dE}{dx} \right)} dE. \quad (3)$$

During the slowing down of the α -particles within the material, neutrons may be produced by (α, n) reactions with the nuclides contained in the material. The probability of an (α, n) interaction with nuclide i by an α -particle of energy E traveling from x to $x+dx$ is

$$N_i \sigma_i(E) dx = \frac{N_i \sigma_i(E) dE}{\left(\frac{dE}{dx} \right)} \quad (4)$$

where N_i is the atom density of nuclide i and σ_i is the microscopic (α, n) cross section for nuclide i . The probability of (α, n) interaction with nuclide i by an α -particle that slowed from E_α to E'_α is then

$$p_i(E_\alpha \rightarrow E'_\alpha) = \int_{E'_\alpha}^{E_\alpha} \frac{N_i \sigma_i(E)}{\left(\frac{dE}{dx} \right)} dE = \int_{E'_\alpha}^{E_\alpha} \frac{N_i \sigma_i(E)}{\left(-\frac{dE}{dx} \right)} dE. \quad (5)$$

Thus, the probability of an α -particle undergoing an (α, n) reaction with nuclide i before stopping in the material is given by the thick-target neutron production function,

$$P_i(E_\alpha) = \int_0^{E_\alpha} \frac{N_i \sigma_i(E)}{\left(-\frac{dE}{dx} \right)} dE. \quad (6)$$

The stopping cross section (ϵ) is defined as,

$$\epsilon(E) = -\frac{1}{N} \frac{dE}{dx} \quad (7)$$

where N is the total atom density of the material. The quantities p_i and P_i can now be expressed in terms of the stopping cross section

$$p_i(E_\alpha \rightarrow E'_\alpha) = \frac{N_i}{N} \int_{E'_\alpha}^{E_\alpha} \frac{\sigma_i(E)}{\varepsilon(E)} dE \quad (8)$$

and

$$P_i(E_\alpha) = \frac{N_i}{N} \int_0^{E_\alpha} \frac{\sigma_i(E)}{\varepsilon(E)} dE. \quad (9)$$

In general, any material involved in a homogeneous problem will be composed of any number of different elements (e.g., H, Li, Be, C, O, or Pu). The stopping cross section $\varepsilon(E)$ of a material composed of J elemental constituents may be calculated using the Bragg-Kleeman⁴ relationship

$$\varepsilon(E) \cong \frac{1}{N} \sum_{j=1}^J N_j \varepsilon_j(E) \quad (10)$$

where

$$N = \sum_{j=1}^J N_j. \quad (11)$$

A fraction of the decays of nuclide k within a material may be via α -particle emission. This fraction (F_k^α) of alpha decays may occur with the emission of one of L possible α -particle energies. The intensity f_{kl}^α is the fraction of all decays of nuclide k resulting in an α -particle of energy E_l ; and thus,

$$F_k^\alpha = \sum_{l=1}^L f_{kl}^\alpha. \quad (12)$$

Therefore, the fraction of nuclide k decays resulting in an (α, n) reaction in a thick-target material containing I nuclides with non-negligible (α, n) cross sections is

$$R_k(\alpha, n) = \sum_{l=1}^L f_{kl}^\alpha \sum_{i=1}^I P_i(E_l). \quad (13)$$

The value for $P_i(E_l)$ will be determined using the discrete form of Eq. (9),

$$P_i(E_l) = \frac{N_i}{N} \sum_{g=1}^{G-1} \frac{1}{2} \left[\frac{\sigma_i^{g+1}}{\varepsilon^{g+1}} + \frac{\sigma_i^g}{\varepsilon^g} \right] (E^{g+1} - E^g) \quad (14)$$

where $\sigma_i^1 = \sigma_i(0)$, $\sigma_i^G = \sigma_i(E_i)$, $\varepsilon^1 = \varepsilon(0)$, and $\varepsilon^G = \varepsilon(E_i)$ (i.e., the energy range has been discretized into $G-1$ energy groups). It is important to note that calculation of the (α, n) neutron source per decay of nuclide k requires an accurate knowledge of the discrete-energy (α, n) cross section for each target nuclide (σ_i^G), discrete energy stopping cross section (ε^G) for all elemental constituents, atom fraction (N_i/N) for each target nuclide, the intensity for emission of each of L α -particles (f_{kl}^α), and the energy of each of the L α -particles (E_l). Atom fractions are provided in the user-created *tape1* input file while the other quantities are available from a number of library files (see Section III).

The (α, n) spectra are determined assuming an isotropic neutron angular distribution in the center-of-mass (COM) system⁵ with a library of 89 nuclide decay α spectra and 24 sets of product-nuclide level branching fractions. Figure 1 shows an illustration of a general (α, n) reaction in the laboratory system where any associated gamma ray is assumed to be emitted after the neutron is emitted. This assumption is identical to neglecting the momentum of any associated gamma ray, but it accounts for its energy.

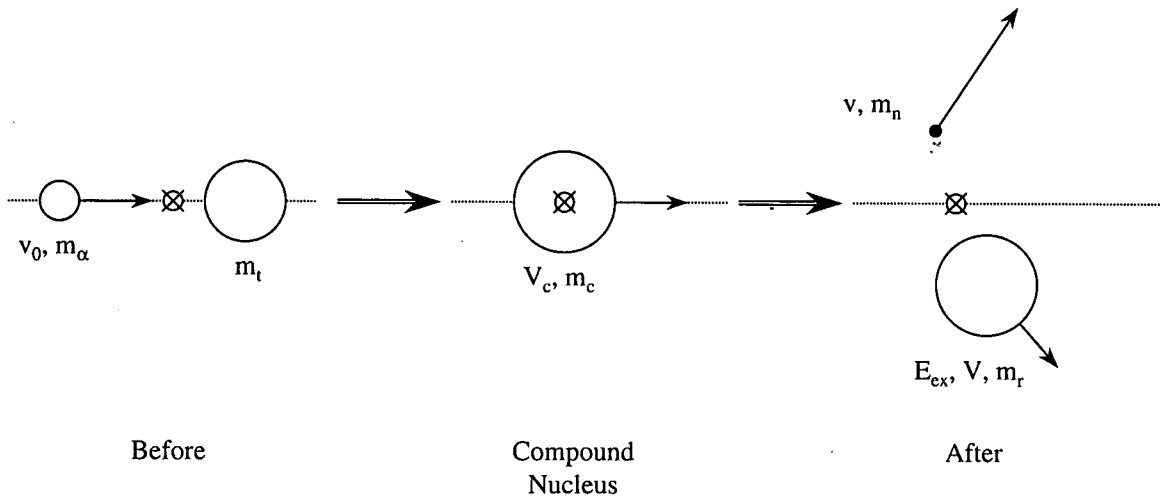

Fig. 1. (α, n) Reaction in the Laboratory System.

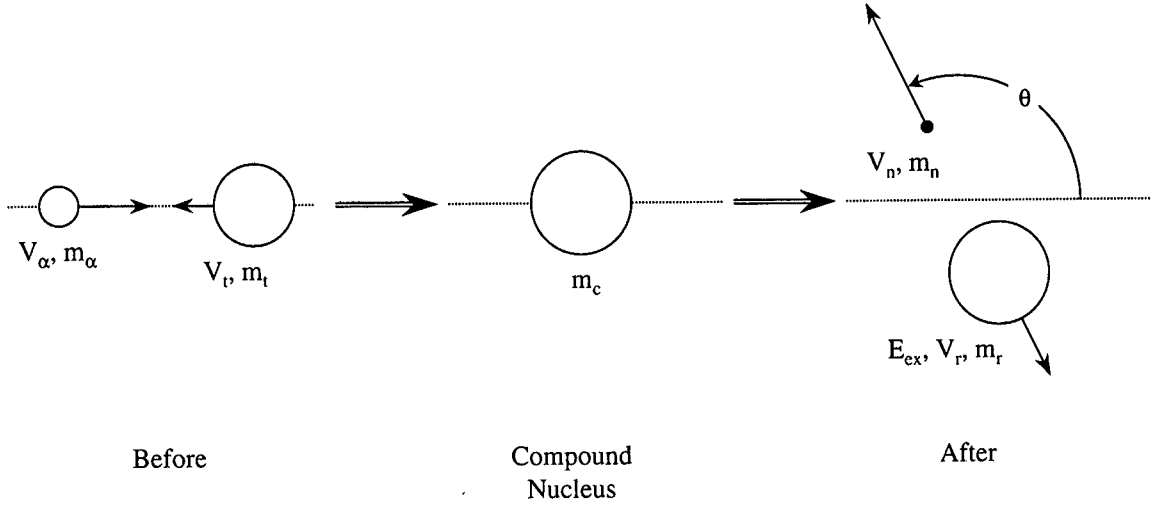

Fig. 2. (α, n) Reaction in the Center-of-Mass System.

It is readily apparent from conservation of momentum that the velocity of the center-of-mass (V_c) is simply given by

$$V_c = \left(\frac{m_\alpha}{m_\alpha + m_t} \right) v_0. \quad (15)$$

This is also equivalent to the velocity of the compound nucleus, assuming the compound nucleus is not in an excited state. Subtracting the velocity of the COM from the particle velocities displayed in Fig. 1 allows for a transformation to the COM coordinate system (Fig. 2). The α -particle velocity in the COM system is given by

$$V_\alpha = v_0 \left(\frac{m_t}{m_\alpha + m_t} \right). \quad (16)$$

The target nuclide velocity in the COM system is

$$V_t = -v_0 \left(\frac{m_\alpha}{m_\alpha + m_t} \right). \quad (17)$$

From conservation of energy in the COM system, we find

$$KE_n = (Q - E_{ex}) + KE_\alpha + KE_t - KE_r \quad (18)$$

where KE_n is the neutron kinetic energy, KE_α is the α -particle kinetic energy, KE_t is the target nucleus kinetic energy, KE_r is the recoil nucleus kinetic energy, E_{ex} is the

excitation level of the recoil nucleus, and Q is the reaction Q -value (all variables in the COM system). It is customary to define the reaction Q -value for production of product-nuclide level m as

$$Q_m = Q - E_{ex}. \quad (19)$$

From conservation of momentum in the vertical direction we see

$$V_r = \left(\frac{m_n}{m_r} \right) V_n. \quad (20)$$

Using Eq.'s (16) and (17), it can be shown that

$$KE_\alpha + KE_t = E_\alpha \left(\frac{m_t}{m_\alpha + m_t} \right) \quad (21)$$

where E_α is the α -particle kinetic energy in the laboratory system. The recoil nuclei kinetic energy is given by

$$KE_r = \frac{1}{2} m_r V_r^2 = \frac{1}{2} \frac{m_n^2}{m_r} V_n^2 = KE_n \left(\frac{m_n}{m_r} \right) \quad (22)$$

where we have made use of Eq. (20) and the definition of the neutron kinetic energy. Substituting Eq.'s (19), (21), and (22) into Eq. (18) yields

$$KE_n = Q_m + E_\alpha \left(\frac{m_t}{m_\alpha + m_t} \right) - KE_n \left(\frac{m_n}{m_r} \right). \quad (23)$$

Solving Eq. (23) for the neutron kinetic energy yields

$$KE_n = Q_m \left(\frac{m_r}{m_r + m_n} \right) + E_\alpha \left(\frac{m_t}{m_\alpha + m_t} \right) \left(\frac{m_r}{m_r + m_n} \right). \quad (24)$$

Using the definition of kinetic energy, the neutron velocity in COM system can be acquired as

$$V_n = \pm \sqrt{\frac{Q_m}{m_n} \frac{2m_r}{m_r + m_n} + \frac{2E_\alpha}{m_n} \frac{m_t}{m_t + m_\alpha} \frac{m_r}{m_r + m_n}}. \quad (25)$$

This can be converted to the neutron velocity in the laboratory system by adding the velocity of the COM

$$v = \sqrt{\frac{2E_\alpha}{m_\alpha} \left(\frac{m_\alpha}{m_\alpha + m_t} \right)} \pm \sqrt{\frac{Q_m}{m_n} \frac{2m_r}{m_r + m_n} + \frac{2E_\alpha}{m_n} \frac{m_t}{m_t + m_\alpha} \frac{m_r}{m_r + m_n}}. \quad (26)$$

Eq. (26) can be expressed easily in terms of the square root of the neutron kinetic energy as

$$\sqrt{E_{n,m}} = \pm \sqrt{\frac{1}{2} m_n v} \quad (27)$$

where $E_{n,m}$ is the neutron kinetic energy in the laboratory frame of reference from an incident α -particle of energy E_α and generating a product nuclei of level m . Thus the neutron kinetic energy is

$$E_{n,m}^\pm = \left(\sqrt{E_\alpha a_1} \left(\frac{1}{1+a_2} \right) \pm \sqrt{Q_m \frac{1}{1_r + a_3} + E_\alpha \frac{a_2}{1+a_2} \frac{1}{1+a_3}} \right)^2 \quad (28)$$

where we have defined

$$a_1 = \frac{m_n}{m_\alpha} \quad (29)$$

$$a_2 = \frac{m_t}{m_\alpha} \quad (30)$$

and

$$a_3 = \frac{m_n}{m_r}. \quad (31)$$

Equation (28) relates the maximum (+ second term) and minimum (– second term) permissible neutron kinetic energies from an incident α -particle of energy E_α generating a product nuclide with level m .

For each target nuclide and each source α -particle, the code can read the number of product-nuclide levels (M_i), the number of product level branching data points (M'_i), the (α,n) reaction Q -value (Q^i), the excitation energy of each product-nuclide level [$E_{ex}^i(m)$], and the fraction of (α,n) reactions at energy $E(m')$ resulting in the production of product level m [$f_i(m,m')$] from the library files. The neutron energy spectra will be discretized into a user-defined energy group structure. The fraction of target i product level m reactions of source k α -particles occurring in α -particle energy group g is

$$H_{i,k}^l(m) = \frac{P_i(E_{l+1}) - P_i(E_l)}{P_i(E_\alpha)}, \quad (32)$$

where $P_i(E_i)$ was defined in Eq. (14). The branching fraction of α -particles at E_α reacting with target nuclide i and producing product level m is

$$S_{i,k}(m) = f_i(m, m'-1) + (f_i(m, m') - f_i(m, m'-1)) \frac{E_\alpha - E(m'-1)}{E(m') - E(m'-1)}. \quad (33)$$

Thus, the fraction of α -particles at E_α reacting with target nuclide i and resulting in product level m reactions occurring in α -particle energy group g is simply the product of Eq.'s (32) and (33):

$$F_{i,k}^l(m) = S_{i,k}(m) H_{i,k}^l(m). \quad (34)$$

It will be assumed that the neutrons are isotropically emitted from the compound nucleus; therefore, they will contribute evenly to all groups between $E_{n,m}^+$ and $E_{n,m}^-$. The contribution per decay of source nuclide k to neutron energy group g is given by

$$\chi_k^{(\alpha,n)}(E_g) = R_k(\alpha, n) F_{i,k}^l(m) \frac{E_{g+1} - E_g}{E_{n,m}^+ - E_{n,m}^-}, \quad (35)$$

where E_{g+1} and E_g are between $E_{n,m}^+$ and $E_{n,m}^-$.

2. Spontaneous Fission Sources

The spontaneous fission of an actinide nuclide k is accompanied by the emission of an average $\nu_k(SF)$ neutrons. The fraction of nuclide k decays that are spontaneous fission events are given by the SF branching fraction

$$F_k^{SF} = \frac{\lambda_k^{SF}}{\lambda_k}. \quad (36)$$

Thus, the average number of SF neutrons emitted per decay of nuclide k (by any mode) is

$$R_k(SF) = F_k^{SF} \nu_k(SF). \quad (37)$$

Therefore, to compute the neutron production due to spontaneous fission per decay of nuclide k , the SF branching fraction and average number of neutrons per spontaneous fission must be known. These quantities are available to SOURCES from a library file named *tape5* (see Section III).

The spontaneous fission neutron spectra are approximated by a Watt's fission spectra using two evaluated parameters (a and b):

$$\chi_k^{SF}(E) = R_k(SF) e^{-E/a} \sinh \sqrt{bE}. \quad (38)$$

Evaluated parameters are provided for 44 fissioning nuclides in the *tape5* library file (see Section III below).

3. Delayed Neutron Sources

During the fissioning process, a number of products are formed including neutrons, gamma rays, beta rays, neutrinos, fission products, and an appreciable amount of energy. Some of the fission products formed as a result of fission can decay by β^- emission to a highly excited state, which can then decay by emitting a neutron. These neutrons are called "delayed neutrons" because they appear within the system with some appreciable time delay. The nuclide emitting the neutron is referred to as the "delayed neutron emitter," and the nuclide which β^- decays to the emitter is referred to as a "delayed neutron precursor." It is customary to assume that one neutron is emitted per decay and that the emitter decays almost instantaneously. Thus, the fraction of decays by nuclide k (by any mode) leading to the emission of a delayed neutron is given by the product of the DN branching fraction (F_k^{DN}):

$$R_k(DN) = F_k^{DN} . \quad (39)$$

Computing the neutron production rate due to delayed neutron emission requires knowledge of the DN branching fraction. The value for F_k^{DN} is provided to SOURCES in a library file (see Section III).

A series of evaluated delayed neutron spectra are provided in a library file for 105 precursor nuclides [$\phi_k(E)$].⁶ These evaluated spectra are provided in a discretized form. They are read directly into SOURCES and then adjusted so that the default spectra energy mesh correlates with the user-desired energy mesh. The energy spectra is then renormalized by multiplying through by the quantity $R_k(DN)$, such that

$$\chi_k^{DN}(E) = R_k(DN)\phi_k(E) . \quad (40)$$

4. Total Neutron Source

The average total number of neutrons per decay emitted due to (α,n) reactions, spontaneous fission, and delayed neutron emission is given by

$$R_k = R_k(\alpha, n) + R_k(SF) + R_k(DN) . \quad (41)$$

Therefore, the total neutron source from (α,n) reactions, spontaneous fission, and delayed neutron emission within a homogenous problem consisting of K pertinent radionuclides is

$$S = \sum_{k=1}^K \lambda_k N_k R_k \quad (42)$$

where λ_k is the decay constant for nuclide k and N_k is the atom density of nuclide k . A similar expression will be used for the source produced in interface and beam problems.

The energy-dependent neutron source spectra are calculated using the absolute (α,n), SF, and DN spectra calculated above for each nuclide k by an expression similar to that given in Eq. (42):

$$S_g = \lambda_k N_k \chi_k(E_g) \quad (43)$$

where

$$\chi_k(E_g) = \chi_k^{(\alpha,n)}(E_g) + \chi_k^{SF}(E_g) + \chi_k^{DN}(E_g). \quad (44)$$

B. Beam Problems

A beam problem is one in which a monoenergetic α -beam is incident upon a slab containing low- Z target material (Fig. 3). While the slab could also contain higher mass isotopes (even actinides), any α -emitting or spontaneous fissioning material would not be used to calculate a source. Such conditions must be modeled separately and compiled by the user. It is a necessary condition that the thickness, t , of the target material slab is significantly larger than the range of the beam's α -particles such that all α -particles come to rest within the target slab.

The neutron production rate within the slab per incident α -particle is a function of the α -particle beam energy (E_α) and the probability of an (α,n) interaction with any nuclide i within the slab by an α -particle from the beam prior to stopping in the material,

$$S = \sum_{i=1}^I P_i(E_\alpha). \quad (45)$$

The beam energy (E_α) must be supplied by the user. The thick-target neutron production function $[P_i(E_\alpha)]$ is calculated using Eq. (14) above. The neutron spectra are calculated using the same procedure as described in Section II.A.1.

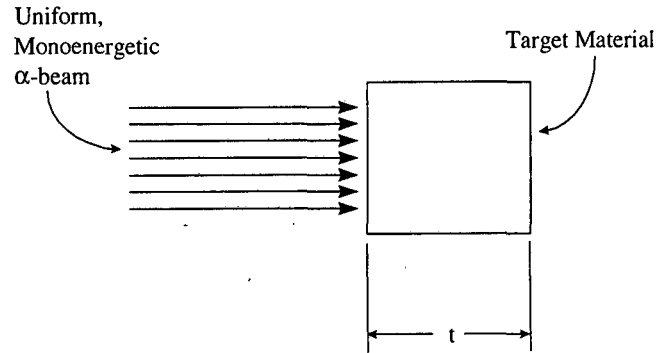

Fig. 3. General Schematic for Beam Problems.

C. Interface Problems

Interface problems (Fig. 4) exist when a slab of α -emitting material (e.g. Pu, Po, or Am) is in close contact with a low-Z target material (e.g. Be, C, or Al). In such a geometry, α -particles are emitted from the Region I materials and travel across the interface junction into the Region II materials. Once in Region II, the α -particles can interact through (α,n) reactions and generate a neutron source. It is necessary to assume in all interface problems the thickness of each region is significantly larger than the range of the α -particles within it. It is also assumed that all α -particles travel in a straight-line trajectory from their point of emission (generally an excellent assumption).

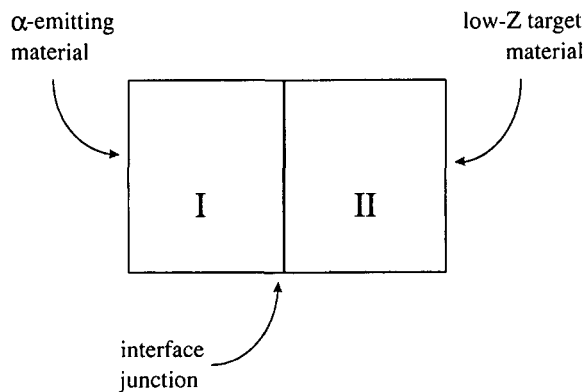

Fig. 4. General Schematic for Interface Problems.

To derive the α -particle source rate at the interface, consider the half-space above the x-y plane shown in Fig. 5. There exists a uniform volumetric source (S_v) of isotropically emitted α -particles with initial energy E_0 in this half-space. The differential area dA subtends a solid angle $d\Omega$ when viewed from the source point dV . Thus,

$$d\Omega = \frac{\cos \phi}{r^2} dA \quad (46)$$

and

$$dV = r^2 \sin \phi \cdot d\theta \cdot d\phi \cdot dr. \quad (47)$$

The rate at which α -particles are born in dV is equal to

$$S_v dV = S_v r^2 \sin \phi \cdot d\theta \cdot d\phi \cdot dr. \quad (48)$$

The solid angle subtended by dA relative to the total solid angle into which α -particles are emitted is given by

$$\frac{d\Omega}{4\pi} = \frac{\cos \phi \cdot dA}{4\pi \cdot r^2}. \quad (49)$$

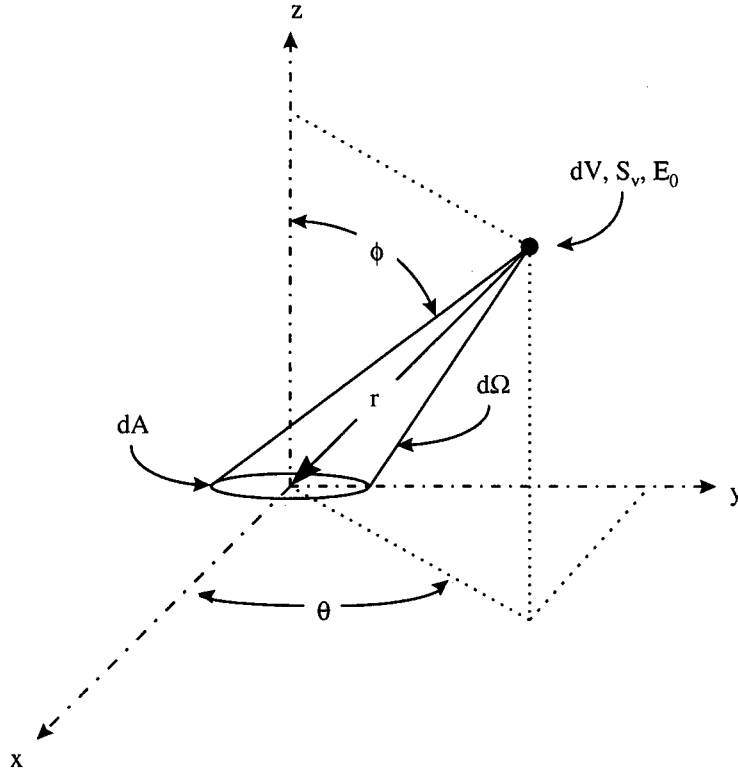

Fig. 5. The α -Particle Solid Angle to Differential Area from a Generalized α Source.

Multiplying Eq. (48) by Eq. (49) yields the number of α -particles per unit time originating within dV that can pass through dA provided that r is less than the α -particle range, or

$$dU = \frac{S_v}{4\pi} \sin \phi \cos \phi \cdot dA \cdot d\theta \cdot d\phi \cdot dr. \quad (50)$$

The rate at which α -particles pass through dA as a result of having been born in a hemispherical shell centered about dA whose radius is r and thickness is dr is acquired by integrating Eq. (50) over θ and ϕ , or

$$dU' = \frac{S_v}{4\pi} dA \cdot dr \int_0^{2\pi} d\theta \int_0^{\pi/2} \sin \phi \cos \phi \cdot d\phi. \quad (51)$$

Performing the integration yields

$$dU' = \frac{S_v}{4} dA \cdot dr. \quad (52)$$

From Eq. (7) we see

$$dr = -\frac{1}{N} \frac{dE}{\epsilon(E)} \quad (53)$$

where $\epsilon(E)$ is the stopping cross section and N is the total atom density of the material in the region. Thus, the rate at which α -particles pass through the interface per unit area is given by

$$\frac{dU'}{dA} = -\frac{S_v}{4N} \frac{1}{\epsilon(E)} dE. \quad (54)$$

Therefore, the rate at which α -particles with energies between E_g and E_{g+1} pass through the interface per unit area (Φ) is

$$\Phi^g = \frac{U}{A} = \frac{S_v}{4N} \int_{E_g}^{E_{g+1}} \frac{dE}{\epsilon(E)}. \quad (55)$$

The volumetric source (S_v) can be expressed as

$$S_v = \lambda_k N_k f_{kl}^\alpha \quad (56)$$

where λ_k is the decay constant for source nuclide k , N_k is the atom density of source nuclide k , and f_{kl}^α is the fraction of all decays of nuclide k resulting in an α -particle of energy E_{kl} . Thus we see that

$$\Phi^g = \frac{\lambda_k f_{kl}^\alpha N_k}{4 N} \int_{E_g}^{E_{g+1}} \frac{dE}{\varepsilon(E)}. \quad (57)$$

This quantity (Φ^g) is the source of α -particles between energies E_g and E_{g+1} passing into the low- Z target material of Region II per unit area and per unit time. The quantity Φ^g is then used by SOURCES as the source strength of a monoenergetic beam with energy:

$$E_{beam}^g = \frac{E_g + E_{g+1}}{2}. \quad (58)$$

SOURCES then uses the same procedure developed in Section II.B to solve for the neutron production rate due to the α -particles crossing the junction with energies between E_g and E_{g+1} . The code repeats this procedure for all α -particle energies and all source nuclides.

D. Three-Region Interface Problems

The three-region interface (TRI) arrangement consists of a middle, or intermediate region, sandwiched between a thick alpha-emitting source region and thick (α,n) target region.⁷ The source, intermediate, and target regions may be referred to as A, B, and C regions, respectively (Fig. 6). Alpha particles originating in region A may slow to interface "ab", slow through region B to interface "bc", and ultimately slow to a stop in region C. In terms of (α,n) reactions, neutrons may thus be produced in regions B or C (unless, of course, region B simply consists of slowing-down material in lieu of target material). Examples of TRI applications include exotic (α,n) sources, nuclear reactor fuel elements, holdup materials in reprocessing facilities, and storage configurations (e.g. canned material).

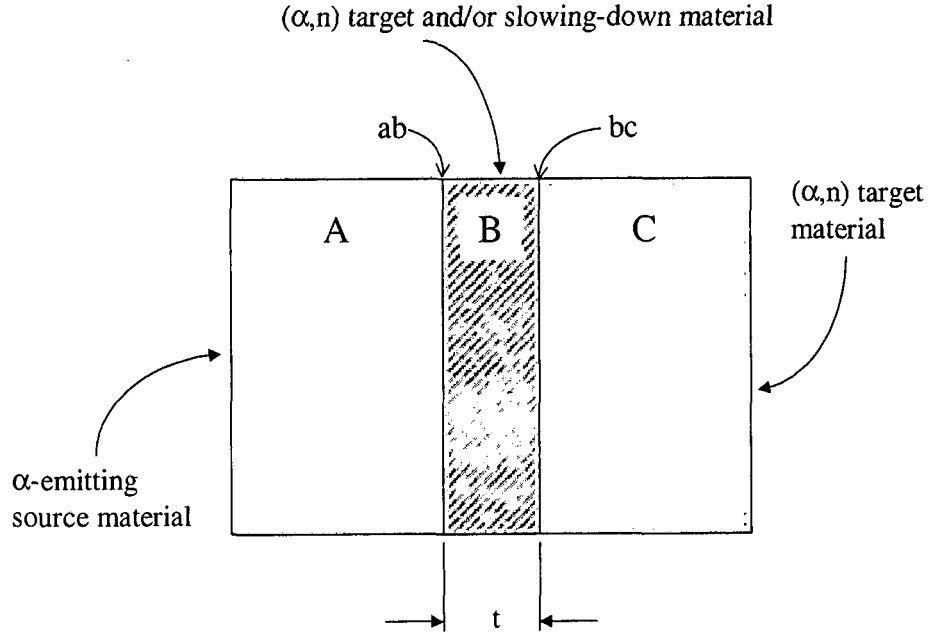

Fig. 6. General Schematic for Three-Region Interface Problem.

This problem is significantly more complicated than the two-region variety due to an inherent angular dependence of the track thickness through region B. It is necessary to assume in all interface problems the thickness of regions A and C is significantly larger than the range of the α -particles within them. Region B can have any thickness. It is also assumed that all α -particles travel in a straight-line trajectory from their point of emission (generally an excellent assumption).

The number of α -particles crossing interface ab with energies between E_g and E_{g+1} is given by:

$$\Phi_{ab}^g = \sum_{k=1}^{NN} \sum_{l=1}^{NL_k} \frac{\lambda_k f_{kl}^\alpha}{4} \left(\frac{N_k}{N} \right)_A m_{kl}^g \left(\frac{1}{\epsilon_A^g} + \frac{1}{\epsilon_A^{g+1}} \right) \left(\frac{E_{g+1} - E_g}{2} \right) \quad (59)$$

where λ_k is the decay constant of α -emitting source nuclide k, f_{kl}^α is the fraction of all nuclide k decays that result in the production of an α -particle at energy E_l^α , $(N_k/N)_A$ is the atom fraction of α -emitting source nuclide k in region A, ϵ_A^g is the stopping cross section of region A at energy E_g , and m_{kl}^g is a calculational factor given by:

$$m_{kl}^g = \begin{cases} 0 & \text{if } E_g > E_{kl}^\alpha \\ 1 & \text{if } E_{g+1} < E_{kl}^\alpha \\ \frac{E_{kl}^\alpha - E_g}{E_{g+1} - E_g} & \text{if } E_g < E_{kl}^\alpha < E_{g+1} \end{cases} \quad (60)$$

The only assumption made in equation (59) is that the function $1/\varepsilon_A^g$ is linear between E_g and E_{g+1} .

To calculate the α -particle source rate at the interface bc, we first must determine the energies at which the α -particles transition from region A to region B at an angle between ϕ_i and ϕ_{i+1} and end up at interface bc with energies between E_g and E_{g+1} . We will calculate these energies by performing the following:

$$\min_{i,trans_{i,g}} \left[\sum \left(\frac{1}{\varepsilon_B^{g'}} + \frac{1}{\varepsilon_B^{g'+1}} \right) \left(\frac{E_{g'+1} - E_{g'}}{2} \right) > \frac{t}{\cos(\phi_i)} \right] \quad \text{for all } i \text{ and } g \quad (61)$$

where $i,trans_{i,g}$ is the transition energy index and t is the thickness of the intermediate region B. The number of α -particles crossing interface bc with energies between E_g and E_{g+1} is given by:

$$\Phi_{bc}^g = \sum_{k=1}^{NN} \sum_{l=1}^{NL_k} \sum_{i=1}^I P_{g,i,k,l} \frac{\lambda_k f_{kl}^\alpha}{8} \left(\frac{N_k}{N} \right)_A (\cos(2\phi_i) - \cos(2\phi_{i+1})) m_{kl}^g \left(\frac{1}{\varepsilon_A^g} + \frac{1}{\varepsilon_A^{g+1}} \right) \left(\frac{E_{g+1} - E_g}{2} \right) \quad (62)$$

where λ_k is the decay constant of α -emitting source nuclide k , f_{kl}^α is the fraction of all nuclide k decays that result in the production of an α -particle at energy E_l^α , $(N_k/N)_A$ is the atom fraction of α -emitting source nuclide k in region A, ε_A^g is the stopping cross section of region A at energy E_g , m_{kl}^g is a calculational factor given in equation (60) above, and $P_{g,i,k,l}$ is a calculational factor given by:

$$P_{g,i,k,l} = \begin{cases} 0 & \text{if } E_{i,trans_{i,g}} > E_{kl}^\alpha \\ 1 & \text{if } E_{i,trans_{i,g}} < E_{kl}^\alpha \end{cases} \quad (63)$$

These α -particle source rates can now be used to calculate the neutron production rates in a manner not dissimilar to what was used in the interface problem of section II.C, above. To accomplish this we will calculate the neutron production rates and spectra from the α -

particle source at interface ab due to material B assuming region B is infinitely thick ($\Psi_{ab,B}^g$). We will then calculate the neutron production rates and spectra from the α -particle source at interface bc due to material B assuming region C is infinitely thick ($\Psi_{bc,B}^g$). Finally, we will calculate the neutron production rates and spectra from the α -particle source at interface bc due to material C assuming region C is infinitely thick ($\Psi_{bc,C}^g$). The total neutron production rates and spectra due to the interface is then given by:

$$\Psi^g = \Psi_{bc,C}^g + \left(\Psi_{ab,B}^g - \Psi_{bc,B}^g \right). \quad (64)$$

These multigroup neutron source rates are then output to a file for the user.

III. FILE STRUCTURE AND DATA

The SOURCES 4C code system is composed of an F77 source code, an executable, one input file, up to six output files, and four library files. All of these files (except the problem dependent SOURCES generated output files) are necessary for proper execution of the code. The name and a short description of each file included in the SOURCES 4C code system are included below:

tape1 = user-supplied input file
tape2 = stopping cross section expansion coefficients library
tape3 = target (α,n) cross section library
tape4 = target (α,n) product level branching library
tape5 = sources decay data library
tape6 = neutron source magnitudes output file
tape7 = absolute neutron spectra output file
tape8 = normalized neutron spectra output file
tape9 = neutrons spectra output file by product level
outp = summary output file
outp2 = supplemental output file organizing spectral information
SOURCE4C.for = F77 source code
SOURCE4C.exe = executable file.

Fig. 7 illustrates the sources code structure and how each file interacts with the executable file.

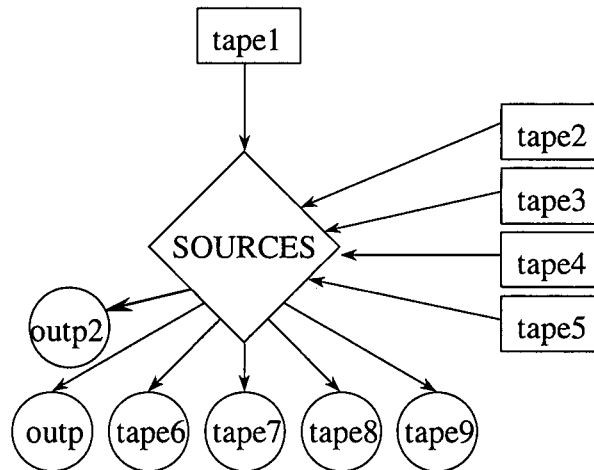

Fig. 7. Schematic Diagram of the SOURCES 4C File Structure.

The data necessary for computing the magnitude of the neutron source due to (α,n) reactions, spontaneous fission, and delayed neutron emission are:

1. The energy-dependent α -particle stopping cross section for all elemental constituents (ϵ_i^g).
2. The energy dependent (α,n) cross-section for all target nuclides (σ_i^g).
3. The intensity for emission of each of the L α -particles (f_{kl}^α).
4. The energy of each of the L α -particles (E_l).
5. The SF branching fractions for each source nuclide k (F_k^{SF}).
6. The average number of neutrons per SF of nuclide k [$\nu_k(SF)$].
7. The DN branching fraction for each nuclide k (F_k^{DN}).
8. The source nuclide decay constants (λ_k).

To calculate the neutron source spectrum, it is necessary to have data for:

1. The number of product nuclide levels (M) for all target nuclides.
2. The number of product nuclide level branching data points (M') for all target nuclides.
3. The (α,n) reaction Q-value for all target nuclides.
4. The excitation energy [$E_{ex}(m)$] of product nuclide level m for all target nuclides.
5. The fraction of (α,n) reactions with target i at energy E(m) resulting in the production of product level m.
6. The α -particle, neutron, target, and product nuclei masses.
7. Watt's fission spectrum parameters (a and b) for each source nuclide k.
8. Delayed neutron energy spectrum for each source nuclide k.

All of these parameters are included in the library files. The library files contain (α,n) target nuclide cross section parameters for the nuclei listed in Table I and source parameters for those nuclei listed in Table II. These nuclides are listed in the Z and A identification (ZAID) format defined as $ZAID = (10000Z) + (10A) + \text{state}$, where Z is the atomic number, A is the atomic mass, and the state is either 0 or 1 for ground or metastable, respectively.

TABLE I
 (α,n) Target Isotopes Available in SOURCES 4C.

Isotope	ZAID	Level Branching Fraction Data Source ^a and Energy Limit ^b (MeV)		Cross Section Data Source and Energy Limit (MeV)	
Li-7	030070	GNASH	6.5	Gibbons and Macklin ⁸	8.2
Be-9	040090	Geiger and Van der Zwan ⁹	7.9	Geiger and Van der Zwan ⁹	7.9
B-10	050100	GNASH	12	Bair <i>et al.</i> ¹⁰	7.5
B-11	050110	GNASH	12	Bair <i>et al.</i> ¹⁰	7.5
C-13	060130	GNASH	6.5	Bair and Haas ¹¹	6.5
N-14	070140	N/A ^c	-	GNASH	6.5
O-17	080170	Lesser and Schenter ¹²	6.5	Perry and Wilson ¹	10.5
O-18	080180	Lesser and Schenter ¹²	6.5	Perry and Wilson ¹	11.5
F-19	090190	Lesser and Schenter ¹²	6.0	Norman <i>et al.</i> ¹³	9.9
Ne-21	100210	N/A ^c	-	GNASH	6.5
Ne-22	100220	N/A ^c	-	GNASH	6.5
Na-23	110230	GNASH	6.5	GNASH ^a	9.9
Mg-25	120250	GNASH	6.5	GNASH	6.5
Mg-26	120260	GNASH	6.5	GNASH	6.5
Al-27	130270	GNASH	6.5	GNASH ^a	11
Si-29	140290	GNASH	6.5	GNASH ^a	6.8
Si-30	140300	GNASH	6.5	GNASH ^a	6.5
P-31	150310	GNASH	6.5	GNASH	6.5
Cl-37	170370	GNASH	6.5	Woosley <i>et al.</i> ¹⁴	9.7

a GNASH calculated and measured data (multiple data sets for some targets) are available for these nuclides in the library file. For multiple data sets, SOURCES uses the first set encountered while reading the file and by default in many cases, the GNASH calculation is used. To use an alternate data set, the user must modify the library file by reversing the order of the data sets.

b This is the highest energy limit of any data set (not necessarily the default) in the library. Consult tape3 for cross section information and tape4 for branching fraction data. Note that SOURCES is currently limited to alpha energies less than 6.5 MeV.

c Nuclide level branching data for these isotopes are absent from the library files. Thus, problems containing these isotopes can be executed only for neutron source magnitudes (*id*=1) and not for neutron source spectra (*id*=2). Sources of such data are welcomed by the author and may be submitted via electronic mail to <eshores@lanl.gov>

TABLE II
Isotopes Available as Decay Sources in SOURCES 4C.

Isotope		ZAID	Isotope		ZAID	Isotope		ZAID
1	Ce-142	581420	37	Ra-226	882260	73	Pu-243 ⁰	942430
2	Nd-144	601440	38	Ac-225	892250	74	Pu-244 ^{sf w}	942440
3	Sm-146	621460	39	Ac-226	892260	75	Am-240	952400
4	Sm-147	621470	40	Ac-227	892270	76	Am-241 ^{sf w}	952410
5	Sm-148	621480	41	Th-226	902260	77	Am-242 ⁰	952420
6	Sm-149	621490	42	Th-227	902270	78	Am-242m ^{sf w}	952421
7	Gd-152	641520	43	Th-228	902280	79	Am-243 ^{sf w}	952430
8	Pb-210	822100	44	Th-229	902290	80	Am-244 ⁰	952440
9	Bi-210	832100	45	Th-230 ^{sf w}	902300	81	Am-244m ⁰	952441
10	Bi-211	832110	46	Th-232 ^{sf w}	902320	82	Cm-240 ^{sf w}	962400
11	Bi-212	832120	47	Pa-230	912300	83	Cm-241	962410
12	Bi-213	832130	48	Pa-231 ^{sf w}	912310	84	Cm-242 ^{sf w}	962420
13	Bi-214	832140	49	U-230	922300	85	Cm-243 ^{sf w}	962430
14	Po-210	842100	50	U-231	922310	86	Cm-244 ^{sf w}	962440
15	Po-211	842110	51	U-232	922320	87	Cm-245 ^{sf w}	962450
16	Po-212	842120	52	U-233 ^{sf w}	922330	88	Cm-246 ^{sf w}	962460
17	Po-213	842130	53	U-234 ^{sf w}	922340	89	Cm-247	962470
18	Po-214	842140	54	U-235 ^{sf w}	922350	90	Cm-248 ^{sf w}	962480
19	Po-215	842150	55	U-236 ^{sf w}	922360	91	Cm-250 ^{sf w 0}	962500
20	Po-216	842160	56	U-237 ⁰	922370	92	Bk-249 ^{sf w}	972490
21	Po-218	842180	57	U-238 ^{sf w}	922380	93	Cf-248 ^{sf w}	982480
22	At-215	852150	58	U-239 ⁰	922390	94	Cf-249 ^{sf}	982490
23	At-217	852170	59	Np-235	932350	95	Cf-250 ^{sf}	982500
24	At-218	852180	60	Np-236 ⁰	932360	96	Cf-251	982510
25	At-219	852190	61	Np-236m ⁰	932361	97	Cf-252 ^{sf w}	982520
26	Rn-217	862170	62	Np-237 ^{sf w}	932370	98	Cf-253	982530
27	Rn-218	862180	63	Np-238 ⁰	932380	99	Cf-254 ^{sf}	982540
28	Rn-219	862190	64	Np-239 ⁰	932390	100	Es-253 ^{sf}	992530
29	Rn-220	862200	65	Pu-235	942350	101	Es-254 ^{sf}	992540
30	Rn-222	862220	66	Pu-236 ^{sf w}	942360	102	Es-254m ^{sf}	992541
31	Fr-221	872210	67	Pu-237	942370	103	Es-255 ^{sf}	992550
32	Fr-222	872220	68	Pu-238 ^{sf w}	942380	104	Fm-254 ^{sf}	1002540
33	Fr-223	872230	69	Pu-239 ^{sf w}	942390	105	Fm-255 ^{sf}	1002550
34	Ra-222	882220	70	Pu-240 ^{sf w}	942400	106	Fm-256 ^{sf}	1002560
35	Ra-223	882230	71	Pu-241 ^{sf w}	942410	107	Fm-257 ^{sf}	1002570
36	Ra-224	882240	72	Pu-242 ^{sf w}	942420			

⁰ Denotes 11 nuclides have zero alpha emission per Firestone and Shirley.

^{sf} Denotes 41 nuclides with nonzero spontaneous fission (SF) branching fractions.

^w Denotes 30 nuclides with nonzero SF branching fractions and parameters for Watt Fission Spectra. Note: there are 14 nuclides with Watt Fission Spectra parameters but zero SF branching fractions.

Stopping-power coefficients (a function of atomic number only) are included for all elemental constituents with $Z \leq 105$. Data by Ziegler *et al.*¹⁵ was used for all $Z \leq 92$. Stopping power coefficients calculated by Perry and Wilson¹ were used for $92 < Z \leq 105$.

Regarding the nuclides in Table II, information from the most recent edition of the *Table of Isotopes*¹⁶ was used to update the alpha spectra. In fact, the modification of *tape5* data resulted in an upgrade of SOURCES to version 4B. Additional information concerning the update may be found elsewhere.¹⁷

Although a 6.5 MeV energy limitation is imposed by SOURCES because of data restrictions, inspection of the *tape5* file indicates 21 nuclides have at least one alpha of energy greater than 6.5 MeV: Bi-211, Po-211, Po-212, Po-213, Po-214, Po-215, Po-216, At-215, At-217, At-218, Rn-217, Rn-218, Rn-219, Ra-222, Es-253, Es-254, Es-254m, Fm-254, Fm-255, Fm-256, Fm-257. Of approximately 750 total alpha lines contained in the *tape5* library, these 21 nuclides contribute 70 alpha lines above the 6.5 MeV energy limit (Fm-255 is responsible for 21) and range as high as 8.7844 MeV (Po-212).

Recognizing limitations of the library file data sets and potential for improvement, users are invited to submit new data or references from the literature. In particular, data is lacking for N-14, Ne-21, and Ne-22 such that spectral calculations cannot be made for problems containing these target materials.

IV. INPUT AND EXECUTION

The SOURCES input is designed to be relatively simple; however, its length can vary over a wide range from exceptionally short (≤ 10 lines) to relatively long (≥ 50 lines). This range is a function of the number of nuclides (source and target) contained in the problem. Appropriate knowledge of the physics (both macroscopic and microscopic) inherent to any problem is vital for proper execution of SOURCES (e.g. see the Po-Be sample problems in Section VI). All SOURCES input is free format with spaces or commas as delimiters (note that spaces may be more aesthetically pleasing). The input deck should be created in a file named *tape1* for use by the SOURCES executable. Every SOURCES problem begins with the same two cards, or input lines composed of records:

card 1: title

card 2: idd id erg

The first card is a title card with a maximum length of 77 characters. The second card contains three records (*idd*, *id*, and *erg*) defining the type of problem to be considered, the type of neutron source output, and energy structure, respectively. The record *idd* may be 1 (homogeneous problem), 2 (an interface problem), 3 (beam problem), or 4 (three-region interface problem). The record *id* may be 1 (magnitudes only) or 2 (magnitudes and spectra). New for version 4C, the *erg* record determines the histogram structure of the energy spectrum produced in the output files. An ascending spectrum is designated by a positive integer (typically 1) while a descending spectrum is designated by a negative integer (typically -1). This record may be especially useful for later manipulation of the spectra (e.g. subsequent use as input for other transport codes). The remaining input cards depend upon the type of problem being considered.

The following four sections (A-D) use eight example problems to describe the input required for each problem type. Designed to display the capabilities of SOURCES and serve as a guide to creating similar problems, portions of the outputs for six examples are presented in Appendix A. After a short discussion on execution and output of the code, Section VI presents several sample problems to further guide the user.

A. Homogeneous Problems ($idd=1$)

A homogeneous problem must contain at least 8 cards describing the elemental constituents in the material, the neutron energy group structure to be used in the output, the source nuclides present, the type of stopping cross sections to be used, and the (α, n) target nuclides present. If multiple materials are present or neutron energy spectra are requested, then more cards can exist in the input deck.

Cards 1-9 for a homogeneous problem are as follows:

<i>card 1:</i>	<i>title</i>
<i>card 2:</i>	<i>idd id erg</i>
<i>card 3:</i>	<i>nz isg</i>
<i>card 4.1 - 4.nz:</i>	<i>jzm(j) azm(j)</i>
<i>card 5:</i>	<i>nng enmax enmin (if necessary)</i>
<i>card 5.1 - 5.nng:</i>	<i>en(n) (if necessary)</i>
<i>card 6:</i>	<i>nq</i>
<i>card 7.1 - 7.nq:</i>	<i>jq(k) aq(k)</i>
<i>card 8:</i>	<i>nt nag</i>
<i>card 9.1 - 9.nt:</i>	<i>idt(i) at(i)</i>

Multiple cards are designated by subcards (i.e., if $nz=3$, then the input deck would include card 3 and subcards 4.1, 4.2, and 4.3). Each card must be entered on a new line (the exceptions are subcards 5.1 through 5.nng where all records $en(n)$ can be entered on the same line or multiple lines). Several example input decks are included below to illustrate the procedure described above. Each record is defined as follows:

<i>nz</i>	= the number of stopping cross section elemental constituents present in the material (an integer between 0 and 20).
<i>isg</i>	= the type of stopping cross sections to be used (0 for solid stopping cross sections, 1 for gas stopping cross sections).
<i>jzm(j)</i>	= the atomic number of each stopping cross section elemental constituent from $j=1$ to nz .

- azm(j) = the fraction of all atoms that are element j.
- nng = the number of neutron spectrum energy groups (integer between 1 and 750 or between -1 and -750); read only if id=2, otherwise omitted. If nng is positive, then the energy group structure will be determined by a linear interpolation between enmax and enmin (cards 5.1 through 5.nng are omitted). If nng is negative, then the energy group upper bounds must be specified on cards 5.1 through 5.nng (however, enmax and enmin must still be included).
- enmax = the maximum neutron energy in MeV (read only if id=2, otherwise omitted).
- enmin = the minimum neutron energy in MeV (read only if id=2, otherwise omitted).
- en(n) = the upper energy bound in MeV of neutron groups, listed in descending order (must contain nng records in any format); read only if id=2 and nng is negative (otherwise omitted).
- nq = the number of source nuclides to be evaluated (integer between 1 and 300).
- jq(k) = the source nuclide k identification in ZAID format (see Section III).
- aq(k) = the atom density (atoms/cm³) of source nuclide k.
- nt = the number of target nuclides (integer value between 1 and 20).
- nag = the number of α -particle energy groups to be used in calculation (integer value between 1 and 4000).
- idt(i) = the target nuclide i identification in ZAID format (see Section III).
- at(i) = the fraction of all atoms that are target nuclide i.

Three homogeneous examples are listed below. The first example demonstrates the neutron sources produced via decay in clean UO₂ fuel with 3% enriched U-235. This

problem solves for neutron source magnitudes from the homogeneous mixture. The first card is simply the title. The second card has records for $idd=1$ (homogeneous problem) and $id=1$ (neutron source magnitudes only). While $erg=1$ in this example, it is irrelevant as spectra are *not* calculated. The third card has records for $nz=2$ (two elemental constituents: uranium and oxygen) and $isg=0$ (solid stopping power coefficients). Cards 4.1 and 4.2 include the Z-values for oxygen and uranium [$jzm(1)=8$ and $jzm(2)=92$], as well as their atom fractions [$azm(1)=2/3$ and $azm(2)=1/3$]. Two source nuclides are included ($nq=2$) for U-235 and U-238 with atom densities of 6.77×10^{20} and 2.16×10^{22} atoms/cm³, respectively. Card 8 includes records for $nt=2$ and $nag=4000$. Card 9.1 and 9.2 include the atom fractions for O-17 and O-18 [the (α,n) targets in natural oxygen]. The *outp* and *tape6* files for this example are included in Appendix A.

Example Problem #1 - 3% Enriched Uranium Dioxide Fuel for Neutron Source Magnitude. See Appendix A for output.

```

Example 1 - Clean UO2 Fuel (3% enriched)
1 1 1
2 0
   8 0.6666667
   92 0.3333333
2
  922350 6.77e+20
  922380 2.16e+22
2 4000
   80170 0.000253
   80180 0.001333

```

A second example problem using the identical material characteristics used in Example Problem #1 is shown in Example Problem #2. This problem illustrates the input necessary to develop neutron spectra outputs. The value of id (the second record on card 2) has been changed to 2, and cards 5, 5.1, and 5.2 have been included to define the neutron energy spectra (these cards were absent from Example Problem #1). The spectra have been established by user input (i.e., nng is negative) to span from 0.0 to 10.0 MeV in 1.0 MeV bins. The energy group width can be of any magnitude and may vary from group to group. The *outp*, *tape7*, and *tape9* files for this example are included in Appendix A.

Example Problem #2 - 3% Enriched Uranium Dioxide Fuel for Neutron Source
Magnitude and Spectra. See Appendix A for output.

```

Example 2 - Clean UO2 Fuel (3% enriched) for Spectra
1 2 1
2 0
   8 0.6666667
  92 0.3333333
-10 10.0 0.0
   10.0 9.0 8.0 7.0 6.0
    5.0 4.0 3.0 2.0 1.0
2
  922350 6.77e+20
  922380 2.16e+22
2 4000
  80170 0.000253
  80180 0.001333

```

Example Problem #3 illustrates usage of a linearly interpolated energy structure ($nng>0$) in addition to gas stopping power coefficients ($isg=1$). In this problem, the neutron source spectra and magnitudes ($id=2$) are determined for a PuF_4 gas. This problem is reminiscent of possible criticality conditions in enrichment operations. The energy spectra have been established to include 20 groups ($nng=20$) linearly interpolated from 15.0 ($enmax$) to 0.0 ($enmin$) MeV. This problem includes five isotopes of plutonium (Pu-238, Pu-239, Pu-240, Pu-241, and Pu-242) and one isotope of americium (Am-241) as sources ($nq=6$). Also one isotope of fluorine (F-19) is included as an (α,n) target ($nt=1$). Because of its low concentration, americium was neglected as an elemental constituent. Thus, only two elemental constituents are present (Pu and F, $nz=2$) to slow the α -particles. Both elements employ gas stopping power coefficients. The number of α -particle energy groups (nag) was set at 2000.

To facilitate easier reading by the user, tape1's free-form input allows atom densities to be entered in any format (i.e., decimal notation or scientific notation with or without an exponential "+" or "-" sign). Spaces may be used freely. Also, nuclides may be included as sources or targets and not appear as an elemental constituent.

Example Problem #3 - PuF₄ Gas for Neutron Source Magnitude and Spectra.

Example 3 - PuF₄ Gaseous Problem

```
1 2 1
2 1
      9 0.8
      94 0.2
20 15.0 0.0
6
  942380 2.13e+17
  942390 2.54e+21
  942400 1.65e20
  942410 7.39e18
  942420 8.99e17
  952410 4.37e18
1 2000
  90190 0.8
```

B. Interface Problems (*idd=2*)

An interface problem input deck is divided into two sections, one for the source side and one for the target side. The deck must contain at least 13 cards to describe the material constituents of both the source and target sides, the source nuclides present, the target nuclides present, the types of stopping cross sections to be used, the α -particle energy group structure to be used at the interface, and the neutron source energy group structure to be used in the output. The cards are described below and followed by two example input decks:

<i>card 1:</i>	<i>title</i>
<i>card 2:</i>	<i>idd id erg</i>
<i>card 3:</i>	<i>nzq isgq eamax eamin</i>
<i>card 4.1 - 4.nz:</i>	<i>jzq(j) azq(j)</i>
<i>card 5:</i>	<i>naq</i>
<i>card 6:</i>	<i>nq</i>
<i>card 7.1 - 7.nq:</i>	<i>jq(k) aq(k)</i>
<i>card 8:</i>	<i>title2</i>
<i>card 9:</i>	<i>nzt isgt</i>
<i>card 10:</i>	<i>jzt(k) azt(k)</i>
<i>card 11:</i>	<i>nng enmax enmin (if necessary)</i>

card 11.1 - 11.nng: *en(n)* (if necessary)
card 12: *nt nag*.
card 13.1 - 13.nt: *idt(i) at(i)*

Multiple cards are designated by subcards (i.e., if $n_z=3$, then the input deck would include cards 3, 4.1, 4.2, and 4.3). Each subcard must be entered on a new line (the exception being cards 11.1 through 11.nng where all records $en(n)$ can be entered on the same line or multiple lines). Each record is defined as follows:

nzq = the number of stopping cross section elemental constituents present in the source material (must be an integer between 0 and 20).
isgq = the type of stopping cross sections to be used for source side (0 for solid cross sections, 1 for gas cross sections).
eamax = the maximum α -particle energy for α -particle source at the interface.
eamin = the minimum α -particle energy for α -particle source at the interface.
jzq(k) = the atomic number of each stopping cross section elemental constituent from $j=1$ to nzq for the source side.
azq(k) = the fraction of all atoms on source side that are element k .
naq = the number of α -particle energy groups (integer between 1 and 4000) for α -particle source at the interface.
nq = the number of source nuclides to be evaluated (integer value between 1 and 300).
jq(k) = the source nuclide k identification in ZAID format (see Section III).
aq(k) = the fraction of all atoms on source side that are source nuclide k .
title2 = title record for the target side (maximum of 77 characters).

- nzt = the number of stopping cross section elemental constituents present in the target material (must be an integer between 0 and 20).
- isgt = the type of stopping cross sections to be used for the target side (0 for solid cross sections, 1 for gas cross sections).
- jzt(k) = the atomic number of each stopping cross section elemental constituent from $j=1$ to nzt for the target side.
- azt(k) = the fraction of all atoms on target side that are element k.
- nng = the number of neutron spectrum energy groups (integer between 1 and 750 or between -1 and -750); read only if id=2, otherwise omitted. If nng is positive, the energy group structure will be determined by a linear interpolation between enmax and enmin (cards 5.1 through 5.nng are omitted). If nng is negative, the energy group upper bounds must be specified on cards 5.1 through 5.nng (however enmax and enmin must still be included).
- enmax = the maximum neutron energy in MeV (read only if id=2, otherwise omitted).
- enmin = the minimum neutron energy in MeV (read only if id=2, otherwise omitted).
- en(n) = the upper energy bound in MeV of neutron groups, listed in descending order (must contain nng records in any format); read only if id=2 and nng is negative (otherwise omitted).
- nt = the number of target nuclides (integer between 1 and 20).
- nag = the number of α -particle energy groups to be used in calculation (integer value between 1 and 4000).
- idt(i) = the target nuclide i identification in ZAID format (see Section III).
- at(i) = the fraction of all atoms on target side that are nuclide i.

Example Problem #4 consists of a slab of weapons grade plutonium (WPu) adjacent to a slab of Be. The problem has $idd=2$ to signify an interface problem and $id=2$ for a magnitudes and spectra solution. The WPu consists of 5 isotopes of plutonium (Pu-238, Pu-239, Pu-240, Pu-241, and Pu-242) and one isotope of americium (Am-241) as a contaminant. Thus, $nzq=2$ (for Pu and Am), and $nq=6$ (for the six isotopes of Pu and Am). Solid-stopping cross sections were used for both the source and target side ($isgq=isgt=0$). The α -particle energy structure at the interface consists of 100 groups linearly interpolated between 6.50 and 0.0000001 MeV. The target is composed of beryllium metal, thus $nzt=1$ and $nt=1$ (for Be-9 only). The neutron energy group structure is defined to contain 20 groups linearly interpolated between 10.0 and 0.0 MeV. Files outp, tape6, and tape7 for this example are included in Appendix A.

Example Problem #5 models a problem with a pure Am-241 source material interfaced with an AlB_2 plate. This example solves for the neutron source magnitudes only ($id=1$) using only Am-241 as the source material ($nzq=1$). The target material is made of Al and B ($nzt=2$). Note that the elemental constituents can be entered in any order [i.e., Al ($Z=13$) before B ($Z=5$)]; however, the target isotopes must be in increasing Z Aid order. Three (α,n) target isotopes are present: B-10, B-11, and Al-27.

Example Problem #4 - Weapons Grade Pu-Be Interface Source Calculation for Magnitudes and Spectra.

```

Example 4 - WPu-Be Interface Problem
2 2 1
2 0 6.50 0.0000001
  94 0.9998
  95 0.0002
100
6
  942380 0.0005
  942390 0.9233
  942400 0.0650
  942410 0.0100
  942420 0.0010
  952410 0.0002
target is composed of Be
1 0
  4 1.0
20 10.0 0.0
1 4000
  40090 1.0

```

Example Problem #5 - Am-AlB₂ Interface Calculation for Neutron Source Magnitudes and Spectra.

Example 5 - Am-AlB₂ Interface Problem

```
2 1 1
1 0 6.50 0.000001
  95 1.0
52
1
  952410 1.00
target is composed of AlB2
2 0
  13 0.333333
  5 0.666667
3 4000
  50100 0.132667
  50110 0.534000
  130270 0.333333
```

C. Beam Problems (*idd=3*)

The input deck for a beam problem is traditionally simpler than that of an interface or homogeneous problem as the problem is devoid of source nuclide descriptions. A beam problem must contain at least eight cards describing the elemental constituents in the material, the neutron energy group structure to be used in the output, the α -particle beam energy, the type of stopping cross sections to be used, and the (α ,n) target nuclides present. If multiple materials are present or a neutron energy spectrum is requested, then more cards can exist in the input deck. Cards 1–8 are as follows:

<i>card 1:</i>	<i>title</i>
<i>card 2:</i>	<i>idd id erg</i>
<i>card 3:</i>	<i>nz isg</i>
<i>card 4.1 - 4.nz:</i>	<i>jzm(j) azm(j)</i>
<i>card 5:</i>	<i>nng enmax enmin (if necessary)</i>
<i>card 5.1 - 5.nng:</i>	<i>en(n) (if necessary)</i>
<i>card 6:</i>	<i>ebeam</i>
<i>card 7:</i>	<i>nt nag</i>
<i>card 8.1 - 8.nt:</i>	<i>idt(i) at(i)</i>

Note that multiple cards are designated by subcards (i.e., if *nz=3*, then the input deck would include cards 3, 4.1, 4.2, and 4.3). Each subcard must be entered on a new line

(the exception being cards 5.1 through 5.nng where all records $en(n)$ can be entered on the same line or multiple lines). Each record is defined as follows:

- nz = the number of stopping cross section elemental constituents present in the material (must be an integer between 0 and 20).
- isg = the type of stopping cross sections to be used (0 for solid stopping cross sections, 1 for gas stopping cross sections).
- jzm(j) = the atomic number of each stopping cross section elemental constituent from $j = 1$ to nz.
- azm(j) = the fraction of all atoms that are element j.
- nng = the number of neutron spectrum energy groups (integer between 1 and 750 or between -1 and -750); read only if id=2, otherwise omitted. If nng is positive, then the energy group structure will be determined by a linear interpolation between enmax and enmin (cards 5.1 through 5.nng are omitted). If nng is negative, then the energy group upper bounds must be specified on cards 5.1 through 5.nng (however enmax and enmin must still be included).
- enmax = the maximum neutron energy in MeV (read only if id=2, otherwise omitted).
- enmin = the minimum neutron energy in MeV (read only if id=2, otherwise omitted).
- en(n) = the upper energy bound in MeV of neutron groups, listed in descending order (must contain nng records in any format); read only if id=2 and nng is negative (otherwise omitted).
- ebeam = the α -particle beam energy in MeV.
- nt = the number of target nuclides (integer between 1 and 20).
- nag = the number of α -particle energy groups to be used in

calculation (integer value between 1 and 4000).

idt(i) = the target nuclide i identification in ZAID format (see Section III).

at(i) = the fraction of all atoms that are target nuclide i.

Example Problem #6 illustrates the procedure described above. This beam problem (*idd=3*) consists of a slab of silicon dioxide bombarded by 5.5 MeV α -particles (*ebeam=5.5*). Solid stopping cross section values (*isg=0*) are used for the two elemental constituents (*nz=2*) present in the problem (Si and O). The problem solves for the neutron source magnitudes and spectra (*id=2*) resulting from four (*nt=4*) target isotopes (O-17, O-18, Si-29, and Si-30). Output information for this problem is presented in Section V.

Example Problem #6 - 5.5 MeV α -particle Beam Incident on a Slab of Silicon Dioxide.

```
Example 6 - Alpha Beam (5.5 MeV) on SiO2
3 2 1
2 0
      8 0.666667
      14 0.333333
-22 10.0 0.0
    10.00 7.00 6.00 5.50 5.00 4.50 4.00 3.50 3.25
     3.00 2.75 2.50 2.25 2.00 1.75 1.50 1.25 1.00
     0.75 0.50 0.25 0.10
5.5
4 4000
    80170 0.000253
    80180 0.001333
    140290 0.015567
    140300 0.010333
```

D. Three Region Interface Problems (*idd=4*)

A three-region interface (TRI) problem input deck is divided into four sections. The first section contains information regarding the energy and angular grids to be used in the calculations. The remaining three sections pertain to each of the three slab regions. The deck must contain at least 15 cards to describe the α -particle energy grid at each interface, the neutron energy grid for the output, the angular grid, material constituents

for all regions, the source nuclides present, the target nuclides present, and the types of stopping cross sections to be used. The cards are described as follows:

<i>card 1:</i>	<i>title</i>
<i>card 2:</i>	<i>idd id erg</i>
<i>card 3:</i>	<i>nag eamax eamin</i>
<i>card 4:</i>	<i>nng enmax enmin (if necessary)</i>
<i>card 4.1 - 4.nng:</i>	<i>en(n) (if necessary)</i>
<i>card 5:</i>	<i>ncg</i>
<i>card 6:</i>	<i>title1</i>
<i>card 7:</i>	<i>nza isga</i>
<i>card 8.1 - 8.nza:</i>	<i>jza(j) aza(j)</i>
<i>card 9:</i>	<i>nq</i>
<i>card 10.1 - 10.nq:</i>	<i>jq(k) aq(k)</i>
<i>card 11:</i>	<i>title2</i>
<i>card 12:</i>	<i>nzb isgb anumb t</i>
<i>card 13:</i>	<i>jzb(k) azb(k)</i>
<i>card 14:</i>	<i>ntb</i>
<i>card 15.1 - 15.ntb:</i>	<i>idb(i) atb(i)</i>
<i>card 11:</i>	<i>title3</i>
<i>card 12:</i>	<i>nzc isgc</i>
<i>card 13:</i>	<i>jzc(k) azc(k)</i>
<i>card 14:</i>	<i>ntc</i>
<i>card 15.1 - 15.ntc:</i>	<i>idc(i) atc(i)</i>

Multiple cards are designated by subcards (i.e., if *nza*=3, then the input deck would include subcards 8.1, 8.2, and 8.3). Each subcard must be entered on a new line (the exception being cards 4.1 through 4.nng where all records *en(n)* can be entered on the same line or multiple lines). Each record is defined as follows:

- nag = the number of α -particle energy groups (integer between 1 and 4000) for α -particle source at each interface.
- eamax = the maximum α -particle energy for α -particle source at each interface.
- eamin = the minimum α -particle energy for α -particle source at each interface.
- nng = the number of neutron spectrum energy groups (integer between 1 and 750 or between -1 and -750); read only if id=2, otherwise omitted. If nng is positive, then the energy group structure will be determined by a linear interpolation between enmax and enmin (cards 4.1 through 4.nng are omitted). If nng is negative, then the energy group upper bounds must be specified on cards 4.1 through 4.nng (however enmax and enmin must still be included).
- enmax = the maximum neutron energy in MeV (read only if id=2, otherwise omitted).
- enmin = the minimum neutron energy in MeV (read only if id=2, otherwise omitted).
- en(n) = the upper energy bound in MeV of neutron groups, listed in descending order (must contain nng records in any format); read only if id=2 and nng is negative (otherwise omitted).
- ncg = the number of α -particle angular groups (integer between 1 and 4000) for α -particle source at each interface.
- title1 = title record for the region A (maximum of 77 characters).
- nza = the number of stopping cross sections elemental constituents in region A (up to 20).
- jza(k) = the atomic number of each stopping cross section elemental constituent from j = 1 to nza for the region A.

aza(k) = the fraction of all atoms in region A that are element k.
 nq = the number of source nuclides to be evaluated (integer value between 1 and 300).
 jq(k) = the source nuclide k identification in ZAID format (see Section III).
 aq(k) = the fraction of all atoms in region A that are source nuclide k.
 title2 = title record for the region B (maximum of 77 characters).
 nzb = the number of stopping cross section elemental constituents present in region B (must be an integer between 0 and 20).
 isgb = the type of stopping cross sections to be used for the target side (0 for solid stopping cross sections, 1 for gas stopping cross sections).
 anumb = the atomic number density of all materials in region B (in atoms/b-cm)
 t = the thickness (in cm) of region B.
 jzb(k) = the atomic number of each stopping cross section elemental constituent from j=1 to nzb in region B.
 azb(k) = the fraction of all atoms in region B that are element k.
 ntb = the number of target nuclides (integer value between 1 and 20).
 idb(i) = the target nuclide i identification in ZAID format (see Section III) for targets in region B.
 atb(i) = the fraction of all atoms in region B that are nuclide i.
 title3 = title record for the region C (maximum of 77 characters).
 nzc = the number of stopping cross section elemental constituents present in region C (must be an integer between 0 and 20).
 isgc = the type of stopping cross sections to be used for the

target side (0 for solid stopping cross sections, 1 for gas stopping cross sections).

$jzc(k)$ = the atomic number of each stopping cross section elemental constituent from $j=1$ to nzc in region C.

$azc(k)$ = the fraction of all atoms in region C that are element k.

ntc = the number of target nuclides (integer value between 1 and 20).

$idc(i)$ = the target nuclide i identification in ZAID format (see Section III) for targets in region C.

$atc(i)$ = the fraction of all atoms in region C that are nuclide i.

Two TRI problem input decks are listed below. These fictitious examples illustrate the proper usage of the cards and records described above.

Example problem #7 consists of a slab of weapons grade plutonium (WPu) adjacent to a slab of beryllium with a thin layer of aluminum for region B. The problem has $idd=4$ to signify a TRI problem, $id=2$ for a magnitudes and spectra solution, and $erg=6$ for an ascending spectral output. The WPu material consists of five isotopes of plutonium (Pu-238, Pu-239, Pu-240, Pu-241, and Pu-242) and one americium isotope (Am-241) as a contaminant. Thus, $nzq=2$ (for Pu and Am), and $nq=6$ (for the six isotopes of Pu and Am). Solid-stopping cross sections were used for all regions ($isga=isgb=isgc=0$). The α -particle energy structure at each interface consists of 400 groups linearly interpolated between 6.50 and 0.0000001 MeV. Region B is composed of aluminum metal [$nzb=1$ and $ntb=1$ (for Al-27 only)] with a density of 0.15 atoms/b-cm and a thickness of 0.001 cm. Region C is composed of beryllium metal, thus $nzc=1$ and $ntc=1$ (for Be-9 only). The neutron energy group structure is defined to contain 20 groups linearly interpolated between 10.0 and 0.0 MeV. Forty angular groups are used at each interface ($ncg=40$).

Example Problem #7 - Weapons Grade Pu-Al-Be Interface Source Calculation for Magnitudes and Spectra.

```
Example #7 (WPu-Al-Be)
4 2 6
400 6.5 0.0000001
20 10.0 0.0
40
WPu region
2 0
  94 0.9998
  95 0.0002
6
  942380 0.0005
  942390 0.9233
  942400 0.0650
  942410 0.0100
  942420 0.0010
  952410 0.0002
Al interface
1 0 0.15 0.001
  13 1.0
1
  130270 1.0
Be reflector
1 0
  4 1.0
1
  40090 1.0
```

Example Problem #8 models a problem consisting of a small (3.0 cm) CO₂ gap located between a slab of pure Am-241 source material and an AlB₂ plate. This example solves for the neutron source magnitude and spectra (*id=2*) using only Am-241 as the source material (*nza=1*). The spectra will be presented in ascending format since the *erg* record is positive (1). Region B consists of two elements (*nzb=2*) and three (α,n) target nuclides (*ntb=3*). Gas stopping powers are used in region B (*isgb=1*). The target material in region C is made of Al and B (*nzc=2*). Note the elemental constituents can be entered in any order [i.e., Al (Z=13) may be entered before B (Z=5)]; however, the target isotopes must be ordered by increasing ZAID. For example, the three (α,n) target isotopes present in region C must be ordered as follows: B-10, B-11, and finally Al-27.

The *outp* and *tape7* output files for each of these two examples are presented in Appendix A.

Example Problem #8 - Am-CO₂-AlB₂ Interface Calculation for Neutron Source Magnitudes and Spectra.

Example 8 - Am-CO₂-AlB₂ Interface Problem

```
4 2 1
400 6.5 0.0000001
20 10.0 0.0
60
Pure Am-241 in region A
1 0
  95 1.0
1
  952410 1.0
CO2 gas in region B
2 1 0.004 3.0
  6 0.333
  8 0.667
3
  60130 0.0073333
  80170 0.0002667
  80180 0.0013333
AlB2 shield in region C
2 0
  13 0.33333
  5 0.66667
3
  50100 0.132667
  50110 0.534000
  130270 0.333333
```

E. LASTCALL

In an effort to streamline the process of creating the *tape1* file, the Los Alamos SOURCES Tape1 Creator and Library Link (LASTCALL) program was developed. Intended to supplement this manual and make the calculation process simpler, LASTCALL was designed to minimize common errors and guide the novice or typical user during *tape1* creation.

Written in Fortran using Compaq Visual Fortran, LASTCALL is an optional application consisting of a simple dialog window launched from an executable. The default view is shown in Figure 8. The executable (*lastcall.exe*), when placed in the SOURCES directory containing that code's executable and library files, will generate an input file allowing SOURCES to run (within LASTCALL, if desired) and produce typical output files.

Like the aforementioned example problems, LASTCALL is available as an instructive device for the user. A homogenous mixture problem consisting of plutonium and beryllium will be discussed later in Section VI's sample problem #1. In the interim, however, this sample problem is used to demonstrate the use of LASTCALL.

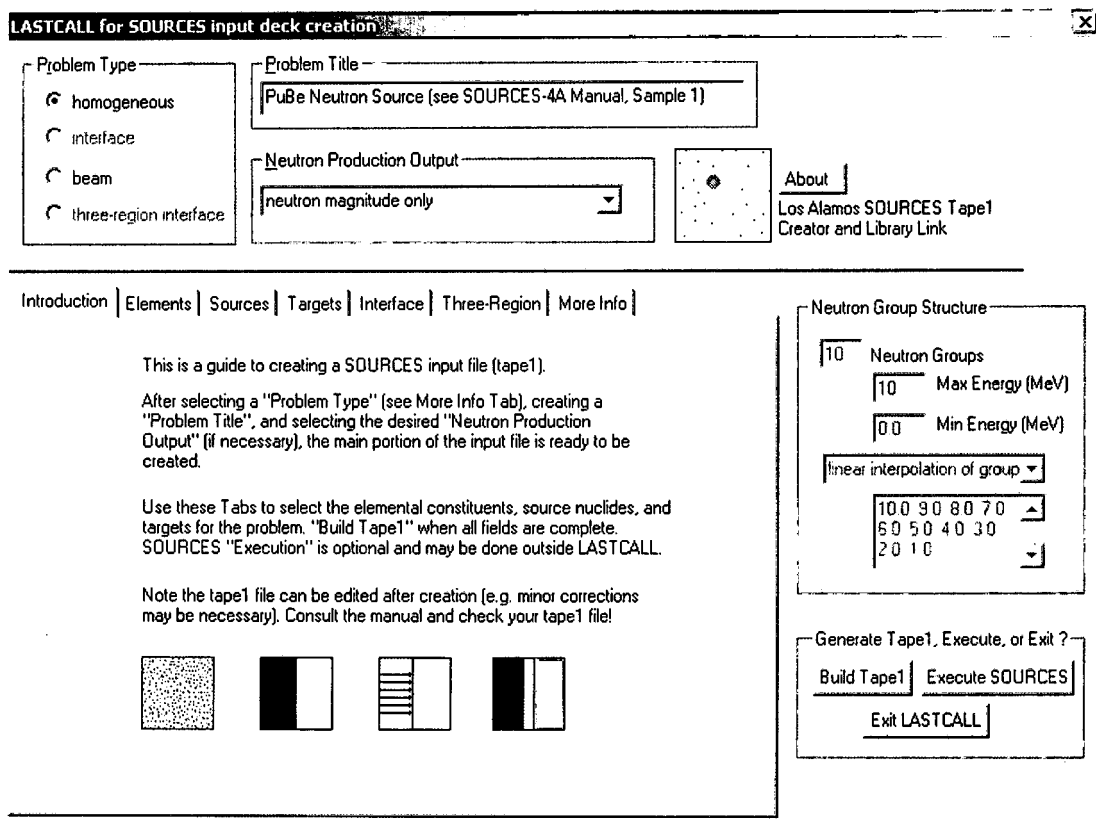

Fig. 8. The default LASTCALL display upon execution.

Referring again to Figure 8, we note the window is roughly divided into seven sections. The first section, “Problem Type” is self-explanatory and defaults to a homogenous problem. Presently, the capabilities for interface and three-region problems are unavailable and will be added as time permits. The second section, “Problem Title” is also self-explanatory. This field, limited to 77 characters, is the only comment allowed on the *tape1* file. In this case, we’ve noted our problem is a “PuBe Neutron Source...” In the third section, a selection must be made regarding “Neutron Production Output”. Options are available through a pull-down menu (Figure 9) for calculating neutron magnitudes only, or as a supplement to neutron spectra. The latter has two selections such that spectral energy bins may be presented in either ascending or descending order. The “About” button represents the optional fourth section and simply presents the name and version of the code in addition to making a solicitation for comments and suggestions regarding SOURCES or LASTCALL.

Once this preliminary information has been considered, the remaining options may be examined. The fifth section of the dialog box is a tab control subdivided into seven areas allowing description of the main portion of *tape1*.

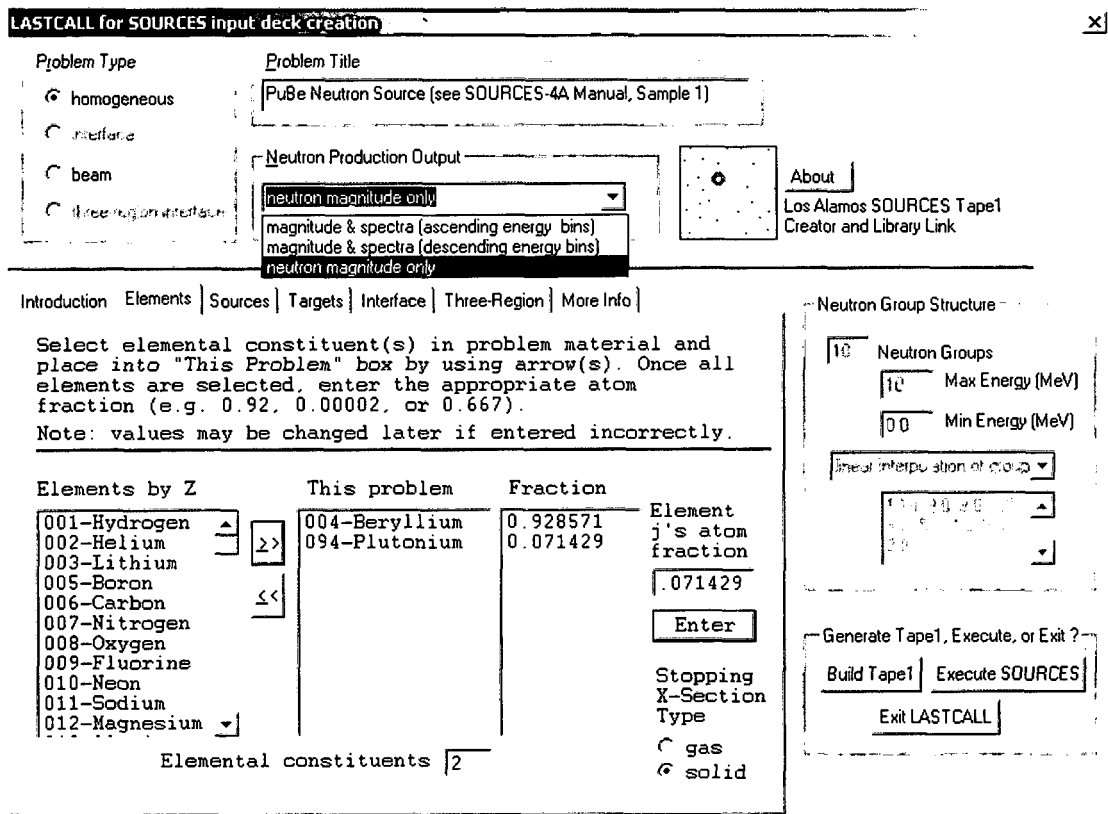

Fig. 9. "Elements" tab is displayed. Note the "Neutron Production Output" selections.

After viewing some introductory material on the first tab (Figure 8), the elemental constituents for the problem may be selected on the second "Elements" tab (Figure 9). One or multiple elements may be selected from the list box "Elements by Z" and moved into "This Problem" (or vice versa) using the arrow(s). The "Elemental constituents" box summarizes the number of elements selected. The atom fraction for each element is required and may be entered via the box labeled "Element j's atom fraction". Clicking the "Enter" button transfers the entry into the "Fraction" box. Presently, this primitive entry mechanism has no method for correction. In other words, any mistakes may not be corrected until the *tape1* file is viewed. At that point, manual corrections may be made. The fractions must be entered in the order of the elements listed in the problem box. Any

entries made surpassing the number of elements will be ignored. This tab also provides the option to select solid or gas stopping cross sections. For the sample problem, we've selected two elements (beryllium and plutonium), entered their appropriate atom fractions (0.928571 and 0.071429, respectively), and chosen solid cross sections.

The third tab, "Sources", allows selection of alpha emitters existing in the problem (Figure 10). In this case, an atom density, rather than atom fraction, must be entered for each alpha source. Practically speaking, these fields are identical to those on the element tab. Had this problem been a "beam" type in lieu of a "homogeneous mixture", the "Beam Energy" field would be required. In that case, the other source fields would become disabled. For the sample problem, six plutonium isotopes were selected and appropriate atom densities entered.

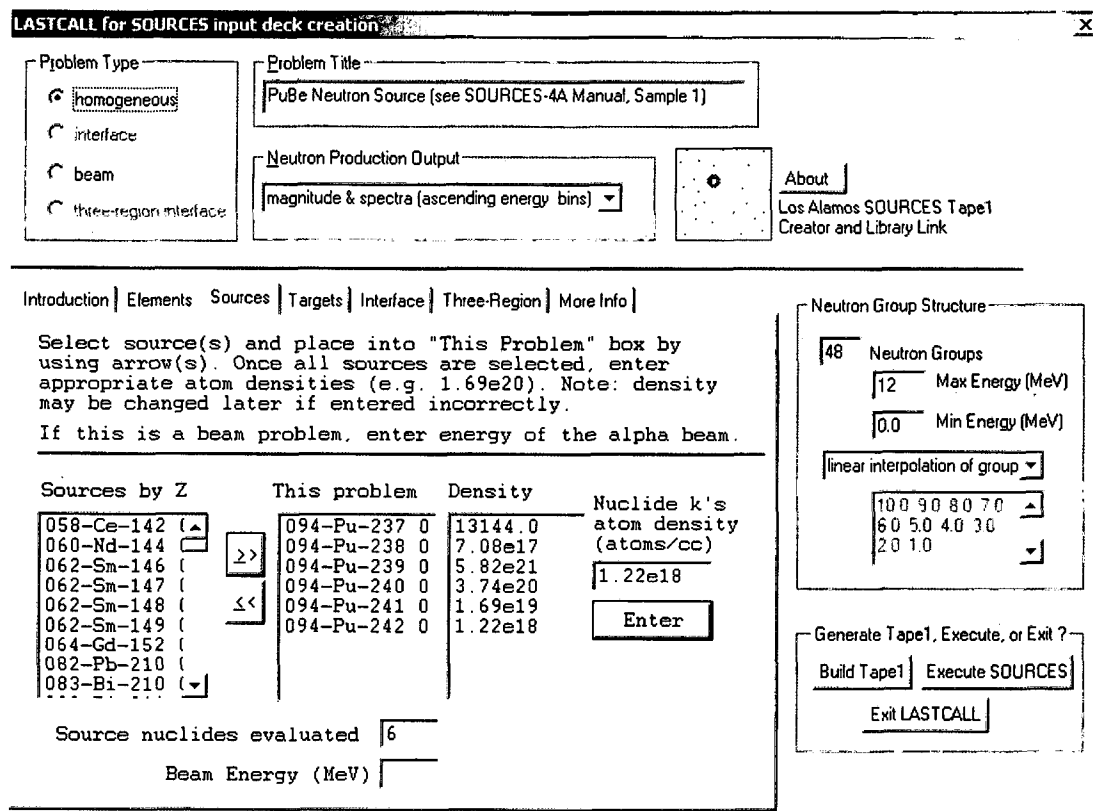

Fig. 10. The "Sources" tab is displayed. Six Pu isotopes were selected.

At this point (Figure 10), we've elected to change the neutron production output to that revealing an energy spectrum in ascending energy bins. This selection made the sixth

region of the dialog window ("Neutron Group Structure") active. The default number of groups was subsequently increased from 10 to 48. The "linearly interpolated" default between a newly modified energy range (0.0-12.0 MeV) was accepted. A pull-down menu reveals a user-defined energy structure option allowing entry of bin limits in the provided area. Such a user-defined description may not appear convenient on the generated tape1 (it is written on one continuous line) and may be manually reformatted into multiple lines.

The "Target" tab functions (Figure 11) are analogous to the preceding two tabs. Multiple targets may be selected and appropriate atom fractions entered. This tab also allows deviation from the default number of alpha energy groups (4000). A singular target (beryllium) was selected for the sample problem. Incidentally, the atom fraction (0.928571) is derived under the assumption this Pu-Be neutron source took the form of an intermetallic alloy (e.g. PuBe₁₃). The fraction of beryllium, therefore, is 13/14.

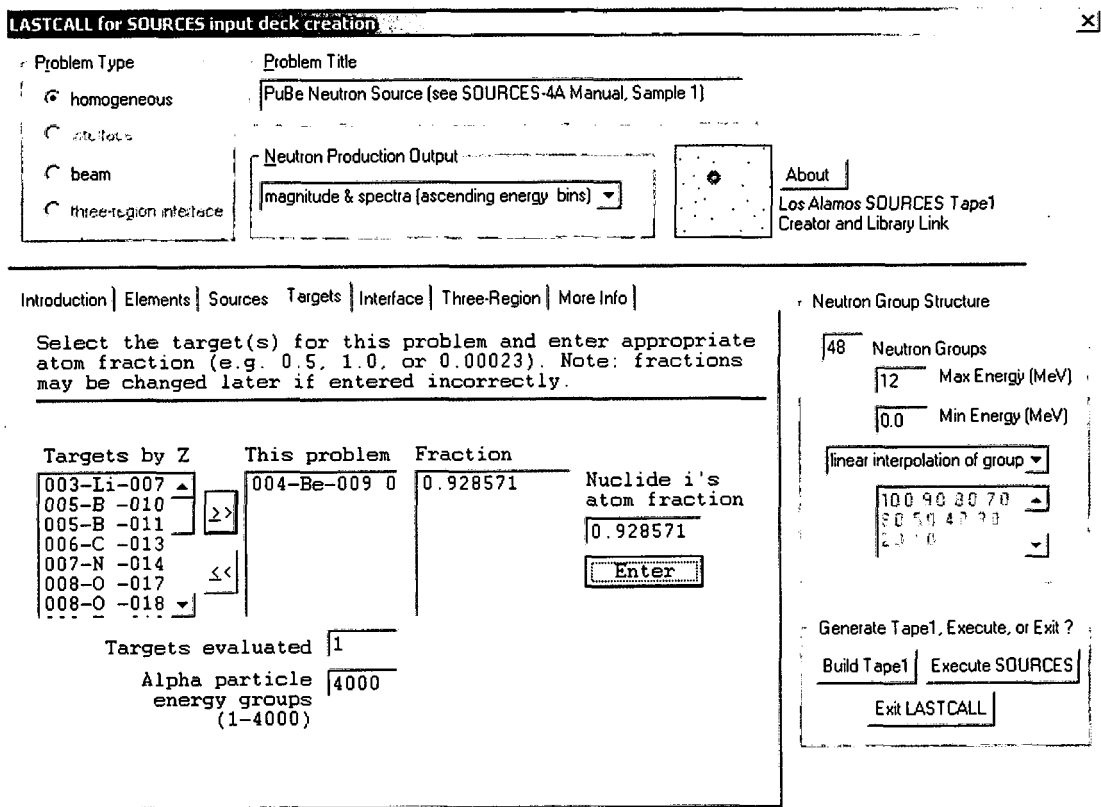

Fig. 11. Beryllium was selected on the "Target" tab.

Three additional tabs (“Interface”, “Three-Region”, and “More Info”) provide supplementary comments (Figure 12).

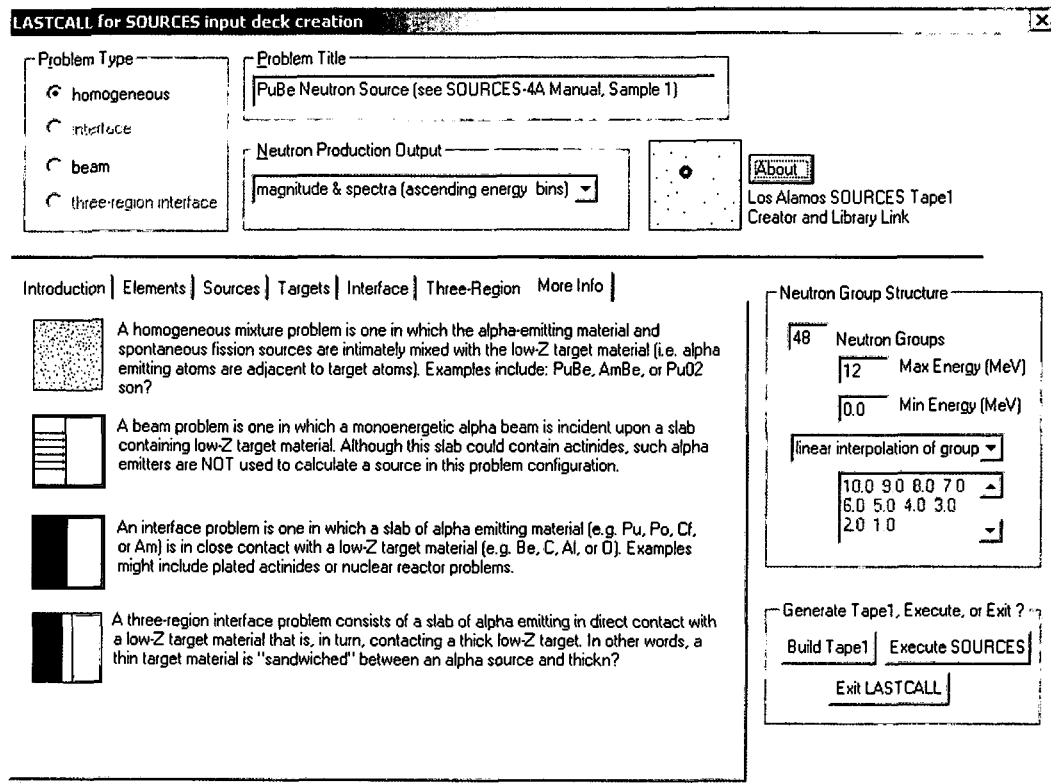

Fig 12. Further information on problem types may be found on the "More Info" tab.

After describing the problem, the user may then consider the seventh section, “Generate Tape1, Execute, or Exit?” This section consists of three buttons. Building the *tape1* files automatically opens the Microsoft® Notepad application to display the *tape1* file (Figure 13). The user may continue to manually edit *tape1*, as necessary, and may save the file under a name other than *tape1* for later manipulation or file organization purposes. Indeed, the primitive nature of this first generation interface may force additional editing, as a mechanism to correct for mis-entry does not currently exist. Figure 13 is nearly identical to the Sample Problem #1 input deck (shown in Figure 15, below) and represents successful execution of LASTCALL.

Although creating the input file satisfies LASTCALL’s intent, the user may now choose to execute SOURCES from the window, or exit the program. Upon successful execution, the generated output files may be used in the Microsoft® Notepad application;

tape6 and *outp* in the case of a “magnitude only” calculation, and *outp*, *outp2*, and *tapes6-9* in a “magnitude and spectra” calculation. Figure 14 displays a portion of the *outp2* file.

To close the application, the user simply clicks the “Exit LASTCALL” button.

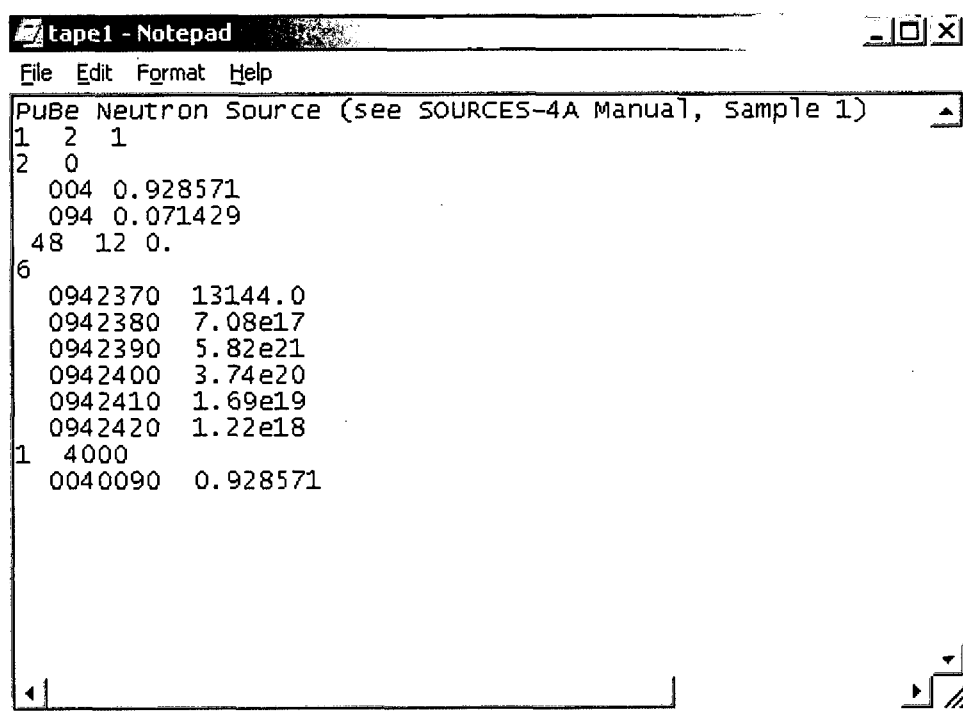

```
File Edit Format Help
PuBe Neutron Source (see SOURCES-4A Manual, Sample 1)
1 2 1
2 0
  004 0.928571
  094 0.071429
48 12 0.
6
  0942370 13144.0
  0942380 7.08e17
  0942390 5.82e21
  0942400 3.74e20
  0942410 1.69e19
  0942420 1.22e18
1 4000
  0040090 0.928571
```

Fig. 13. The product of "Building Tape1" is the automatic opening of the Notepad application to display *tape1*. This example is nearly identical to "Sample Problem #1" in the SOURCES manual.

F. Execution

To execute the SOURCES 4C code, one simply runs the executable file (e.g. sources4C.exe). Alternatively, the code may be executed via LASTCALL as previously discussed. The input deck must be named *tape1*, and the library files must be named *tape2* through *tape5*. After execution, SOURCES 4C displays a STOP message informing the user whether the code was executed normally or if any errors existed during execution. In many cases, the STOP message will inform the user of the cause of any execution error.

Should an error occur during execution, the user should first check the newly created *outp* file (see Section V) as it summarizes the input read from *tape1*. The majority of errors from SOURCES 4C result from an improperly constructed input deck. A common error, for example, occurs when SOURCES 4C attempts to run a problem for which isotopic data does not exist. The user should compare a ZAID specified in *tape1* with the isotopes listed in Tables I and II.

While attempting to correct any errors, user modifications to the library files should be considered only as a last resort.

G. Checklist for Proper Execution

To minimize errors encountered while running SOURCES, this section has a brief checklist that may be helpful in preparing a calculation. Analogous to the popular Monte Carlo code MCNP's™ checklist for input deck preparation, this section also divides a calculation into three phases: problem setup, pre-production, and final calculation phase.

During the problem setup phase:

- Consider using LASTCALL, the graphical user interface for SOURCES
- Is the proper problem type selected (idd=x)?
- Consider physics inherent to the problem
- Is an energy spectrum desired as output (id=2)?
- If so, are neutron spectra desired in ascending order for later use (erg=1)?
- Are the target isotopes listed in ascending order?
- Does all isotopic data exist (see Tables I and II)?
- Are neutron energy groups (if desired) listed in descending order?
- Does the beam energy (idd=3) exceed 6.5 Mev?
- Remember, “Garbage in always equals garbage out!”

For the pre-production phase, after the input file is constructed:

- Run a problem or two
- Does the problem execute normally?
- If error messages are encountered—read the manual!
- Examine results and consider variable changes (e.g. targets, number densities)
- Study the output files (and any effects from variable changes)
- Consider any warning messages
- Is the information in *outp* consistent with that of *tape1*?
- Can a quick hand calculation lend credence to the results?

Finally, during the final phase:

- Execute SOURCES with the desired input deck
- Remember to save the input deck (*tape1*) for later runs, if necessary
- Does the answer seem reasonable?
- Are there suggestions for code or data improvement?
- If so, contact Erik F. Shores at Los Alamos <eshores@lanl.gov>

V. DESCRIPTION OF OUTPUT

Pending the neutron source output requested, SOURCES 4C may create between two and six output files. If the input deck (*tape1*) specifies a magnitudes only problem (*id=1*), then only two output files, *outp* and *tape6*, are created. If neutron source spectra (*id=2*) are requested, then all the files specified in Section III are created (*tape6* through *tape9*, *outp* and *outp2*). An exception exists for interface or TRI (check) problems in which *tape9* is not created. The source α -particles on the target side of such problems may have numerous groups and would make a rather large file. Each output file has a header summarizing the contents of each file and a card listing the problem title.

The file *outp* contains a summary of the input deck as read by SOURCES 4C and of the neutron source output generated. The user should always check this file after running SOURCES 4C to ensure all input was read as intended. The file *outp* also lists the neutron source strengths and average energies by decay mode and total for all modes. Lastly, *outp* shows the portion of the neutron source rates included in the neutron spectrum calculations [for total, (α,n), spontaneous fission, and delayed neutron spectra, when necessary]. In other words, the ratio of the neutron source magnitude calculated by a summation over all energy groups, to the total calculated neutron source magnitude is provided. This value is a measure of how well the energy structure was chosen. If the value is below 90% percent, the energy structure may have been chosen with *enmax* significantly less than the maximum neutron energy produced in the system. In this case, the user may want to choose a different energy structure with a larger group 1 upper bound. The *outp* files for Example Problems #1, #2, #4, #6, #7 and #8 are provided in Appendix A.

The *tape6* file lists the neutron source magnitudes by target nuclide and by source α -particle. The file contains up to three tables labeled Table I, Table II, and Table III. These tables report the neutron production rates from (α,n) reactions, spontaneous fission, and delayed neutron emission in that order. The tables have appropriate headings for the neutron production parameters with units included. The *tape6* files for the input decks associated with Example Problems #1, #4 and #6 are listed in Appendix A.

The *tape7* file lists the absolute neutron spectra (e.g., neutrons per second per unit volume per unit energy). This file begins with the multigroup neutron spectrum (i.e., the energy bounds) used in the calculations. This spectrum may be increasing or decreasing based on the *erg* record. Following that are the absolute neutron spectra (listed by neutron/target combination) coinciding with the group structure specified at the beginning of the file. Totals per target nuclide for (α ,n) reactions, totals for all (α ,n) reactions, totals for spontaneous fission neutrons, and totals for delayed neutrons are also listed (if applicable). The file *tape8* is similar to *tape7* except normalized neutron spectra are reported. *Tape9* lists the energy dependent neutron production rates by target nuclide and by product nuclide level. Again, the neutron energy group structure is listed first and then a breakdown of the neutron energy spectra with target nuclide totals is reported. The *tape7* output files corresponding to the input files listed in Example Problems #2, #4, #6, #7 and #8 are included in Appendix A, as well as the *tape9* output files for Example Problems #2 and #6.

VI. SAMPLE PROBLEMS

Several sample problems are listed below. These problems are available to guide the user towards proper construction of an input deck (*tape1*). The problems were executed to model experimental arrangements, and measured data are reported with the SOURCES 4C calculation when available.

A. Homogeneous Mixtures

1. Sample Problem #1

This problem illustrates the neutron source magnitudes and spectra from a PuBe₁₃ source. The neutron source assumes the form of an inter-metallic alloy (elemental constituents are ¹³/₁₄ Be and ¹/₁₄ Pu) with six isotopes of plutonium (Pu-237, Pu-238, Pu-239, Pu-240, Pu-241, and Pu-242) and one isotope of Be (Be-9) present. The example solves for the magnitude and spectra (*id=2*) and uses a 48 group neutron energy structure (*nng=48*) which is linearly interpolated between 12.0 (*enmax*) and 0.0 (*enmin*) MeV. The six plutonium isotopes are used as sources (*nq=6*) while one beryllium isotope makes up the target (*nt=1*). The atom fractions and densities can be entered in scientific or decimal notation. This input deck is an appropriate model of the experimental measurement performed by L. Stewart.¹⁸

```
Sample 1 - PuBe13 Source (Stewart, 1953)
1 2 1
2 0
  4 0.928571
  94 0.071429
48 12.0 0.0
6
  942370 13144.0
  942380 7.08e+17
  942390 5.82e+21
  942400 3.74e+20
  942410 1.69e+19
  942420 1.22e+18
1 4000
  40090 0.928571
```

Fig. 15. Sample Problem #1 Input Deck.

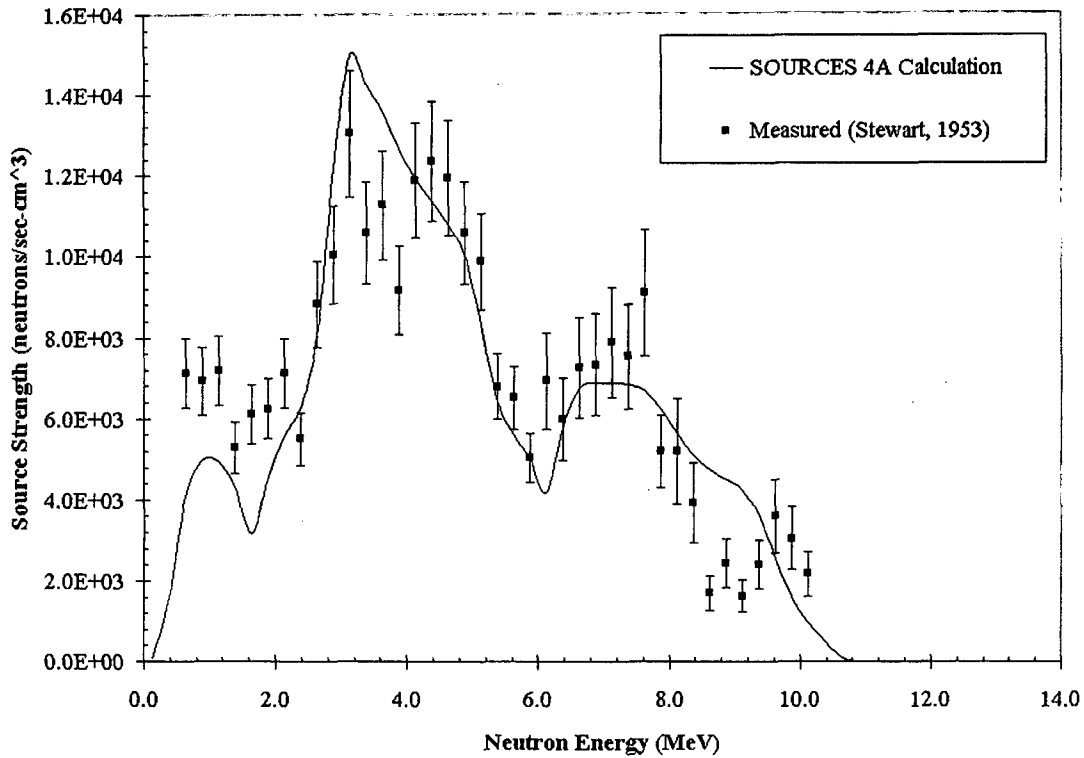

Fig. 16. Energy-Dependent Neutron Source Strength in PuBe₁₃ Homogeneous Problem as Calculated by SOURCES 4C and Compared with Measured Data.

A comparison of the data measured by the experimenters and the SOURCES 4C calculation is presented in Fig. 16. To construct this plot, the histogram output from SOURCES 4C was converted to a continuous distribution using the midpoint energy for each energy group. This conversion was repeated for all energy-dependent neutron source plots in this section. The total neutron source magnitude calculated by SOURCES 4C was 2.69×10^5 neutrons/s-cm³, whereas the experimenters reported a total neutron source rate of 2.28×10^5 neutrons/s-cm³. This magnitude of agreement ($\pm 17\%$) is typical for a SOURCES 4C calculation. From Fig. 16, reasonable agreement between the SOURCES 4C spectrum calculation and measured values is found. The calculation neglected any source contaminants (esp., Am-241) as they were not specified in the published experiment.

2. Sample Problem #2

Several experiments have been performed to analyze criticality accidents involving uranium-containing solutions. These experiments have been primarily interested in gross measurements of k_{eff} . However, a 1991 measurement by Seale and Andersen¹⁹ recorded neutron production rates from uranyl fluoride and uranyl nitrate. The researchers' data for uranyl fluoride was found to be reproducible in several different samples, all of different total volumes. Thus, the uranyl fluoride experiment was chosen for modeling by SOURCES 4C. A calculation was performed using the data listed by the experimenters. The solution was uranyl fluoride (UO_2F_2) with a density of 2.16 g/ml. The uranium concentration consisted of 5% U-235 by weight. The SOURCES 4C input deck for this problem is listed in Fig. 17. The source nuclides included U-234, U-235, and U-238. As the researchers listed no contaminants, none were included in the calculation. The three (α,n) target nuclides shown are O-17, O-18, and F-19. As a result of its negligible (α,n) reaction cross section O-16 was not included. After execution, SOURCES 4C reported a neutron production rate of 0.0467 neutrons/s-cm³. The experimenters had measured a neutron production rate of 0.0421 ± 0.0016 neutrons/s-cm³. This yields a discrepancy between the SOURCES 4C calculation and the experimentally measured value of 11%. This is generally considered good agreement for such a calculation.

```
Sample 2 - Uranyl-Fluoride Solution (Seale, 1991)
1 1 1
3 0
    8 0.4
    9 0.4
    92 0.2
3
  922340 1.32e+17
  922350 2.11e+20
  922380 4.01e+21
3 4000
  80170 0.000152
  80180 0.0008
  90190 0.4
```

Fig. 17. Sample Problem #2 Input Deck.

```

Sample 3 - PoBe Source (Speck, 1944)
1 2 1
2 0
      4 0.99999886
      84 0.00000114
60 12.0 0.0
1
      842100 6.38e+16
1 4000
      40090 0.99999886

```

Fig. 18. Sample Problem #3 Input Deck.

3. Sample Problem #3

Using the photographic emulsion method, researchers at Los Alamos National Laboratory measured the neutron energy spectrum from a Po-Be source.²⁰ The source was a mixture of Po and Be metals in the shape of a cylinder $\frac{3}{8}$ " in diameter and $\frac{1}{4}$ " in height. The total source activity of 100 mCi was reported by the researchers. This source configuration was modeled as a homogeneous source problem using SOURCES 4C. The input deck (*tape1*) used in this calculation is shown in Fig. 18. The problem was executed to acquire the neutron source energy spectrum plotted in Fig. 19.

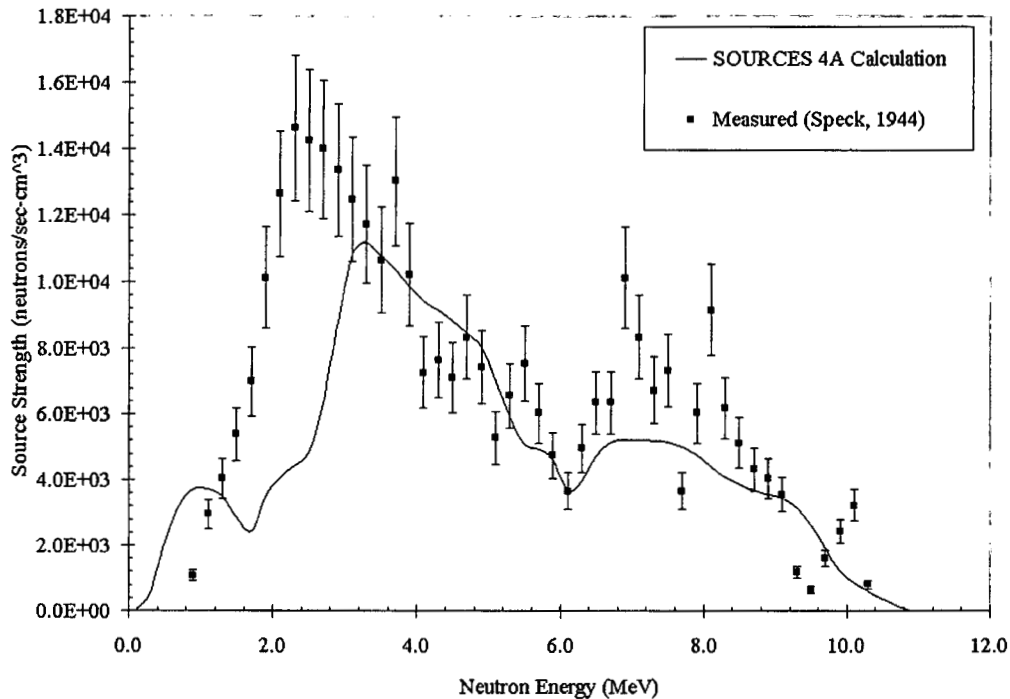

Fig. 19. Energy-Dependent Neutron Source Strength in Po-Be Homogeneous Problem as Calculated by SOURCES 4C and Compared to Measured Data.

Analysis of the data in Fig. 19 shows that the SOURCES 4C calculation appears to overestimate the average neutron energy produced from the sample. On further analysis, it can be found that a Po-Be source, though a mixture of α -emitting material and (α ,n) target material, is composed of grains of Po and grains of Be. These grains have an average diameter significantly larger than the α -particle range. Thus, it is postulated that a Po-Be source is more properly modeled as an interface problem of Po and Be. This theory is supported by the calculations performed in Sample Problem #5.

The outcome of this problem is extremely important. The user must be aware of the physics inherent to the problem being modeled. In the case of Sample Problems #1 and #2, the materials were compounds (PuBe_{13} or UO_2F_2). Thus, the α -emitting nuclides and (α ,n) target nuclides are intimately mixed. For Po-Be, the material has a tendency to clump into grains, and the grain size of the metals can and will affect the outcome of the calculations. It is imperative, therefore, that users consider the chemical nature of the problem's constituents prior to constructing the input deck.

B. Interface Problem Examples

1. Sample Problem #4

In 1944, a study was conducted by Perlman *et al.*²¹ at Los Alamos National Laboratory to explore the possibility of using an (α ,n) neutron source to simulate a fission neutron spectra. In this study, a series of platinum foils (3 x 3 cm) were coated with 180 mCi of Po and interleaved between sintered B_4C slabs. The entire Po- B_4C assembly was placed in a brass box and sealed under a slight vacuum. The resultant neutron energy spectrum from the source was measured using the photographic emulsion method. A schematic of the experimental setup is shown in Fig. 20.

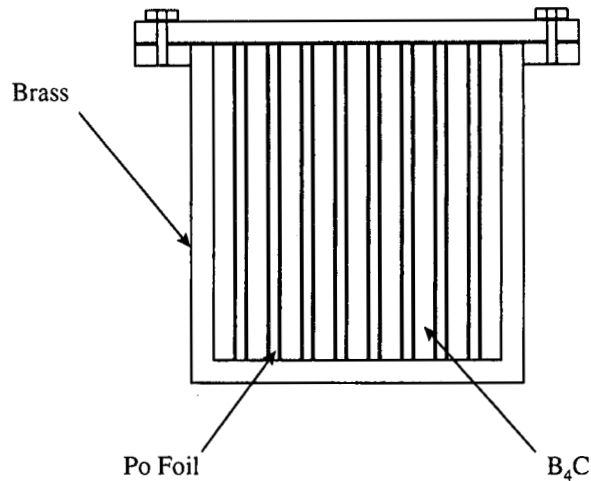

Fig. 20. Po-B₄C Source Arrangement for Sample Problem #4.

To model this arrangement, a SOURCES 4C input deck (Fig. 21) was constructed using the interface problem capabilities of SOURCES 4C (*idd=2*). The atomic fractions listed in the input deck show that natural boron (19.9% B-10 and 80.1% B-11) and carbon (98.9% C-12 and 1.1% C-13) were used. Also the α -particle source was set to include 100% Po-210. This input deck was executed to solve for the neutron source spectra and magnitudes (*id=2*) resulting from the (α ,n) interactions in the boron carbide.

```

Sample 4 - Po-B4C Interface Experiment (Perlman, 1944)
2 2 1
1 0 10.0 0.0000001
      84 1.0
50
1
      842100 1.00
target is a B4C slab
2 0
      5 0.8
      6 0.2
50 10.0 0.0
3 4000
      50100 0.1592
      50110 0.6408
      60130 0.0022

```

Fig. 21. Sample Problem #4 Input Deck.

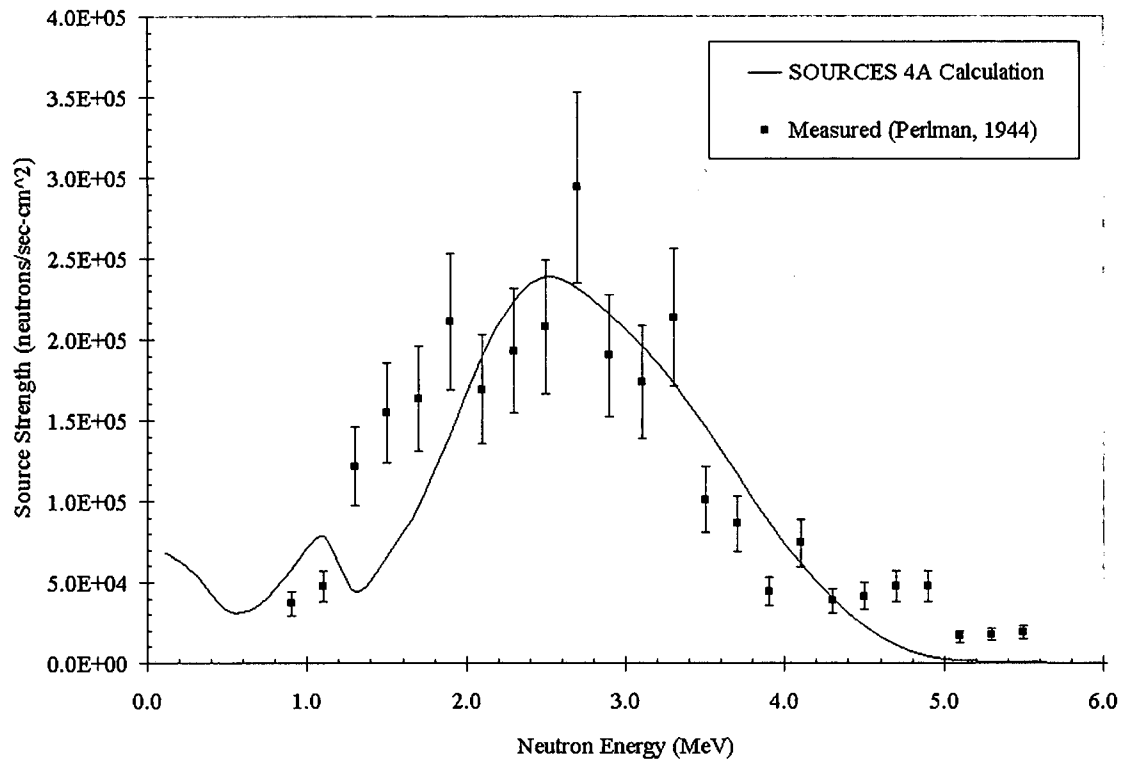

Fig. 22. Energy-Dependent Neutron Source Strength in Po-B₄C Interface Problem as Calculated by SOURCES 4C and Compared to Measured Data.

The energy spectrum of the calculated Po-B₄C neutrons is plotted in Fig. 22, along with the measured data. The agreement between the measured data and the SOURCES 4C calculation is reasonable and typical of an interface problem. The addition of contaminants and other Po isotopes could greatly affect the shape of this spectrum. It is important to note that the researchers did not specify the presence of any contaminants in the samples.

2. Sample Problem #5

In Sample Problem #3, a Po-Be source was investigated as a possible homogeneous problem. It was discovered that the energy spectrum of the neutrons calculated by SOURCES 4C was shifted to a higher average energy than what was reported by the experimenters.²⁰ It was suggested that this shift was due to the grain structure of the materials in Po-Be sources. To verify this hypothesis, SOURCES 4C was used to model

the identical experiment using its interface capabilities. The Po-Be input deck used for this model is shown in Fig. 23. The figure shows that the entire source side is composed of Po-210, and the entire target side is composed of a Be-9. The neutron energy group structure is the same as that used in Sample Problem #3.

```

Sample 5 - Po-Be Interface Experiment (Speck, 1944)
2 2 1
1 0 10.0 0.000001
      84 1.0
50
1
      842100 1.00
target is a Be slab
1 0
      4 1.0
60 12.0 0.0
1 4000
      40090 1.0

```

Fig. 23. Sample Problem #5 Input Deck.

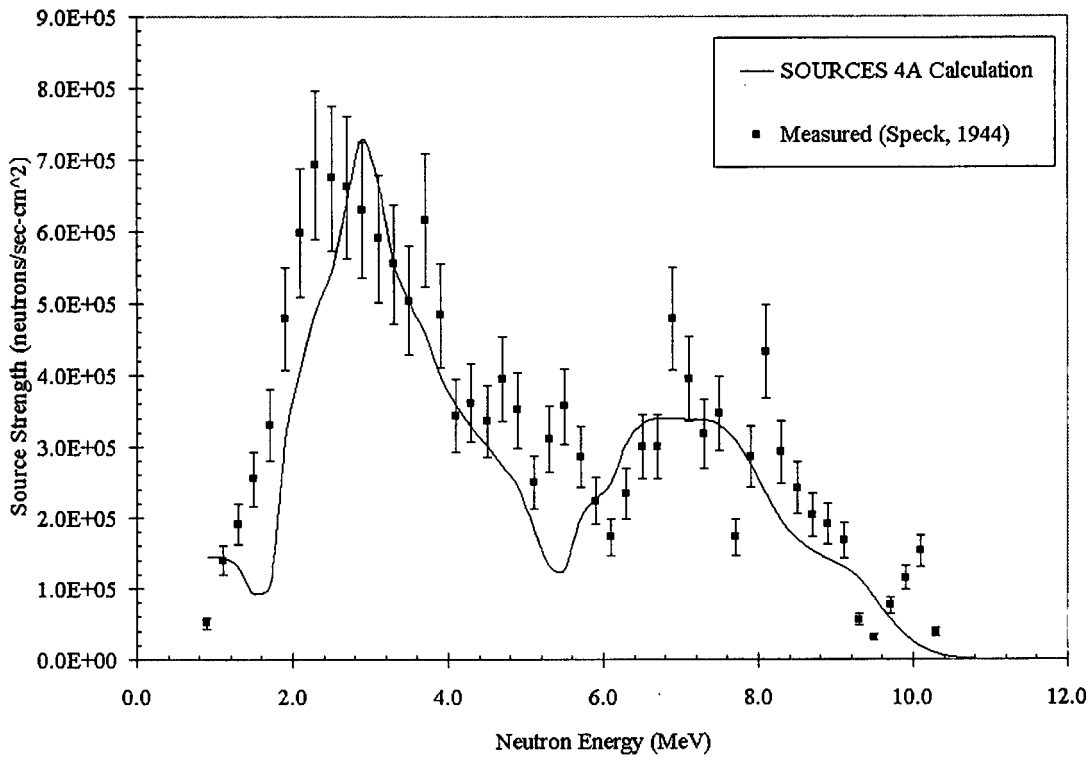

Fig. 24. Energy-Dependent Neutron Source Strength in Po-Be Interface Problem as Calculated by SOURCES 4C and Compared to Measured Data.

The output from the execution of Sample Problem #5 was plotted with the experimental data (Fig. 24). The SOURCES 4C calculation and measured values appear to agree within a good degree of accuracy. This supports the theory that a Po-Be (α,n) source is affected by the grain structure of its metal components. It is important that any SOURCES 4C users consider this type of problem when modeling any realistic (α,n) sources.

C. Beam Problem Examples

In 1983, researchers in Belgium used a 7 MV Van de Graaff accelerator and an NE213 liquid scintillator to analyze the energy spectra of neutrons produced by 4 to 5.5 MeV α -particles on thick targets of light elements (e.g., C, O, Mg, F, Al, Si, Al₂O₃, and SiO₂).²² The experimenters measured the energy spectra of neutrons in 0.1 MeV bins and reported these spectra, the total neutron yields per incident α -particle, and the average neutron energies for each sample. Two samples bombarded by the experimenters are modeled below using SOURCES 4C. The first sample was aluminum oxide (Sample Problem #6) and the second sample was pure magnesium (Sample Problem #7). The measured and calculated data for each are plotted in Figs. 26 and 28. Also, the average neutron energy and the total neutron yield per incident α -particle are reported.

1. Sample Problem #6

The input deck used for modeling the bombardment of aluminum oxide by 5.0 MeV α -particles is listed in Fig. 25. The energy structure is divided into 55 bins of 0.1 MeV width; however, the lower energy cutoff is above 0.0 MeV.

```

Sample 6 - Alpha Beam (5.0 MeV) on Al2O3
3 2 1
2 0
      8 0.6
      13 0.4
55 5.55 0.05
5.0
3 4000
      80170 0.000228
      80180 0.0012
      130270 0.4

```

Fig. 25. Sample Problem #6 Input Deck.

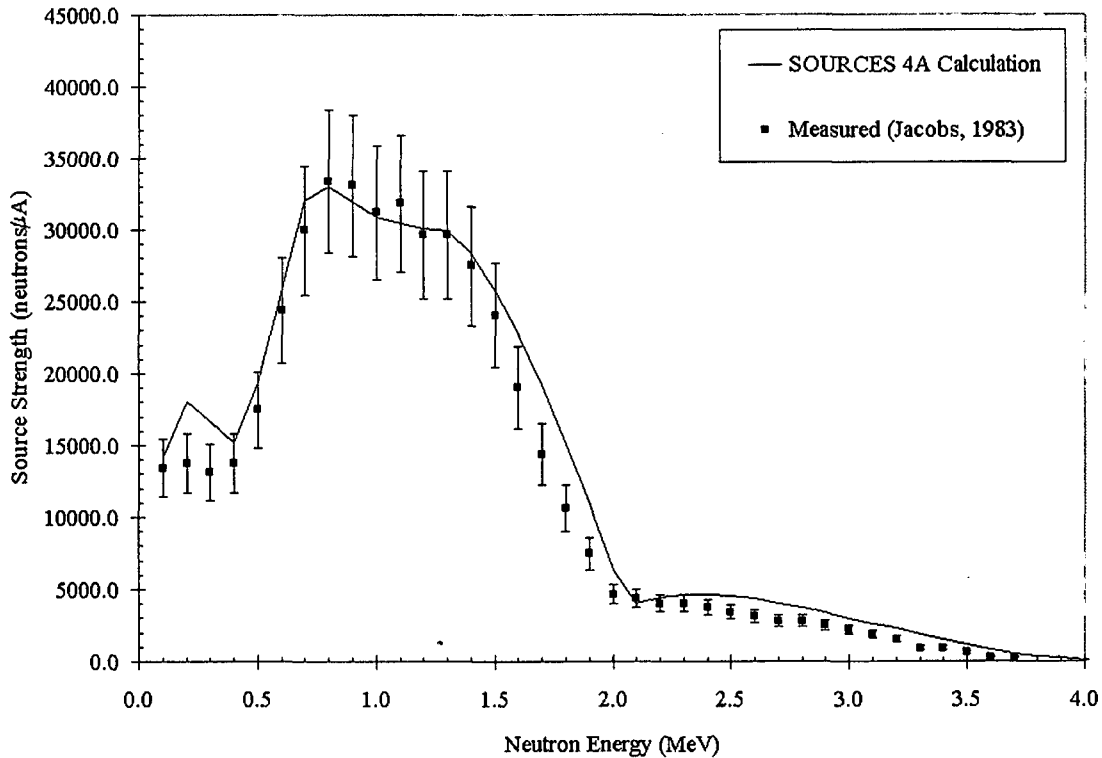

Fig. 26. Energy-Dependent Neutron Source Strength from 5.0 MeV α -Particles Incident on Aluminum Oxide Slab as Calculated by SOURCES 4C and Compared to Measured Data.

The total neutron yield per incident α -particle was reported by the experimenters to be 1.58×10^{-7} neutrons/ α -particle.²² The SOURCES 4C calculation output a value of 1.63×10^{-7} neutrons/ α -particle. The measured average neutron energy was 1.14 ± 0.04 MeV whereas SOURCES 4C reported an average energy of 1.35 MeV. As can be seen, the total neutron yields agree to within 4%. The energy-dependent neutron spectra are plotted in Fig. 26. The neutron spectra have a few small discrepancies, and the average neutron energies show an 18% difference; however the agreement is generally very good. The SOURCES 4C total neutron yields consistently have better agreement to measured data than the spectral calculations. However, as is shown here and in Sample Problem #7, for beam problems the SOURCES 4C calculations are excellent for both magnitudes and spectra.

2. Sample Problem #7

The input deck used for modeling the magnesium irradiation by 5.5 MeV α -particles is shown in Fig. 27. The magnesium sample contains two naturally occurring isotopes (Mg-25 and Mg-26) as (α ,n) target nuclides. The isotope Mg-24 was neglected due to its negligible (α ,n) cross section. The neutron energy group structure consisted of 81 energy groups in 0.1 MeV bins.

```

Sample 7 - Alpha Beam (5.5 MeV) on Mg
3 2 1
1 0
      12 1.0
81 8.15 0.05
5.5
2 4000
  120250 0.10
  120260 0.1101
    
```

Fig. 27. Sample Problem #7 Input Deck.

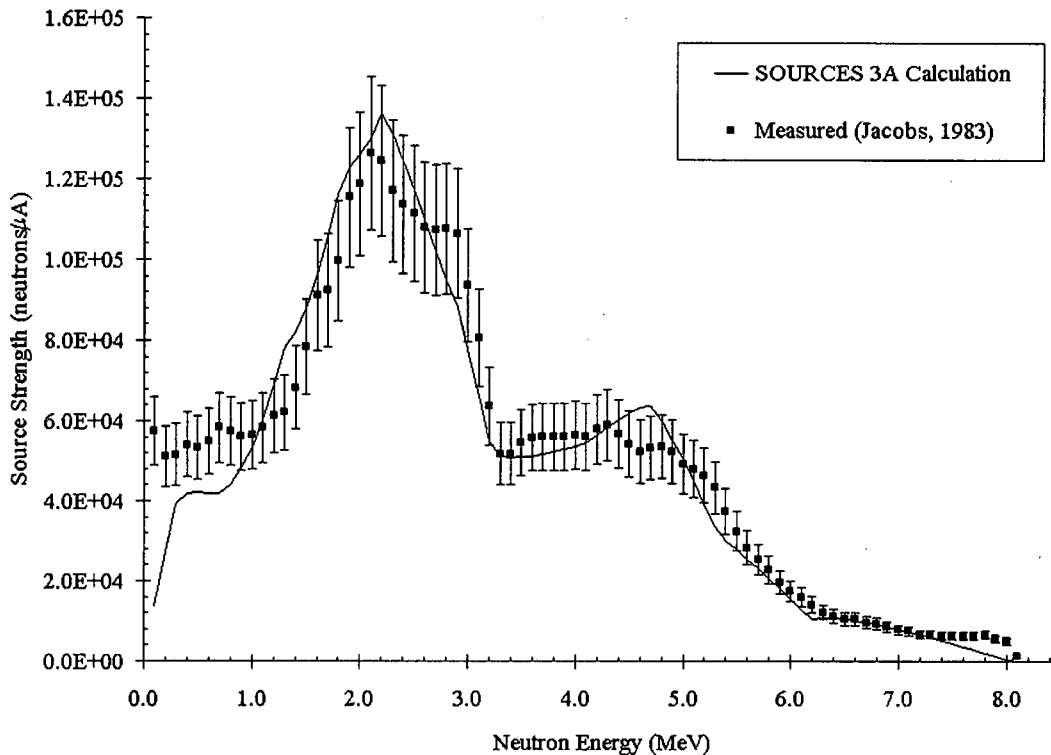

Fig. 28. Energy-Dependent Neutron Source Strength from 5.5 MeV α -Particles Incident on Magnesium Slab as Calculated by SOURCES 4C and Compared to Measured Data.

The total neutron yield per incident α -particle was reported by the experimenters to be 1.33×10^{-6} neutrons/ α -particle.²² The SOURCES 4C calculation output a value of 1.27×10^{-6} neutrons/ α -particle. The measured average neutron energy was 2.85 ± 0.12 MeV, where as SOURCES 4C reported an average energy of 3.04 MeV. The total neutron yields agree to within 5%. The energy-dependent neutron spectra are plotted in Fig. 28. The measured and calculated neutron energy spectra have excellent agreement (within experimental error).

VII. ACKNOWLEDGMENTS

The present version of SOURCES would not be possible without the contributions of many people. In particular, A. Andrade and D.W. Lee supported this work at Los Alamos and their efforts are acknowledged and appreciated. In addition, J.A. Sattelberger deserves thanks for her assistance during various stages of the upgrade process.

VIII. REFERENCES

1. R. T. PERRY and W. B. WILSON, "Neutron Production from (α ,n) Reactions and Spontaneous Fission in ThO₂, UO₂ and (U,Pu)O₂ Fuels," Los Alamos National Laboratory report LA-8869-MS (1981). [included in Appendix D]
2. W. B. WILSON, R. T. PERRY, J. E. STEWART, T. R. ENGLAND, D. G. MADLAND, and E. D. ARTHUR, "Development of the SOURCES Code and Data Library for the Calculation of Neutron Sources and Spectra from (α ,n) Reactions, Spontaneous Fission, and β^- Delayed Neutrons," Los Alamos National Laboratory Report LA-9841-PR, page 65 (1983).
3. H. J. HIRSCH and H. J. MATZKE, "Stopping Power and Range of α -Particles in (U,Pu)C and UC and Application to Self-Diffusion Measurements Using Alpha Spectroscopy," *J. of Nucl. Mater.* **45**, page 29 (1972).
4. W. H. BRAGG and R. KLEEMAN, "On the Alpha Particles of Radium and their Loss of Range in Passing through Various Atoms and Molecules," *Phil. Mag.* **10**, page 318 (1905).
5. B. G. WHITMORE and W. B. BAKER, "The Energy Spectrum of Neutrons from a Po-Be Source," *Phys. Rev.* **78**, page 799 (1950).
6. T.R. ENGLAND, et al., "Aggregate Delayed Neutrons and Spectra Using Augmented ENDF/B-V Precursor Data," Los Alamos National Laboratory Report LA-UR-83-1270 (1983).
7. W. S. CHARLTON, R. T. PERRY, G. P. ESTES, and T. A. PARISH, "Derivation and Implementation of the Three-Region Problem in the Sources Code System," *J. of Nucl. Sci. and Tech.*, Supplement 1, p. 570-574 (2000).

8. J. H. GIBBONS and R. L. MACKLIN, "Total Neutron Yields from Light Elements Under Proton and Alpha Bombardment," *Phys. Rev.*, **114**, page 571 (1959).
9. K. W. GEIGER and L. VAN DER ZWAN, "An Evaluation of the $^9\text{Be}(\alpha,n)$ Cross Section," *National Research Council Canada, NRCC-15303*, page 12 (1976).
10. J. K. BAIR and J. GOMEZ DEL CAMPO, "Neutron Yields from Alpha Particle Bombardment," *Nucl. Sci. and Eng.* **71**, page 18 (1979).
11. J. K. BAIR and F. X. HAAS, "Total Neutron Yield from the Reaction $^{13}\text{C}(\alpha,n)^{16}\text{O}$ and $^{17,18}\text{O}(\alpha,n)^{20,21}\text{Ne}$," *Phys. Rev. C* **7**, page 1356 (1973).
12. D. L. LESSOR and R. E. SCHENTER, "Neutron Spectra from (α,n) Reactions in Plutonium Compounds Calculated from Hauser-Feshbach Reaction Theory," Brookhaven National Laboratory report BNWL-B-109 (1971).
13. E.B. NORMAN, T.E. CHUPP, P.J. GRANT and G.L. Woodruff, " ^{22}Na Production Cross Section from the $^{19}\text{F}(\alpha,n)$ Reaction," *Phys Rev C* **30**, 1339 (1984).
14. S. E. WOOSLEY, W. A. FOWLER, J. A. HOLMES, and B. A. ZIMMERMAN, OAP-422 (1975).
15. J. F. ZIEGLER, "Helium Stopping Powers and Ranges in All Elemental Matter," Vol. 4 of *The Stopping Power and Ranges of Ions in Matter Series*, Pergammon Press, New York (1977).
16. R.B. FIRESTONE and V.S. SHIRLEY, Ed., "Table of Isotopes," Eighth Ed., Wiley-Interscience (1996).

17. E. F. SHORES, "Data Updates for the SOURCES 4A Computer Code," *Nucl. Instr. and Meth. B* **179**, 78-82 (2001).
18. L. STEWART, "Determination of the Neutron Spectrum and Absolute Yield of a Plutonium-Beryllium Source," Master's Thesis, University of Texas (1953).
19. R. L. SEALE and R. E. ANDERSEN, "Intrinsic Neutron Source Strengths in Uranium Solutions," *Trans. Am. Nucl. Soc.* **63**, p. 226 (1991).
20. L. SPECK and H. RICHARDS, "Energy Spectrum of Po-Be Neutrons," Los Alamos Scientific Laboratory Report LA-111 (1944).
21. T. H. PERLMAN, H. T. RICHARDS, and J. H. WILLIAMS, "The Energies of the Neutrons from Polonium Alphas on Boron," Los Alamos Scientific Laboratory Report LA-66 (1944).
22. G. J. H. JACOBS and H. LISKIEN, "Energy Spectra of Neutrons Produced by α -Particles in Thick Targets of Light Elements," *Ann. Nucl. Energy* **10**, page 541 (1983).

APPENDIX A

Output Files for Example Problems

Example Problem #1 (file: *outp*)

SOURCES 4C Calculation
<<<<<<<<<<<<<<>>>>>>>>>>>>

Summary of Input

Title: Example 1 - Clean UO2 Fuel (3% enriched)
Homogeneous problem input (idd = 1)
Magnitudes only computed (id = 1)
Number of elemental constituents: 2
Solid stopping cross-sections used (isg = 0)

Elemental Constituents:

Z-value	Atom Fraction
8	0.6666666865
92	0.3333333135

Number of source nuclides to be evaluated: 2

Source Nuclides:

ZAID	Atom Density (g/cc)
922350	6.770E+20
922380	2.160E+22

Number of target nuclides to be used: 2
4000 Alpha energy groups used.

Target Nuclides:

ZAID	Atom Fraction
80170	2.530E-04
80180	1.333E-03

Summary of Output

Total (alpha,n) neutron source from all sources and targets: 8.921E-04 n/sec-cm³.

Total spontaneous fission neutron source from all sources and targets: 1.163E-01 n/sec-cm³.

Total delayed neutron source from all sources and targets: 0.000E+00 n/sec-cm³.

Total neutron source from all sources and targets: 1.172E-01 n/sec-cm³.

Example Problem #1 (file: tape6)

SOURCES 4C Calculation
<<<<<<<<<>>>>>>>>>>>>>

Neutron Source Magnitudes

Title: Example 1 - Clean UO2 Fuel (3% enriched)

1

Table I

=====

(alpha,n) Neutron Production by Target Per Source Alpha

target	target atom frac.	alpha source	alpha energy	alphas/sec /cm**3	p(e) neut/alpha	neuts/sec /cm**3	
+	o 17	2.5300E-04	u235	4.150	1.9016E+02	6.4428E-10	1.2251E-07
				4.215	1.2043E+03	6.9568E-10	8.3782E-07
				4.271	8.4513E+01	7.2387E-10	6.1177E-08
				4.295	1.9016E+00	7.3545E-10	1.3985E-09
				4.366	3.5918E+03	7.7655E-10	2.7892E-06
				4.398	1.1621E+04	7.9041E-10	9.1850E-06
				4.414	4.4370E+02	7.9693E-10	3.5360E-07
				4.435	1.4790E+02	8.0627E-10	1.1925E-07
				4.502	3.5918E+02	8.3379E-10	2.9948E-07
				4.556	8.8739E+02	8.5739E-10	7.6084E-07
				4.596	1.0564E+03	8.8459E-10	9.3450E-07
+					Total:	1.5465E-05	
	o 17	2.5300E-04	u238	4.038	8.2824E+01	5.5438E-10	4.5916E-08
				4.151	2.2193E+04	6.4518E-10	1.4318E-05
				4.198	8.3886E+04	6.8563E-10	5.7515E-05
+					Total:	7.1879E-05	
+				Total (this target):		8.7344E-05	
	o 18	1.3330E-03	u235	4.150	1.9016E+02	5.8451E-09	1.1115E-06
				4.215	1.2043E+03	6.2273E-09	7.4996E-06
				4.271	8.4513E+01	6.8208E-09	5.7645E-07
				4.295	1.9016E+00	7.1103E-09	1.3521E-08
				4.366	3.5918E+03	7.8205E-09	2.8090E-05
				4.398	1.1621E+04	8.2819E-09	9.6241E-05
				4.414	4.4370E+02	8.5217E-09	3.7810E-06
				4.435	1.4790E+02	8.7905E-09	1.3001E-06
				4.502	3.5918E+02	9.2868E-09	3.3356E-06
				4.556	8.8739E+02	9.7751E-09	8.6743E-06
				4.596	1.0564E+03	1.0300E-08	1.0882E-05
+					Total:	1.6150E-04	
	o 18	1.3330E-03	u238	4.038	8.2824E+01	5.1837E-09	4.2933E-07
				4.151	2.2193E+04	5.8503E-09	1.2983E-04
				4.198	8.3886E+04	6.1155E-09	5.1301E-04
+					Total:	6.4327E-04	
+					Total:	_____	

Total (this target): 8.0477E-04

+

Total (all targets): 8.9212E-04

2

Table II
=====

Spontaneous Fission Neutron Production

source nuclide	source atoms per cm**3	dk constant (/second)	sf decay branching	nu bar	neutrons sec/cm**3
u235	6.7700E+20	3.1209E-17	7.000E-11	1.860	2.751E-06
u238	2.1600E+22	4.9159E-18	5.450E-07	2.010	1.163E-01
Total:					1.163E-01

Example Problem #2 (file: outp)

SOURCES 4C Calculation
<<<<<<<<<>>>>>>>>>>>>>

Summary of Input =====

Title: Example 2 - Clean UO2 Fuel (3% enriched) for Spectra
Homogeneous problem input (idd = 1)
Magnitudes and spectra computed (id = 2)
Ascending energy structure for output (erg = 1)
Number of elemental constituents: 2
Solid stopping cross-sections used (isg = 0)

Elemental Constituents:

Z-value	Atom Fraction
8	0.6666666865
92	0.3333333135

Number of neutron spectrum energy groups: 10
Maximum neutron energy is 1.000E+01 MeV.
Minimum neutron energy is 0.000E+00 MeV.

Energy Group Structure:

Group	Upper-Bound	Lower-Bound
1	1.000E+01	9.000E+00
2	9.000E+00	8.000E+00
3	8.000E+00	7.000E+00
4	7.000E+00	6.000E+00
5	6.000E+00	5.000E+00
6	5.000E+00	4.000E+00
7	4.000E+00	3.000E+00
8	3.000E+00	2.000E+00
9	2.000E+00	1.000E+00
10	1.000E+00	0.000E+00

Number of source nuclides to be evaluated: 2

Source Nuclides:

Z A I D	Atom Density (g/cc)
922350	6.770E+20
922380	2.160E+22

Number of target nuclides to be used: 2
4000 Alpha energy groups used.

Target Nuclides:

Z A I D	Atom Fraction
80170	2.530E-04
80180	1.333E-03

Summary of Output

=====

Total (alpha,n) neutron source from all sources and targets: 8.921E-04 n/sec-cm³.

Total spontaneous fission neutron source from all sources and targets: 1.163E-01 n/sec-cm³.

Total delayed neutron source from all sources and targets: 0.000E+00 n/sec-cm³.

Total neutron source from all sources and targets: 1.172E-01 n/sec-cm³.

Average (alpha,n) neutron energy: 2.012E+00 MeV.

Average spontaneous fission neutron energy: 1.68813E+00 MeV.

Average delayed neutron energy: 0.000E+00 MeV.

Average neutron energy from all sources: 1.691E+00 MeV.

Normalized Neutron Energy Spectrum by Energy Group for All Sources:
(Note: descending group structure is independent of erg record.)

Group	Contribution
-----	-----
1	1.932E-04
2	5.832E-04
3	1.714E-03
4	4.876E-03
5	1.332E-02
6	3.457E-02
7	8.364E-02
8	1.848E-01
9	3.299E-01
10	3.463E-01

Portion of Total Neutron Source Rate Accounted for in the Total Energy Spectrum: 100.0%.

Portion of Spontaneous Fission Neutron Source Rate Accounted For in the Spontaneous Fission Energy Spectrum: 100.0%.

Example Problem #2 (file: tape7)

SOURCES 4C Calculation
<<<<<<<<<<>>>>>>>>>>>>

Absolute Neutron Source Spectra
~~~~~

Title: Example 2 - Clean UO2 Fuel (3% enriched) for Spectra

Neutron Multigroup Structure (MeV)

0.000E+00 1.000E+00 2.000E+00 3.000E+00 4.000E+00 5.000E+00 6.000E+00 7.000E+00  
8.000E+00 9.000E+00 1.000E+01

-----  
(a,n) neutrons/sec-cc from 6.77000E+20 at/cc u235 alphas on o 17 in target  
4.967E-07 6.189E-06 5.875E-06 2.276E-06 6.285E-07 0.000E+00 0.000E+00 0.000E+00  
0.000E+00 0.000E+00

Total (all groups): 1.546E-05 neutrons/sec-cm\*\*3 .  
Average Neutron Energy: 2.267E+00 MeV.

(a,n) neutrons/sec-cc from 2.16000E+22 at/cc u238 alphas on o 17 in target  
2.682E-06 3.163E-05 2.450E-05 1.080E-05 2.275E-06 0.000E+00 0.000E+00 0.000E+00  
0.000E+00 0.000E+00

Total (all groups): 7.188E-05 neutrons/sec-cm\*\*3 .  
Average Neutron Energy: 2.197E+00 MeV.

Total (alpha,n) neutron spectrum this target

3.179E-06 3.782E-05 3.037E-05 1.307E-05 2.904E-06 0.000E+00 0.000E+00 0.000E+00  
0.000E+00 0.000E+00

Total (all groups): 8.734E-05 neutrons/sec-cm\*\*3 .  
Average Neutron Energy: 2.209E+00 MeV.

-----  
(a,n) neutrons/sec-cc from 6.77000E+20 at/cc u235 alphas on o 18 in target  
9.826E-06 5.731E-05 8.697E-05 7.385E-06 0.000E+00 0.000E+00 0.000E+00 0.000E+00  
0.000E+00 0.000E+00

Total (all groups): 1.615E-04 neutrons/sec-cm\*\*3 .  
Average Neutron Energy: 2.067E+00 MeV.

(a,n) neutrons/sec-cc from 2.16000E+22 at/cc u238 alphas on o 18 in target  
3.396E-05 2.839E-04 3.177E-04 7.641E-06 0.000E+00 0.000E+00 0.000E+00 0.000E+00  
0.000E+00 0.000E+00

Total (all groups): 6.432E-04 neutrons/sec-cm\*\*3 .  
Average Neutron Energy: 1.972E+00 MeV.

Total (alpha,n) neutron spectrum this target

4.378E-05 3.412E-04 4.047E-04 1.503E-05 0.000E+00 0.000E+00 0.000E+00 0.000E+00  
0.000E+00 0.000E+00

Total (all groups): 8.047E-04 neutrons/sec-cm\*\*3 .  
Average Neutron Energy: 1.991E+00 MeV.

-----  
-----  
Grand total (alpha,n) neutron spectrum, all targets, all sources

4.696E-05 3.790E-04 4.351E-04 2.810E-05 2.904E-06 0.000E+00 0.000E+00 0.000E+00  
0.000E+00 0.000E+00

Total (all groups): 8.921E-04 neutrons/sec-cm\*\*3 .  
Average Neutron Energy: 2.012E+00 MeV.

-----  
-----  
S.F. neutrons/cc from 6.77000E+20 at/cc u235

8.588E-07 8.541E-07 5.254E-07 2.760E-07 1.326E-07 5.994E-08 2.594E-08 1.085E-08  
4.413E-09 1.756E-09

Total (all groups): 2.750E-06 neutrons/sec-cm\*\*3 .  
Average Neutron Energy: 1.890E+00 MeV.

S.F. neutrons/cc from 2.16000E+22 at/cc u238

4.055E-02 3.829E-02 2.122E-02 9.775E-03 4.049E-03 1.562E-03 5.716E-04 2.009E-04  
6.836E-05 2.264E-05

Total (all groups): 1.163E-01 neutrons/sec-cm\*\*3 .  
Average Neutron Energy: 1.688E+00 MeV.

-----  
-----  
Total S.F. neutron spectrum

4.055E-02 3.829E-02 2.122E-02 9.775E-03 4.049E-03 1.562E-03 5.716E-04 2.009E-04  
6.836E-05 2.264E-05

Total (all groups): 1.163E-01 neutrons/sec-cm\*\*3 .  
Average Neutron Energy: 1.688E+00 MeV.

-----  
-----  
Total Neutron Spectrum

4.060E-02 3.867E-02 2.166E-02 9.804E-03 4.052E-03 1.562E-03 5.716E-04 2.009E-04  
6.836E-05 2.264E-05

Total (all groups): 1.172E-01 neutrons/sec-cm\*\*3 .  
Average Neutron Energy: 1.691E+00 MeV.

## Example Problem #2 (file: *tape9*)

SOURCES 4C Calculation  
 <<<<<<<<<<>>>>>>>>>>>

### Neutron Source Spectra by Nuclide Energy Level

---

Title: Example 2 - Clean UO2 Fuel (3% enriched) for Spectra

Neutron Multigroup Structure (MeV)  
 0.000E+00 1.000E+00 2.000E+00 3.000E+00 4.000E+00 5.000E+00 6.000E+00 7.000E+00  
 8.000E+00 9.000E+00 1.000E+01

---

Neutron spectrum from u235 alphas on o 17 via the 0.00-MeV product level  
 0.000E+00 0.000E+00 0.000E+00 0.000E+00 0.000E+00 6.285E-07 2.255E-06 8.723E-07  
 2.790E-08 0.000E+00

Total (all groups): 3.783E-06 neutrons/sec-cm\*\*3 .  
 Average Neutron Energy: 3.406E+00 MeV.

Neutron spectrum from u235 alphas on o 17 via the 1.63-MeV product level  
 0.000E+00 0.000E+00 0.000E+00 0.000E+00 0.000E+00 0.000E+00 2.116E-08 5.002E-06  
 6.161E-06 4.949E-07

Total (all groups): 1.168E-05 neutrons/sec-cm\*\*3 .  
 Average Neutron Energy: 1.898E+00 MeV.

Neutron spectrum from u235 alphas on o 17 via the 4.25-MeV product level  
 0.000E+00 0.000E+00 0.000E+00 0.000E+00 0.000E+00 0.000E+00 0.000E+00 0.000E+00  
 0.000E+00 1.752E-09

Total (all groups): 1.752E-09 neutrons/sec-cm\*\*3 .  
 Average Neutron Energy: 7.774E-02 MeV.

Neutron spectrum from u238 alphas on o 17 via the 0.00-MeV product level  
 0.000E+00 0.000E+00 0.000E+00 0.000E+00 0.000E+00 0.000E+00 2.275E-06 1.080E-05 4.728E-06  
 1.512E-07 0.000E+00

Total (all groups): 1.795E-05 neutrons/sec-cm\*\*3 .  
 Average Neutron Energy: 3.335E+00 MeV.

Neutron spectrum from u238 alphas on o 17 via the 1.63-MeV product level  
 0.000E+00 0.000E+00 0.000E+00 0.000E+00 0.000E+00 0.000E+00 0.000E+00 1.977E-05  
 3.148E-05 2.682E-06

Total (all groups): 5.393E-05 neutrons/sec-cm\*\*3 .  
 Average Neutron Energy: 1.818E+00 MeV.

---

Neutron spectrum from u235 alphas on o 18 via the 0.00-MeV product level  
 0.000E+00 0.000E+00 0.000E+00 0.000E+00 0.000E+00 0.000E+00 7.043E-06 5.353E-05  
 2.315E-05 2.393E-07

Total (all groups): 8.396E-05 neutrons/sec-cm\*\*3 .  
 Average Neutron Energy: 2.294E+00 MeV.

Neutron spectrum from u235 alphas on o 18 via the 0.35-MeV product level  
0.000E+00 0.000E+00 0.000E+00 0.000E+00 0.000E+00 0.000E+00 3.418E-07 3.344E-05  
3.123E-05 1.574E-06

Total (all groups): 6.659E-05 neutrons/sec-cm\*\*3  
Average Neutron Energy: 2.002E+00 MeV.

Neutron spectrum from u235 alphas on o 18 via the 1.75-MeV product level  
0.000E+00 0.000E+00 0.000E+00 0.000E+00 0.000E+00 0.000E+00 0.000E+00 0.000E+00  
2.922E-06 5.970E-06

Total (all groups): 8.893E-06 neutrons/sec-cm\*\*3  
Average Neutron Energy: 8.603E-01 MeV.

Neutron spectrum from u235 alphas on o 18 via the 2.79-MeV product level  
0.000E+00 0.000E+00 0.000E+00 0.000E+00 0.000E+00 0.000E+00 0.000E+00 0.000E+00  
0.000E+00 1.536E-06

Total (all groups): 1.536E-06 neutrons/sec-cm\*\*3  
Average Neutron Energy: 1.279E-01 MeV.

Neutron spectrum from u235 alphas on o 18 via the 2.79-MeV product level  
0.000E+00 0.000E+00 0.000E+00 0.000E+00 0.000E+00 0.000E+00 0.000E+00 0.000E+00  
0.000E+00 5.063E-07

Total (all groups): 5.063E-07 neutrons/sec-cm\*\*3  
Average Neutron Energy: 1.279E-01 MeV.

Neutron spectrum from u238 alphas on o 18 via the 0.00-MeV product level  
0.000E+00 0.000E+00 0.000E+00 0.000E+00 0.000E+00 0.000E+00 7.641E-06 2.146E-04  
1.255E-04 1.296E-06

Total (all groups): 3.490E-04 neutrons/sec-cm\*\*3  
Average Neutron Energy: 2.159E+00 MeV.

Neutron spectrum from u238 alphas on o 18 via the 0.35-MeV product level  
0.000E+00 0.000E+00 0.000E+00 0.000E+00 0.000E+00 0.000E+00 0.000E+00 1.032E-04  
1.548E-04 8.530E-06

Total (all groups): 2.665E-04 neutrons/sec-cm\*\*3  
Average Neutron Energy: 1.860E+00 MeV.

Neutron spectrum from u238 alphas on o 18 via the 1.75-MeV product level  
0.000E+00 0.000E+00 0.000E+00 0.000E+00 0.000E+00 0.000E+00 0.000E+00 0.000E+00  
3.615E-06 2.413E-05

Total (all groups): 2.775E-05 neutrons/sec-cm\*\*3  
Average Neutron Energy: 7.001E-01 MeV.

-----



Example Problem #4 (file: *outp*)

SOURCES 4C Calculation  
<<<<<<<<<>>>>>>>>>>>>>

Summary of Input  
=====

Title: Example 4 - WPu-Be Interface Problem

Interface problem input (idd = 2)  
Magnitudes and spectra computed (id = 2).  
Ascending energy structure for output (erg = 1).  
Number of elemental constituents on source side: 2  
Solid stopping cross-sections used (isg = 0) on source side.  
Maximum energy for alpha spectra: 6.500E+00 MeV.  
Minimum energy for alpha spectra: 1.000E-07 MeV.

Elemental Constituents on Source Side:

| Z-value | Atom Fraction |
|---------|---------------|
| 94      | 0.9998000264  |
| 95      | 0.0002000000  |

100 alpha energy groups used at interface.  
Number of source nuclides to be evaluated: 6

Source Nuclides:

| ZAID   | Atom Fraction |
|--------|---------------|
| 942380 | 5.000E-04     |
| 942390 | 9.233E-01     |
| 942400 | 6.500E-02     |
| 942410 | 1.000E-02     |
| 942420 | 1.000E-03     |
| 952410 | 2.000E-04     |

Target title: target is composed of Be  
Number of elemental constituents on target side: 1  
Solid stopping cross-sections used (isg = 0) on target side.

Elemental Constituents on Target Side:

| Z-value | Atom Fraction |
|---------|---------------|
| 4       | 1.0000000000  |

Number of neutron spectrum energy groups: 20  
Maximum neutron energy is 1.00000E+01 MeV.  
Minimum neutron energy is 0.00000E+00 MeV.

Energy Group Structure:

| Group | Upper-Bound | Lower-Bound |
|-------|-------------|-------------|
| 1     | 1.00000E+01 | 9.50000E+00 |
| 2     | 9.50000E+00 | 9.00000E+00 |
| 3     | 9.00000E+00 | 8.50000E+00 |
| 4     | 8.50000E+00 | 8.00000E+00 |
| 5     | 8.00000E+00 | 7.50000E+00 |
| 6     | 7.50000E+00 | 7.00000E+00 |

|    |            |            |
|----|------------|------------|
| 7  | 7.0000E+00 | 6.5000E+00 |
| 8  | 6.5000E+00 | 6.0000E+00 |
| 9  | 6.0000E+00 | 5.5000E+00 |
| 10 | 5.5000E+00 | 5.0000E+00 |
| 11 | 5.0000E+00 | 4.5000E+00 |
| 12 | 4.5000E+00 | 4.0000E+00 |
| 13 | 4.0000E+00 | 3.5000E+00 |
| 14 | 3.5000E+00 | 3.0000E+00 |
| 15 | 3.0000E+00 | 2.5000E+00 |
| 16 | 2.5000E+00 | 2.0000E+00 |
| 17 | 2.0000E+00 | 1.5000E+00 |
| 18 | 1.5000E+00 | 1.0000E+00 |
| 19 | 1.0000E+00 | 5.0000E-01 |
| 20 | 5.0000E-01 | 0.0000E+00 |

Number of target nuclides to be used: 1  
 4000 alpha energy groups used in target calculation.

Target Nuclides:

| ZAIID | Atom Fraction |
|-------|---------------|
| ----  | -----         |
| 40090 | 1.0000E+00    |

Summary of Output

Total (alpha,n) neutron source from all sources and targets: 2.35302E+02 n/sec-cm<sup>2</sup>.

Average (alpha,n) neutron energy: 4.66340E+00 MeV.

Normalized Neutron Energy Spectrum by Energy Group for All Sources:  
 (Note: group structure is independent of erg record!)

| Group | Contribution |
|-------|--------------|
| ----  | -----        |
| 1     | 9.08724E-03  |
| 2     | 2.08223E-02  |
| 3     | 2.73203E-02  |
| 4     | 3.83274E-02  |
| 5     | 5.65548E-02  |
| 6     | 6.38705E-02  |
| 7     | 6.41497E-02  |
| 8     | 5.49756E-02  |
| 9     | 3.58792E-02  |
| 10    | 2.43981E-02  |
| 11    | 4.61986E-02  |
| 12    | 5.98226E-02  |
| 13    | 8.03562E-02  |
| 14    | 1.10000E-01  |
| 15    | 1.27780E-01  |
| 16    | 9.04105E-02  |
| 17    | 3.38001E-02  |
| 18    | 2.30066E-02  |
| 19    | 2.51532E-02  |
| 20    | 6.39858E-03  |

Portion of Total Neutron Source Rate Accounted for in the Energy Spectrum: 99.8%.

Example Problem #4 (file: tape6)

SOURCES 4C Calculation  
 <<<<<<<<<>>>>>>>>>>>>

Neutron Source Magnitudes

Title: Example 4 - WPu-Be Interface Problem

1

Table I

(alpha,n) Neutron Production by Target and Alpha Energy

| target | target<br>atom frac. | alpha<br>energy | alphas/sec<br>/cm <sup>2</sup> | p(e)<br>neut/alpha | neuts/sec<br>/cm <sup>2</sup> |            |
|--------|----------------------|-----------------|--------------------------------|--------------------|-------------------------------|------------|
| +      | be 9                 | 1.0000E+00      | 0.033                          | 1.9603E+06         | 0.0000E+00                    | 0.0000E+00 |
|        |                      |                 | 0.098                          | 2.7754E+05         | 0.0000E+00                    | 0.0000E+00 |
|        |                      |                 | 0.163                          | 2.0218E+05         | 0.0000E+00                    | 0.0000E+00 |
|        |                      |                 | 0.228                          | 1.6769E+05         | 0.0000E+00                    | 0.0000E+00 |
|        |                      |                 | 0.293                          | 1.4755E+05         | 0.0000E+00                    | 0.0000E+00 |
|        |                      |                 | 0.358                          | 1.3451E+05         | 0.0000E+00                    | 0.0000E+00 |
|        |                      |                 | 0.423                          | 1.2565E+05         | 0.0000E+00                    | 0.0000E+00 |
|        |                      |                 | 0.488                          | 1.1950E+05         | 0.0000E+00                    | 0.0000E+00 |
|        |                      |                 | 0.553                          | 1.1523E+05         | 0.0000E+00                    | 0.0000E+00 |
|        |                      |                 | 0.618                          | 1.1235E+05         | 0.0000E+00                    | 0.0000E+00 |
|        |                      |                 | 0.683                          | 1.1051E+05         | 0.0000E+00                    | 0.0000E+00 |
|        |                      |                 | 0.748                          | 1.0948E+05         | 0.0000E+00                    | 0.0000E+00 |
|        |                      |                 | 0.813                          | 1.0910E+05         | 0.0000E+00                    | 0.0000E+00 |
|        |                      |                 | 0.878                          | 1.0924E+05         | 0.0000E+00                    | 0.0000E+00 |
|        |                      |                 | 0.943                          | 1.0979E+05         | 0.0000E+00                    | 0.0000E+00 |
|        |                      |                 | 1.008                          | 1.1068E+05         | 1.3351E-11                    | 1.4777E-06 |
|        |                      |                 | 1.073                          | 1.1186E+05         | 1.0388E-09                    | 1.1620E-04 |
|        |                      |                 | 1.138                          | 1.1326E+05         | 3.7388E-09                    | 4.2346E-04 |
|        |                      |                 | 1.203                          | 1.1485E+05         | 8.1722E-09                    | 9.3859E-04 |
|        |                      |                 | 1.268                          | 1.1659E+05         | 1.4399E-08                    | 1.6789E-03 |
|        |                      |                 | 1.333                          | 1.1846E+05         | 2.2482E-08                    | 2.6631E-03 |
|        |                      |                 | 1.398                          | 1.2042E+05         | 3.2482E-08                    | 3.9114E-03 |
|        |                      |                 | 1.463                          | 1.2246E+05         | 4.4463E-08                    | 5.4449E-03 |
|        |                      |                 | 1.528                          | 1.2456E+05         | 5.9190E-08                    | 7.3724E-03 |
|        |                      |                 | 1.593                          | 1.2670E+05         | 8.8810E-08                    | 1.1252E-02 |
|        |                      |                 | 1.658                          | 1.2888E+05         | 1.5884E-07                    | 2.0471E-02 |
|        |                      |                 | 1.723                          | 1.3107E+05         | 3.0681E-07                    | 4.0215E-02 |
|        |                      |                 | 1.788                          | 1.3329E+05         | 6.1381E-07                    | 8.1812E-02 |
|        |                      |                 | 1.853                          | 1.3550E+05         | 1.2215E-06                    | 1.6552E-01 |
|        |                      |                 | 1.918                          | 1.3772E+05         | 2.0781E-06                    | 2.8619E-01 |
|        |                      |                 | 1.983                          | 1.3993E+05         | 2.9520E-06                    | 4.1308E-01 |
|        |                      |                 | 2.048                          | 1.4213E+05         | 3.6605E-06                    | 5.2027E-01 |
|        |                      |                 | 2.113                          | 1.4432E+05         | 4.2595E-06                    | 6.1474E-01 |
|        |                      |                 | 2.178                          | 1.4649E+05         | 4.8080E-06                    | 7.0433E-01 |
|        |                      |                 | 2.243                          | 1.4865E+05         | 5.3977E-06                    | 8.0236E-01 |
|        |                      |                 | 2.308                          | 1.5078E+05         | 6.0085E-06                    | 9.0597E-01 |
|        |                      |                 | 2.373                          | 1.5290E+05         | 6.5728E-06                    | 1.0050E+00 |
|        |                      |                 | 2.438                          | 1.5499E+05         | 7.1391E-06                    | 1.1065E+00 |
|        |                      |                 | 2.503                          | 1.5706E+05         | 7.7353E-06                    | 1.2149E+00 |
|        |                      |                 | 2.568                          | 1.5910E+05         | 8.4016E-06                    | 1.3367E+00 |
|        |                      |                 | 2.633                          | 1.6112E+05         | 9.1124E-06                    | 1.4682E+00 |
|        |                      |                 | 2.698                          | 1.6312E+05         | 9.7956E-06                    | 1.5979E+00 |

|       |            |            |            |
|-------|------------|------------|------------|
| 2.763 | 1.6510E+05 | 1.0409E-05 | 1.7185E+00 |
| 2.828 | 1.6705E+05 | 1.0966E-05 | 1.8318E+00 |
| 2.893 | 1.6898E+05 | 1.1494E-05 | 1.9422E+00 |
| 2.958 | 1.7088E+05 | 1.1977E-05 | 2.0467E+00 |
| 3.023 | 1.7277E+05 | 1.2406E-05 | 2.1434E+00 |
| 3.088 | 1.7463E+05 | 1.2796E-05 | 2.2346E+00 |
| 3.153 | 1.7647E+05 | 1.3191E-05 | 2.3278E+00 |
| 3.218 | 1.7829E+05 | 1.3577E-05 | 2.4207E+00 |
| 3.283 | 1.8009E+05 | 1.3948E-05 | 2.5118E+00 |
| 3.348 | 1.8187E+05 | 1.4326E-05 | 2.6055E+00 |
| 3.413 | 1.8363E+05 | 1.4739E-05 | 2.7066E+00 |
| 3.478 | 1.8537E+05 | 1.5185E-05 | 2.8150E+00 |
| 3.543 | 1.8710E+05 | 1.5690E-05 | 2.9356E+00 |
| 3.608 | 1.8881E+05 | 1.6299E-05 | 3.0773E+00 |
| 3.673 | 1.9050E+05 | 1.7016E-05 | 3.2416E+00 |
| 3.738 | 1.9217E+05 | 1.7792E-05 | 3.4192E+00 |
| 3.803 | 1.9383E+05 | 1.8671E-05 | 3.6190E+00 |
| 3.868 | 1.9547E+05 | 1.9672E-05 | 3.8453E+00 |
| 3.933 | 1.9710E+05 | 2.0868E-05 | 4.1131E+00 |
| 3.998 | 1.9872E+05 | 2.2705E-05 | 4.5119E+00 |
| 4.063 | 2.0032E+05 | 2.5066E-05 | 5.0212E+00 |
| 4.128 | 2.0191E+05 | 2.7245E-05 | 5.5010E+00 |
| 4.193 | 2.0348E+05 | 2.9319E-05 | 5.9658E+00 |
| 4.258 | 2.0504E+05 | 3.1347E-05 | 6.4275E+00 |
| 4.323 | 2.0659E+05 | 3.3422E-05 | 6.9047E+00 |
| 4.388 | 2.0813E+05 | 3.5518E-05 | 7.3925E+00 |
| 4.453 | 2.0966E+05 | 3.7649E-05 | 7.8933E+00 |
| 4.518 | 2.1117E+05 | 3.9826E-05 | 8.4103E+00 |
| 4.583 | 2.1268E+05 | 4.1979E-05 | 8.9280E+00 |
| 4.648 | 2.1417E+05 | 4.4060E-05 | 9.4366E+00 |
| 4.713 | 2.1566E+05 | 4.6093E-05 | 9.9405E+00 |
| 4.778 | 2.1714E+05 | 4.8211E-05 | 1.0468E+01 |
| 4.843 | 2.1860E+05 | 5.0464E-05 | 1.1031E+01 |
| 4.908 | 2.2001E+05 | 5.2924E-05 | 1.1644E+01 |
| 4.973 | 2.2143E+05 | 5.5577E-05 | 1.2307E+01 |
| 5.038 | 2.2285E+05 | 5.8324E-05 | 1.2997E+01 |
| 5.103 | 2.1399E+05 | 6.1143E-05 | 1.3084E+01 |
| 5.168 | 8.2562E+04 | 6.3950E-05 | 5.2798E+00 |
| 5.233 | 2.5751E+04 | 6.6911E-05 | 1.7230E+00 |
| 5.298 | 2.5910E+04 | 7.0024E-05 | 1.8143E+00 |
| 5.363 | 2.6051E+04 | 7.3178E-05 | 1.9064E+00 |
| 5.428 | 2.5689E+04 | 7.6395E-05 | 1.9625E+00 |
| 5.493 | 1.1013E+04 | 7.9689E-05 | 8.7763E-01 |
| 5.558 | 1.9662E+00 | 8.3287E-05 | 1.6375E-04 |

Total: 2.3530E+02

+

Example Problem #4 (file: *tape7*)

SOURCES 4C Calculation  
<<<<<<<<<>>>>>>>>>>>>>>

Absolute Neutron Source Spectra  
~~~~~

Title: Example 4 - WPu-Be Interface Problem

Neutron Multigroup Structure (MeV)

0.000E+00 5.000E-01 1.000E+00 1.500E+00 2.000E+00 2.500E+00 3.000E+00 3.500E+00
4.000E+00 4.500E+00 5.000E+00 5.500E+00 6.000E+00 6.500E+00 7.000E+00 7.500E+00
8.000E+00 8.500E+00 9.000E+00 9.500E+00 1.000E+01

(a,n) neutrons from alphas on be 9 in target.

1.506E+00 5.919E+00 5.413E+00 7.953E+00 2.127E+01 3.007E+01 2.588E+01 1.891E+01
1.408E+01 1.087E+01 5.741E+00 8.442E+00 1.294E+01 1.509E+01 1.503E+01 1.331E+01
9.019E+00 6.429E+00 4.900E+00 2.138E+00

Total (all groups): 2.349E+02 neutrons/sec-cm².
Average Neutron Energy: 4.663E+00 MeV.

Total Neutron Spectrum

1.506E+00 5.919E+00 5.413E+00 7.953E+00 2.127E+01 3.007E+01 2.588E+01 1.891E+01
1.408E+01 1.087E+01 5.741E+00 8.442E+00 1.294E+01 1.509E+01 1.503E+01 1.331E+01
9.019E+00 6.429E+00 4.900E+00 2.138E+00

Total (all groups): 2.349E+02 neutrons/sec-cm².
Average Neutron Energy: 4.663E+00 MeV.

Example Problem #6 (file: *outp*)

SOURCES 4C Calculation
<<<<<<<<<<<<>>>>>>>>>>>>

Summary of Input =====

Title: Example 6 - Alpha Beam (5.5 MeV) on SiO₂
Beam problem input (icd = 3)
Magnitudes and spectra computed (id = 2)
Ascending energy structure for output (erg = 1)
Number of elemental constituents: 2
Solid stopping cross-sections used (isg = 0)

Elemental Constituents:

Z-value	Atom Fraction
8	0.6666669846
14	0.3333329856

Number of neutron spectrum energy groups: 22
Maximum neutron energy is 1.000E+01 MeV.
Minimum neutron energy is 0.000E+00 MeV.

Energy Group Structure:

Group	Upper-Bound	Lower-Bound
1	1.000E+01	7.000E+00
2	7.000E+00	6.000E+00
3	6.000E+00	5.500E+00
4	5.500E+00	5.000E+00
5	5.000E+00	4.500E+00
6	4.500E+00	4.000E+00
7	4.000E+00	3.500E+00
8	3.500E+00	3.250E+00
9	3.250E+00	3.000E+00
10	3.000E+00	2.750E+00
11	2.750E+00	2.500E+00
12	2.500E+00	2.250E+00
13	2.250E+00	2.000E+00
14	2.000E+00	1.750E+00
15	1.750E+00	1.500E+00
16	1.500E+00	1.250E+00
17	1.250E+00	1.000E+00
18	1.000E+00	7.500E-01
19	7.500E-01	5.000E-01
20	5.000E-01	2.500E-01
21	2.500E-01	1.000E-01
22	1.000E-01	0.000E+00

Alpha beam energy is 5.500E+00 Mev.

Number of target nuclides to be used: 4
4000 Alpha energy groups used.

Target Nuclides:

ZAID	Atom Fraction
80170	2.530E-04

80180	1.333E-03
140290	1.557E-02
140300	1.033E-02

Summary of Output

Total (alpha,n) neutron source from all sources and targets: 3.261E+05 n/sec-microamp.

Average (alpha,n) neutron energy: 1.965E+00 MeV.

Normalized Neutron Energy Spectrum by Energy Group for All Sources:

(Note: descending group structure is independent of erg record.)

Group	Contribution
-----	-----
1	0.000E+00
2	0.000E+00
3	9.134E-05
4	4.811E-04
5	8.194E-04
6	7.903E-03
7	3.521E-02
8	3.882E-02
9	5.565E-02
10	7.192E-02
11	7.803E-02
12	7.718E-02
13	6.985E-02
14	6.158E-02
15	4.588E-02
16	4.422E-02
17	7.885E-02
18	1.131E-01
19	1.163E-01
20	7.256E-02
21	2.385E-02
22	7.673E-03

Portion of Total Neutron Source Rate Accounted for in the Total Energy Spectrum: 100.0%.

Example Problem #6 (file: tape6)

SOURCES 4C Calculation
 <<<<<<<<<<>>>>>>>>>>>>

Neutron Source Magnitudes
 ~~~~~

Title: Example 6 - Alpha Beam (5.5 MeV) on SiO2

1 Table I  
 =====

(alpha,n) Neutron Production by Target Per Source Alpha

|   | target               | target<br>atom frac. | alpha<br>source | alpha<br>energy | alphas/sec<br>/microamp | p(e)<br>neut/alpha | neuts/sec<br>/microamp |
|---|----------------------|----------------------|-----------------|-----------------|-------------------------|--------------------|------------------------|
| + | o 17                 | 2.5300E-04           | beam            | 5.500           | 3.1209E+12              | 3.2813E-09         | 1.0240E+04             |
|   | o 18                 | 1.3330E-03           | beam            | 5.500           | 3.1209E+12              | 3.7792E-08         | 1.1795E+05             |
|   | si 29                | 1.5567E-02           | beam            | 5.500           | 3.1209E+12              | 4.2853E-08         | 1.3374E+05             |
|   | si 30                | 1.0333E-02           | beam            | 5.500           | 3.1209E+12              | 2.0548E-08         | 6.4127E+04             |
| + | Total (all targets): |                      |                 |                 |                         |                    | 3.2605E+05             |



Example Problem #6 (file: tape7)

SOURCES 4C Calculation  
<<<<<<<<<>>>>>>>>>>>

Absolute Neutron Source Spectra

Title: Example 6 - Alpha Beam (5.5 MeV) on SiO2

Neutron Multigroup Structure (MeV)

|           |           |           |           |           |           |           |           |
|-----------|-----------|-----------|-----------|-----------|-----------|-----------|-----------|
| 0.000E+00 | 1.000E-01 | 2.500E-01 | 5.000E-01 | 7.500E-01 | 1.000E+00 | 1.250E+00 | 1.500E+00 |
| 1.750E+00 | 2.000E+00 | 2.250E+00 | 2.500E+00 | 2.750E+00 | 3.000E+00 | 3.250E+00 | 3.500E+00 |
| 4.000E+00 | 4.500E+00 | 5.000E+00 | 5.500E+00 | 6.000E+00 | 7.000E+00 | 1.000E+01 |           |

-----  
(a,n) neutrons/sec-microamp 5.500 mev a on o 17 in target  
3.822E+01 1.201E+02 3.538E+02 3.603E+02 2.687E+02 2.388E+02 3.470E+02 6.080E+02  
7.442E+02 8.887E+02 1.039E+03 1.007E+03 8.636E+02 7.900E+02 6.879E+02 9.911E+02  
4.388E+02 2.672E+02 1.569E+02 2.978E+01 0.000E+00 0.000E+00  
Total (all groups): 1.024E+04 neutrons/sec-microamp.  
Average Neutron Energy: 2.522E+00 MeV.

(a,n) neutrons/sec-microamp 5.500 mev a on o 18 in target  
5.850E+02 1.438E+03 2.516E+03 2.911E+03 3.247E+03 3.950E+03 5.202E+03 6.951E+03  
9.322E+03 1.171E+04 1.337E+04 1.372E+04 1.293E+04 1.056E+04 8.074E+03 9.316E+03  
2.138E+03 2.609E-02 1.532E-02 2.908E-03 0.000E+00 0.000E+00  
Total (all groups): 1.179E+05 neutrons/sec-microamp.  
Average Neutron Energy: 2.385E+00 MeV.

(a,n) neutrons/sec-microamp 5.500 mev a on si 29 in target  
5.313E+02 2.912E+03 1.251E+04 1.980E+04 1.789E+04 8.670E+03 2.317E+03 5.933E+03  
1.001E+04 1.018E+04 1.076E+04 1.071E+04 9.658E+03 6.793E+03 3.895E+03 1.173E+03  
1.813E-02 2.212E-07 1.299E-07 2.466E-08 0.000E+00 0.000E+00  
Total (all groups): 1.337E+05 neutrons/sec-microamp.  
Average Neutron Energy: 1.993E+00 MeV.

(a,n) neutrons/sec-microamp 5.500 mev a on si 30 in target  
1.347E+03 3.308E+03 8.277E+03 1.485E+04 1.548E+04 1.285E+04 6.552E+03 1.469E+03  
7.487E-02 7.612E-02 8.046E-02 8.010E-02 7.221E-02 5.079E-02 2.912E-02 8.770E-03  
1.355E-07 1.654E-12 9.710E-13 1.844E-13 0.000E+00 0.000E+00  
Total (all groups): 6.413E+04 neutrons/sec-microamp.  
Average Neutron Energy: 1.761E+00 MeV.

-----  
Grand total (alpha,n) neutron spectrum, all targets, all sources  
2.502E+03 7.777E+03 2.366E+04 3.792E+04 3.688E+04 2.571E+04 1.442E+04 1.496E+04  
2.008E+04 2.278E+04 2.516E+04 2.544E+04 2.345E+04 1.815E+04 1.266E+04 1.148E+04  
2.577E+03 2.672E+02 1.569E+02 2.978E+01 0.000E+00 0.000E+00  
Total (all groups): 3.260E+05 neutrons/sec-microamp.  
Average Neutron Energy: 1.965E+00 MeV.

## Example Problem #6 (file: *tape9*)

SOURCES 4C Calculation  
 <<<<<<<<<<>>>>>>>>

### Neutron Source Spectra by Nuclide Energy Level

Title: Example 6 - Alpha Beam (5.5 MeV) on SiO2

Neutron Multigroup Structure (MeV)

0.000E+00 1.000E-01 2.500E-01 5.000E-01 7.500E-01 1.000E+00 1.250E+00 1.500E+00  
 1.750E+00 2.000E+00 2.250E+00 2.500E+00 2.750E+00 3.000E+00 3.250E+00 3.500E+00  
 4.000E+00 4.500E+00 5.000E+00 5.500E+00 6.000E+00 7.000E+00 1.000E+01

Neutron spectrum from 5.50 MeV alphas on o 17 via the 0.00-MeV product level

0.000E+00 0.000E+00 2.978E+01 1.569E+02 2.672E+02 4.260E+02 4.990E+02 2.171E+02  
 1.847E+02 1.265E+02 7.294E+01 4.086E+01 1.717E+01 7.291E+00 7.421E-01 6.503E-02  
 0.000E+00 0.000E+00 0.000E+00 0.000E+00 0.000E+00 0.000E+00 0.000E+00

Total (all groups): 2.046E+03 neutrons/sec-microamp.  
 Average Neutron Energy: 3.884E+00 MeV.

Neutron spectrum from 5.50 MeV alphas on o 17 via the 1.63-MeV product level

0.000E+00 0.000E+00 0.000E+00 0.000E+00 0.000E+00 1.283E+01 4.921E+02 4.707E+02  
 6.053E+02 7.372E+02 9.338E+02 9.983E+02 8.716E+02 7.369E+02 6.073E+02 3.469E+02  
 1.964E+02 8.404E+01 4.867E+01 1.092E+01 6.001E-01 8.262E-02

Total (all groups): 7.154E+03 neutrons/sec-microamp.  
 Average Neutron Energy: 2.422E+00 MeV.

Neutron spectrum from 5.50 MeV alphas on o 17 via the 4.25-MeV product level

0.000E+00 0.000E+00 0.000E+00 0.000E+00 0.000E+00 0.000E+00 0.000E+00 0.000E+00  
 0.000E+00 0.000E+00 0.000E+00 0.000E+00 0.000E+00 0.000E+00 0.000E+00 0.000E+00  
 4.240E+01 1.846E+02 3.116E+02 3.429E+02 1.133E+02 3.016E+01

Total (all groups): 1.025E+03 neutrons/sec-microamp.  
 Average Neutron Energy: 5.362E-01 MeV.

Neutron spectrum from 5.50 MeV alphas on o 17 via the 4.97-MeV product level

0.000E+00 0.000E+00 0.000E+00 0.000E+00 0.000E+00 0.000E+00 0.000E+00 0.000E+00  
 0.000E+00 0.000E+00 0.000E+00 0.000E+00 0.000E+00 0.000E+00 0.000E+00 0.000E+00  
 0.000E+00 0.000E+00 0.000E+00 0.000E+00 6.171E+00 7.983E+00

Total (all groups): 1.415E+01 neutrons/sec-microamp.  
 Average Neutron Energy: 9.355E-02 MeV.

Neutron spectrum from 5.50 MeV alphas on o 18 via the 0.00-MeV product level

0.000E+00 0.000E+00 2.978E+01 1.569E+02 2.672E+02 2.437E+03 6.435E+03 5.097E+03  
 6.280E+03 7.238E+03 7.053E+03 6.253E+03 4.737E+03 3.345E+03 1.935E+03 1.088E+03  
 4.876E+02 5.727E+01 9.773E+00 2.367E+00 6.605E-02 0.000E+00

Total (all groups): 5.086E+04 neutrons/sec-microamp.  
 Average Neutron Energy: 2.817E+00 MeV.

Neutron spectrum from 5.50 MeV alphas on o 18 via the 0.35-MeV product level

0.000E+00 0.000E+00 0.000E+00 0.000E+00 0.000E+00 1.400E+02 3.872E+03 3.665E+03  
 5.074E+03 6.555E+03 7.610E+03 7.493E+03 6.637E+03 5.058E+03 3.470E+03 1.903E+03  
 1.041E+03 4.832E+02 1.042E+02 1.578E+01 1.292E+00 1.166E-01

Total (all groups): 4.597E+04 neutrons/sec-microamp.

Average Neutron Energy: 2.509E+00 MeV.

Neutron spectrum from 5.50 MeV alphas on o 18 via the 1.75-MeV product level  
0.000E+00 0.000E+00 0.000E+00 0.000E+00 0.000E+00 0.000E+00 0.000E+00 0.000E+00  
0.000E+00 0.000E+00 6.746E+01 6.589E+02 1.222E+03 1.663E+03 2.154E+03 2.369E+03  
1.752E+03 1.410E+03 9.684E+02 6.335E+02 1.586E+02 3.654E+01

Total (all groups): 1.207E+04 neutrons/sec-microamp.  
Average Neutron Energy: 1.397E+00 MeV.

Neutron spectrum from 5.50 MeV alphas on o 18 via the 2.79-MeV product level  
0.000E+00 0.000E+00 0.000E+00 0.000E+00 0.000E+00 0.000E+00 0.000E+00 0.000E+00  
0.000E+00 0.000E+00 0.000E+00 0.000E+00 0.000E+00 0.000E+00 0.000E+00 1.232E+02  
5.985E+02 1.046E+03 1.491E+03 1.559E+03 9.184E+02 3.482E+02

Total (all groups): 6.071E+03 neutrons/sec-microamp.  
Average Neutron Energy: 5.627E-01 MeV.

Neutron spectrum from 5.50 MeV alphas on o 18 via the 2.79-MeV product level  
0.000E+00 0.000E+00 0.000E+00 0.000E+00 0.000E+00 0.000E+00 0.000E+00 0.000E+00  
0.000E+00 0.000E+00 0.000E+00 0.000E+00 0.000E+00 0.000E+00 0.000E+00 6.528E+01  
3.094E+02 5.195E+02 6.980E+02 6.325E+02 3.292E+02 1.162E+02

Total (all groups): 2.670E+03 neutrons/sec-microamp.  
Average Neutron Energy: 6.061E-01 MeV.

Neutron spectrum from 5.50 MeV alphas on o 18 via the 3.66-MeV product level  
0.000E+00 0.000E+00 0.000E+00 0.000E+00 0.000E+00 0.000E+00 0.000E+00 0.000E+00  
0.000E+00 0.000E+00 0.000E+00 0.000E+00 0.000E+00 0.000E+00 0.000E+00 0.000E+00  
0.000E+00 0.000E+00 0.000E+00 2.647E+01 1.501E+02 1.221E+02

Total (all groups): 2.987E+02 neutrons/sec-microamp.  
Average Neutron Energy: 1.303E-01 MeV.

Neutron spectrum from 5.50 MeV alphas on si 29 via the 0.00-MeV product level  
0.000E+00 0.000E+00 2.978E+01 1.569E+02 2.672E+02 2.437E+03 7.608E+03 8.992E+03  
1.307E+04 1.690E+04 1.777E+04 1.701E+04 1.492E+04 1.336E+04 7.867E+03 2.668E+03  
7.294E+02 1.509E+02 5.791E+01 2.923E+01 7.119E+00 1.266E+00

Total (all groups): 7.111E+04 neutrons/sec-microamp.  
Average Neutron Energy: 2.594E+00 MeV.

Neutron spectrum from 5.50 MeV alphas on si 29 via the 2.24-MeV product level  
0.000E+00 0.000E+00 0.000E+00 0.000E+00 0.000E+00 1.400E+02 3.872E+03 3.665E+03  
5.074E+03 6.555E+03 7.610E+03 7.493E+03 6.637E+03 5.058E+03 3.470E+03 2.641E+03  
9.469E+03 1.828E+04 1.985E+04 1.250E+04 2.906E+03 5.302E+02

Total (all groups): 6.263E+04 neutrons/sec-microamp.  
Average Neutron Energy: 1.527E+00 MeV.

Neutron spectrum from 5.50 MeV alphas on si 29 via the 3.78-MeV product level  
0.000E+00 0.000E+00 0.000E+00 0.000E+00 0.000E+00 0.000E+00 0.000E+00 0.000E+00  
0.000E+00 0.000E+00 6.746E+01 6.589E+02 1.222E+03 1.663E+03 2.154E+03 2.369E+03  
1.752E+03 1.410E+03 9.684E+02 6.335E+02 1.586E+02 3.654E+01

Total (all groups): 0.000E+00 neutrons/sec-microamp.  
Average Neutron Energy: 1.397E+00 MeV.

Neutron spectrum from 5.50 MeV alphas on si 30 via the 0.00-MeV product level  
0.000E+00 0.000E+00 2.978E+01 1.569E+02 2.672E+02 2.437E+03 7.608E+03 8.992E+03  
1.307E+04 1.690E+04 1.777E+04 1.701E+04 1.492E+04 1.336E+04 9.336E+03 9.220E+03  
1.358E+04 1.563E+04 1.413E+04 6.336E+03 2.426E+03 1.108E+03

Total (all groups): 6.025E+04 neutrons/sec-microamp.  
Average Neutron Energy: 2.022E+00 MeV.

Neutron spectrum from 5.50 MeV alphas on si 30 via the 0.84-MeV product level  
0.000E+00 0.000E+00 0.000E+00 0.000E+00 0.000E+00 1.400E+02 3.872E+03 3.665E+03  
5.074E+03 6.555E+03 7.610E+03 7.493E+03 6.637E+03 5.058E+03 3.470E+03 2.641E+03  
9.469E+03 1.828E+04 2.063E+04 1.447E+04 3.795E+03 7.707E+02  
Total (all groups): 3.874E+03 neutrons/sec-microamp.  
Average Neutron Energy: 1.489E+00 MeV.

Neutron spectrum from 5.50 MeV alphas on si 30 via the 1.97-MeV product level  
0.000E+00 0.000E+00 0.000E+00 0.000E+00 0.000E+00 0.000E+00 0.000E+00 0.000E+00  
0.000E+00 0.000E+00 6.746E+01 6.589E+02 1.222E+03 1.663E+03 2.154E+03 2.369E+03  
1.752E+03 1.410E+03 9.684E+02 6.335E+02 1.586E+02 3.654E+01  
Total (all groups): 0.000E+00 neutrons/sec-microamp.  
Average Neutron Energy: 1.397E+00 MeV.

Example Problem #7 (file: *outp*)

SOURCES 4C Calculation  
<<<<<<<<<<<<<<<<<<>>>>>>>>>>>>>>>

Summary of Input  
=====

Title: Three Region Test Problem #1 (WPu-Al-Be)

Three region problem input (idd = 4)  
Magnitudes and spectra computed.

400 alpha energy groups used at each interface.  
Maximum energy for alpha spectra: 6.500E+00 MeV.  
Minimum energy for alpha spectra: 1.000E-07 MeV.

Number of neutron spectrum energy groups: 20  
Maximum neutron energy is 1.00000E+01 MeV.  
Minimum neutron energy is 0.00000E+00 MeV.

Neutron Energy Group Structure:

| Group | Upper-Bound | Lower-Bound |
|-------|-------------|-------------|
| 1     | 1.00000E+01 | 9.50000E+00 |
| 2     | 9.50000E+00 | 9.00000E+00 |
| 3     | 9.00000E+00 | 8.50000E+00 |
| 4     | 8.50000E+00 | 8.00000E+00 |
| 5     | 8.00000E+00 | 7.50000E+00 |
| 6     | 7.50000E+00 | 7.00000E+00 |
| 7     | 7.00000E+00 | 6.50000E+00 |
| 8     | 6.50000E+00 | 6.00000E+00 |
| 9     | 6.00000E+00 | 5.50000E+00 |
| 10    | 5.50000E+00 | 5.00000E+00 |
| 11    | 5.00000E+00 | 4.50000E+00 |
| 12    | 4.50000E+00 | 4.00000E+00 |
| 13    | 4.00000E+00 | 3.50000E+00 |
| 14    | 3.50000E+00 | 3.00000E+00 |
| 15    | 3.00000E+00 | 2.50000E+00 |
| 16    | 2.50000E+00 | 2.00000E+00 |
| 17    | 2.00000E+00 | 1.50000E+00 |
| 18    | 1.50000E+00 | 1.00000E+00 |
| 19    | 1.00000E+00 | 5.00000E-01 |
| 20    | 5.00000E-01 | 0.00000E+00 |

Number of angular groups: 40

Angular Group Structure:

| Group | Upper-Bound | Lower-Bound |
|-------|-------------|-------------|
| 1     | 3.92699E-02 | 0.00000E+00 |
| 2     | 7.85398E-02 | 3.92699E-02 |
| 3     | 1.17810E-01 | 7.85398E-02 |
| 4     | 1.57080E-01 | 1.17810E-01 |
| 5     | 1.96350E-01 | 1.57080E-01 |
| 6     | 2.35619E-01 | 1.96350E-01 |
| 7     | 2.74889E-01 | 2.35619E-01 |
| 8     | 3.14159E-01 | 2.74889E-01 |
| 9     | 3.53429E-01 | 3.14159E-01 |
| 10    | 3.92699E-01 | 3.53429E-01 |
| 11    | 4.31969E-01 | 3.92699E-01 |
| 12    | 4.71239E-01 | 4.31969E-01 |

|    |             |             |
|----|-------------|-------------|
| 13 | 5.10509E-01 | 4.71239E-01 |
| 14 | 5.49779E-01 | 5.10509E-01 |
| 15 | 5.89049E-01 | 5.49779E-01 |
| 16 | 6.28319E-01 | 5.89049E-01 |
| 17 | 6.67589E-01 | 6.28319E-01 |
| 18 | 7.06859E-01 | 6.67589E-01 |
| 19 | 7.46128E-01 | 7.06859E-01 |
| 20 | 7.85398E-01 | 7.46128E-01 |
| 21 | 8.24668E-01 | 7.85398E-01 |
| 22 | 8.63938E-01 | 8.24668E-01 |
| 23 | 9.03208E-01 | 8.63938E-01 |
| 24 | 9.42478E-01 | 9.03208E-01 |
| 25 | 9.81748E-01 | 9.42478E-01 |
| 26 | 1.02102E+00 | 9.81748E-01 |
| 27 | 1.06029E+00 | 1.02102E+00 |
| 28 | 1.09956E+00 | 1.06029E+00 |
| 29 | 1.13883E+00 | 1.09956E+00 |
| 30 | 1.17810E+00 | 1.13883E+00 |
| 31 | 1.21737E+00 | 1.17810E+00 |
| 32 | 1.25664E+00 | 1.21737E+00 |
| 33 | 1.29591E+00 | 1.25664E+00 |
| 34 | 1.33518E+00 | 1.29591E+00 |
| 35 | 1.37445E+00 | 1.33518E+00 |
| 36 | 1.41372E+00 | 1.37445E+00 |
| 37 | 1.45299E+00 | 1.41372E+00 |
| 38 | 1.49226E+00 | 1.45299E+00 |
| 39 | 1.53153E+00 | 1.49226E+00 |
| 40 | 1.57080E+00 | 1.53153E+00 |

Region A Title: WPU region

Number of elemental constituents in region A: 2  
 Solid stopping cross-sections used (isga= 0) in region A.  
 Elemental Constituents in Region A:

| Z-value | Atom Fraction |
|---------|---------------|
| -----   | -----         |
| 94      | 0.9998000264  |
| 95      | 0.0002000000  |

Number of source nuclides to be evaluated: 6

Source Nuclides in Region A:

| ZAID   | Atom Fraction |
|--------|---------------|
| ----   | -----         |
| 942380 | 5.000E-04     |
| 942390 | 9.233E-01     |
| 942400 | 6.500E-02     |
| 942410 | 1.000E-02     |
| 942420 | 1.000E-03     |
| 952410 | 2.000E-04     |

Region B Title: Al interface

Number of elemental constituents in region B: 1  
 Solid stopping cross-sections used (isgb= 0) in region B.  
 Material B atom density: 1.50000E-01 atoms/b-cm.  
 Interface region thickness: 1.00000E-05 cm.

Elemental Constituents in Region B:

| Z-value | Atom Fraction |
|---------|---------------|
| -----   | -----         |
| 13      | 1.0000000000  |

Number of target nuclides in region B: 1

Target Nuclides in Region B:

| ZAID   | Atom Fraction |
|--------|---------------|
| ----   | -----         |
| 130270 | 1.000E+00     |

Region C Title: Be reflector

Number of elemental constituents in region C: 1  
Solid stopping cross-sections used (isgc= 0) in region C.

Elemental Constituents in Region C:

| Z-value | Atom Fraction |
|---------|---------------|
| -----   | -----         |
| 4       | 1.0000000000  |

Number of target nuclides in region C: 1

Target Nuclides in Region C:

| ZAID  | Atom Fraction |
|-------|---------------|
| ----  | -----         |
| 40090 | 1.000E+00     |

Summary of Output

=====

Total (alpha,n) neutron source from all sources and targets: 2.23228E+02 n/sec-cm<sup>2</sup>.

Average (alpha,n) neutron energy: 4.64321E+00 MeV.

Normalized Neutron Energy Spectrum by Energy Group for All Sources:

(Note: group structure is independent of erg record!)

| Group | Contribution |
|-------|--------------|
| ----- | -----        |
| 1     | 8.73540E-03  |
| 2     | 2.03801E-02  |
| 3     | 2.69604E-02  |
| 4     | 3.82669E-02  |
| 5     | 5.70538E-02  |
| 6     | 6.46088E-02  |
| 7     | 6.49235E-02  |
| 8     | 5.59476E-02  |
| 9     | 3.57871E-02  |
| 10    | 2.28495E-02  |
| 11    | 4.46153E-02  |
| 12    | 5.84809E-02  |
| 13    | 7.95498E-02  |
| 14    | 1.10205E-01  |
| 15    | 1.30674E-01  |
| 16    | 9.29785E-02  |
| 17    | 3.41897E-02  |
| 18    | 2.25102E-02  |
| 19    | 2.48078E-02  |
| 20    | 6.47559E-03  |

Example Problem #7 (file: tape7)

SOURCES 4C Calculation  
<<<<<<<<<<<<>>>>>>>>>>>>

Absolute Neutron Source Spectra  
~~~~~

Title: Three Region Test Problem #1 (WPu-Al-Be)

Neutron Multigroup Structure (MeV)

1.000E+01 9.500E+00 9.000E+00 8.500E+00 8.000E+00 7.500E+00 7.000E+00 6.500E+00
6.000E+00 5.500E+00 5.000E+00 4.500E+00 4.000E+00 3.500E+00 3.000E+00 2.500E+00
2.000E+00 1.500E+00 1.000E+00 5.000E-01 0.000E+00

=====
Title: Alphas at interface ab using region B materials for neutron production

Neutron Spectrum (neuts/cm²-sec)

0.000E+00 0.000E+00 0.000E+00 0.000E+00 0.000E+00 0.000E+00 0.000E+00 0.000E+00
0.000E+00 0.000E+00 0.000E+00 0.000E+00 0.000E+00 0.000E+00 1.434E-06 4.959E-03
7.191E-02 1.859E-01 2.213E-01 1.115E-01

Total (all groups): 5.956E-01 neutrons/sec-cm².
Average Neutron Energy: 9.431E-01 MeV.

Total Neutron Spectrum

0.000E+00 0.000E+00 0.000E+00 0.000E+00 0.000E+00 0.000E+00 0.000E+00 0.000E+00
0.000E+00 0.000E+00 0.000E+00 0.000E+00 0.000E+00 0.000E+00 1.434E-06 4.959E-03
7.191E-02 1.859E-01 2.213E-01 1.115E-01

Total (all groups): 5.956E-01 neutrons/sec-cm².
Average Neutron Energy: 9.431E-01 MeV.

=====
Title: Alphas at interface bc using region B materials for neutron production

Neutron Spectrum (neuts/cm²-sec)

0.000E+00 0.000E+00 0.000E+00 0.000E+00 0.000E+00 0.000E+00 0.000E+00 0.000E+00
0.000E+00 0.000E+00 0.000E+00 0.000E+00 0.000E+00 0.000E+00 5.292E-08 3.347E-03
5.912E-02 1.643E-01 2.005E-01 9.813E-02

Total (all groups): 5.254E-01 neutrons/sec-cm².
Average Neutron Energy: 9.322E-01 MeV.

Total Neutron Spectrum

0.000E+00 0.000E+00 0.000E+00 0.000E+00 0.000E+00 0.000E+00 0.000E+00 0.000E+00
0.000E+00 0.000E+00 0.000E+00 0.000E+00 0.000E+00 0.000E+00 5.292E-08 3.347E-03

5.912E-02 1.643E-01 2.005E-01 9.813E-02

Total (all groups): 5.254E-01 neutrons/sec-cm².
Average Neutron Energy: 9.380E-01 MeV.

=====
Title: Alphas at interface bc using region C materials for neutron production

Neutron Spectrum (neuts/cm²-sec)

1.950E+00 4.549E+00 6.018E+00 8.542E+00 1.274E+01 1.442E+01 1.449E+01 1.249E+01
7.989E+00 5.101E+00 9.959E+00 1.305E+01 1.776E+01 2.460E+01 2.917E+01 2.075E+01
7.619E+00 5.003E+00 5.517E+00 1.432E+00

Total (all groups): 2.232E+02 neutrons/sec-cm².
Average Neutron Energy: 4.655E+00 MeV.

Total Neutron Spectrum

1.950E+00 4.549E+00 6.018E+00 8.542E+00 1.274E+01 1.442E+01 1.449E+01 1.249E+01
7.989E+00 5.101E+00 9.959E+00 1.305E+01 1.776E+01 2.460E+01 2.917E+01 2.075E+01
7.619E+00 5.003E+00 5.517E+00 1.432E+00

Total (all groups): 2.232E+02 neutrons/sec-cm².
Average Neutron Energy: 4.636E+00 MeV.

=====
Title: Total neutron production from all interfaces

Total Neutron Spectrum

1.950E+00 4.549E+00 6.018E+00 8.542E+00 1.274E+01 1.442E+01 1.449E+01 1.249E+01
7.989E+00 5.101E+00 9.959E+00 1.305E+01 1.776E+01 2.460E+01 2.917E+01 2.076E+01
7.632E+00 5.025E+00 5.538E+00 1.446E+00

Total (all groups): 2.232E+02 neutrons/sec-cm².
Average Neutron Energy: 4.643E+00 MeV.

11	2.87979E-01	2.61799E-01
12	3.14159E-01	2.87979E-01
13	3.40339E-01	3.14159E-01
14	3.66519E-01	3.40339E-01
15	3.92699E-01	3.66519E-01
16	4.18879E-01	3.92699E-01
17	4.45059E-01	4.18879E-01
18	4.71239E-01	4.45059E-01
19	4.97419E-01	4.71239E-01
20	5.23599E-01	4.97419E-01
21	5.49779E-01	5.23599E-01
22	5.75959E-01	5.49779E-01
23	6.02139E-01	5.75959E-01
24	6.28318E-01	6.02139E-01
25	6.54498E-01	6.28318E-01
26	6.80678E-01	6.54498E-01
27	7.06858E-01	6.80678E-01
28	7.33038E-01	7.06858E-01
29	7.59218E-01	7.33038E-01
30	7.85398E-01	7.59218E-01
31	8.11578E-01	7.85398E-01
32	8.37758E-01	8.11578E-01
33	8.63938E-01	8.37758E-01
34	8.90118E-01	8.63938E-01
35	9.16297E-01	8.90118E-01
36	9.42477E-01	9.16297E-01
37	9.68657E-01	9.42477E-01
38	9.94837E-01	9.68657E-01
39	1.02102E+00	9.94837E-01
40	1.04720E+00	1.02102E+00
41	1.07338E+00	1.04720E+00
42	1.09956E+00	1.07338E+00
43	1.12574E+00	1.09956E+00
44	1.15192E+00	1.12574E+00
45	1.17810E+00	1.15192E+00
46	1.20428E+00	1.17810E+00
47	1.23046E+00	1.20428E+00
48	1.25664E+00	1.23046E+00
49	1.28282E+00	1.25664E+00
50	1.30900E+00	1.28282E+00
51	1.33518E+00	1.30900E+00
52	1.36136E+00	1.33518E+00
53	1.38754E+00	1.36136E+00
54	1.41372E+00	1.38754E+00
55	1.43990E+00	1.41372E+00
56	1.46608E+00	1.43990E+00
57	1.49226E+00	1.46608E+00
58	1.51844E+00	1.49226E+00
59	1.54462E+00	1.51844E+00
60	1.57080E+00	1.54462E+00

Region A Title: Pure Am-241 in region A

Number of elemental constituents in region A: 1
 Solid stopping cross-sections used (isga= 0) in region A.
 Elemental Constituents in Region A:

Z-value	Atom Fraction
95	1.0000000000

Number of source nuclides to be evaluated: 1

Source Nuclides in Region A:

ZAID	Atom Fraction
------	---------------

952410 1.000E+00

Region B Title: CO2 gas in region B

Number of elemental constituents in region B: 2
Gas stopping cross-sections used (isgb= 1) in region B.
Material B atom density: 7.00000E-05 atoms/b-cm.
Interface region thickness: 3.00000E+00 cm.

Elemental Constituents in Region B:

Z-value	Atom Fraction
-----	-----
6	0.3330000043
8	0.6669999957

Number of target nuclides in region B: 3

Target Nuclides in Region B:

ZAID	Atom Fraction
----	-----
60130	7.333E-03
80170	2.667E-04
80180	1.333E-03

Region C Title: AlB2 shield in region C

Number of elemental constituents in region C: 2
Solid stopping cross-sections used (isgc= 0) in region C.

Elemental Constituents in Region C:

Z-value	Atom Fraction
-----	-----
13	0.3333300054
5	0.6666700244

Number of target nuclides in region C: 3

Target Nuclides in Region C:

ZAID	Atom Fraction
----	-----
50100	1.327E-01
50110	5.340E-01
130270	3.333E-01

Summary of Output

=====

Total (alpha,n) neutron source from all sources and targets: 1.71845E+01 n/sec-cm².

Average (alpha,n) neutron energy: 3.49170E+00 MeV.

Normalized Neutron Energy Spectrum by Energy Group for All Sources:
(Note: group structure is independent of erg record!)

Group	Contribution
-----	-----
1	0.00000E+00

2	0.00000E+00
3	0.00000E+00
4	0.00000E+00
5	3.91376E-10
6	2.60059E-03
7	1.25549E-02
8	2.07458E-02
9	2.93334E-02
10	6.72478E-02
11	1.02704E-01
12	1.47075E-01
13	1.51736E-01
14	1.12476E-01
15	8.51107E-02
16	1.06183E-01
17	8.28277E-02
18	4.25197E-02
19	1.79385E-02
20	1.89478E-02

Example Problem #8 (file: tape7)

SOURCES 4C Calculation
 <<<<<<<<<<<>>>>>>>>>>>>>

Absolute Neutron Source Spectra
 ~~~~~

Title: Example 8 - Am-CO2-ALB2 Interface Problem

Neutron Multigroup Structure (MeV)  
 0.000E+00 5.000E-01 1.000E+00 1.500E+00 2.000E+00 2.500E+00 3.000E+00 3.500E+00  
 4.000E+00 4.500E+00 5.000E+00 5.500E+00 6.000E+00 6.500E+00 7.000E+00 7.500E+00  
 8.000E+00 8.500E+00 9.000E+00 9.500E+00 1.000E+01

=====  
 Title: Alphas at interface ab using region B materials for neutron production

Neutron Spectrum (neuts/cm<sup>2</sup>-sec)  
 9.191E-02 2.006E-03 0.000E+00 0.000E+00 4.118E-03 8.371E-02 1.260E+00 2.401E+00  
 2.489E+00 1.757E+00 1.153E+00 5.039E-01 3.565E-01 2.157E-01 4.469E-02 6.726E-09  
 0.000E+00 0.000E+00 0.000E+00 0.000E+00  
 Total (all groups): 1.036E+01 neutrons/sec-cm<sup>2</sup>.  
 Average Neutron Energy: 4.366E+00 MeV.

Neutron Spectrum (neuts/cm<sup>2</sup>-sec)  
 1.548E-02 2.632E-02 6.630E-02 1.287E-01 1.320E-01 8.993E-02 6.441E-02 3.970E-02  
 2.106E-02 8.260E-03 2.751E-03 1.826E-04 0.000E+00 0.000E+00 0.000E+00 0.000E+00  
 0.000E+00 0.000E+00 0.000E+00 0.000E+00  
 Total (all groups): 5.951E-01 neutrons/sec-cm<sup>2</sup>.  
 Average Neutron Energy: 2.314E+00 MeV.

Neutron Spectrum (neuts/cm<sup>2</sup>-sec)  
 2.182E-01 2.799E-01 6.644E-01 1.295E+00 1.689E+00 1.289E+00 6.079E-01 1.665E-01  
 1.769E-02 1.633E-08 0.000E+00 0.000E+00 0.000E+00 0.000E+00 0.000E+00 0.000E+00  
 0.000E+00 0.000E+00 0.000E+00 0.000E+00  
 Total (all groups): 6.227E+00 neutrons/sec-cm<sup>2</sup>.  
 Average Neutron Energy: 2.148E+00 MeV.

-----  
 Total Neutron Spectrum  
 3.256E-01 3.083E-01 7.307E-01 1.423E+00 1.825E+00 1.463E+00 1.933E+00 2.607E+00  
 2.527E+00 1.765E+00 1.156E+00 5.041E-01 3.565E-01 2.157E-01 4.469E-02 6.726E-09  
 0.000E+00 0.000E+00 0.000E+00 0.000E+00  
 Total (all groups): 1.718E+01 neutrons/sec-cm<sup>2</sup>.  
 Average Neutron Energy: 3.491E+00 MeV.

=====  
 Title: Alphas at interface bc using region B materials for neutron production

Neutron Spectrum (neuts/cm<sup>2</sup>-sec)  
 0.000E+00 0.000E+00 0.000E+00 0.000E+00 2.943E-11 0.000E+00 0.000E+00 0.000E+00

0.000E+00 0.000E+00 0.000E+00 0.000E+00 0.000E+00 0.000E+00 0.000E+00 0.000E+00  
0.000E+00 0.000E+00 0.000E+00 0.000E+00

Total (all groups): 2.943E-11 neutrons/sec-cm<sup>2</sup>.  
Average Neutron Energy: 2.089E+00 MeV.

Neutron Spectrum (neuts/cm<sup>2</sup>-sec)

0.000E+00 0.000E+00 0.000E+00 0.000E+00 0.000E+00 0.000E+00 0.000E+00 0.000E+00  
0.000E+00 0.000E+00 0.000E+00 0.000E+00 0.000E+00 0.000E+00 0.000E+00 0.000E+00  
0.000E+00 0.000E+00 0.000E+00 0.000E+00

Total (all groups): 0.000E+00 neutrons/sec-cm<sup>2</sup>.  
Average Neutron Energy: 0.000E+00 MeV.

Neutron Spectrum (neuts/cm<sup>2</sup>-sec)

0.000E+00 0.000E+00 0.000E+00 0.000E+00 0.000E+00 0.000E+00 0.000E+00 0.000E+00  
0.000E+00 0.000E+00 0.000E+00 0.000E+00 0.000E+00 0.000E+00 0.000E+00 0.000E+00  
0.000E+00 0.000E+00 0.000E+00 0.000E+00

Total (all groups): 0.000E+00 neutrons/sec-cm<sup>2</sup>.  
Average Neutron Energy: 0.000E+00 MeV.

-----  
Total Neutron Spectrum

0.000E+00 0.000E+00 0.000E+00 0.000E+00 2.943E-11 0.000E+00 0.000E+00 0.000E+00  
0.000E+00 0.000E+00 0.000E+00 0.000E+00 0.000E+00 0.000E+00 0.000E+00 0.000E+00  
0.000E+00 0.000E+00 0.000E+00 0.000E+00

Total (all groups): 2.943E-11 neutrons/sec-cm<sup>2</sup>.  
Average Neutron Energy: 3.491E+00 MeV.

=====  
Title: Alphas at interface bc using region C materials for neutron production

Neutron Spectrum (neuts/cm<sup>2</sup>-sec)

0.000E+00 1.642E-08 3.823E-09 0.000E+00 0.000E+00 0.000E+00 0.000E+00 0.000E+00  
0.000E+00 0.000E+00 0.000E+00 0.000E+00 0.000E+00 0.000E+00 0.000E+00 0.000E+00  
0.000E+00 0.000E+00 0.000E+00 0.000E+00

Total (all groups): 2.024E-08 neutrons/sec-cm<sup>2</sup>.  
Average Neutron Energy: 9.874E-01 MeV.

Neutron Spectrum (neuts/cm<sup>2</sup>-sec)

2.732E-08 0.000E+00 0.000E+00 0.000E+00 0.000E+00 0.000E+00 0.000E+00 0.000E+00  
0.000E+00 0.000E+00 0.000E+00 0.000E+00 0.000E+00 0.000E+00 0.000E+00 0.000E+00  
0.000E+00 0.000E+00 0.000E+00 0.000E+00

Total (all groups): 2.732E-08 neutrons/sec-cm<sup>2</sup>.  
Average Neutron Energy: 1.510E-01 MeV.

Neutron Spectrum (neuts/cm<sup>2</sup>-sec)

0.000E+00 0.000E+00 0.000E+00 0.000E+00 0.000E+00 0.000E+00 0.000E+00 0.000E+00  
0.000E+00 0.000E+00 0.000E+00 0.000E+00 0.000E+00 0.000E+00 0.000E+00 0.000E+00  
0.000E+00 0.000E+00 0.000E+00 0.000E+00

Total (all groups): 0.000E+00 neutrons/sec-cm<sup>2</sup>.  
Average Neutron Energy: 0.000E+00 MeV.

-----  
Total Neutron Spectrum

2.732E-08 1.642E-08 3.823E-09 0.000E+00 0.000E+00 0.000E+00 0.000E+00 0.000E+00  
0.000E+00 0.000E+00 0.000E+00 0.000E+00 0.000E+00 0.000E+00 0.000E+00 0.000E+00

0.000E+00 0.000E+00 0.000E+00 0.000E+00

Total (all groups): 4.757E-08 neutrons/sec-cm<sup>2</sup>.  
Average Neutron Energy: 3.491E+00 MeV.

=====  
Title: Total neutron production from all interfaces  
-----

Total Neutron Spectrum

3.256E-01 3.083E-01 7.307E-01 1.423E+00 1.825E+00 1.463E+00 1.933E+00 2.607E+00  
2.527E+00 1.765E+00 1.156E+00 5.041E-01 3.565E-01 2.157E-01 4.469E-02 6.726E-09  
0.000E+00 0.000E+00 0.000E+00 0.000E+00

Total (all groups): 1.718E+01 neutrons/sec-cm<sup>2</sup>.  
Average Neutron Energy: 3.492E+00 MeV.



## **APPENDIX B**

### **Energy-Dependent, Thick-Target Yields for Various Target Materials**

This appendix contains thick-target yield data (neutrons/incident  $\alpha$ -particle) for several  $\alpha$ -particle energies and numerous materials. This section includes both the SOURCES 4A calculated data and data from experiments contained in the literature. Plots of the calculated and measured energy-dependent thick-target yields for various materials are shown in Figs. B-1 through B-11. Following these plots are tables showing the actual data used to construct the figures. The measured data are referenced in both Section VIII and Appendix C.

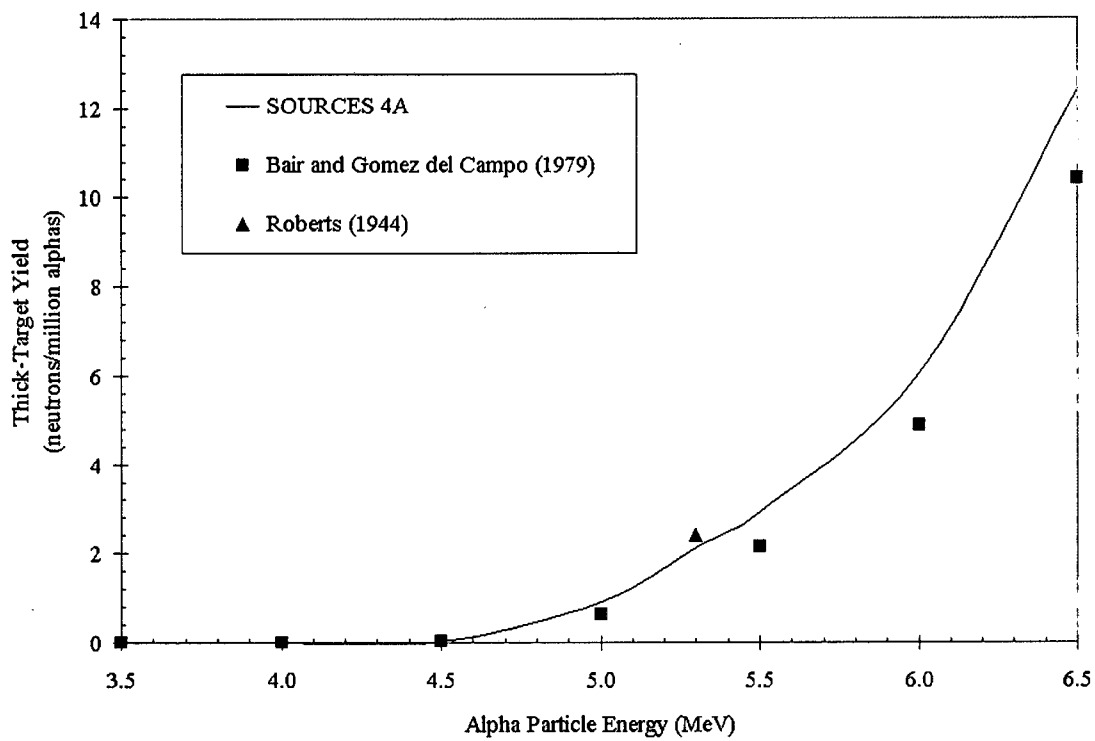

Fig. B-1. Energy-Dependent Thick-Target Yields as Calculated by SOURCES 4A and Compared to Measured Data for Lithium.

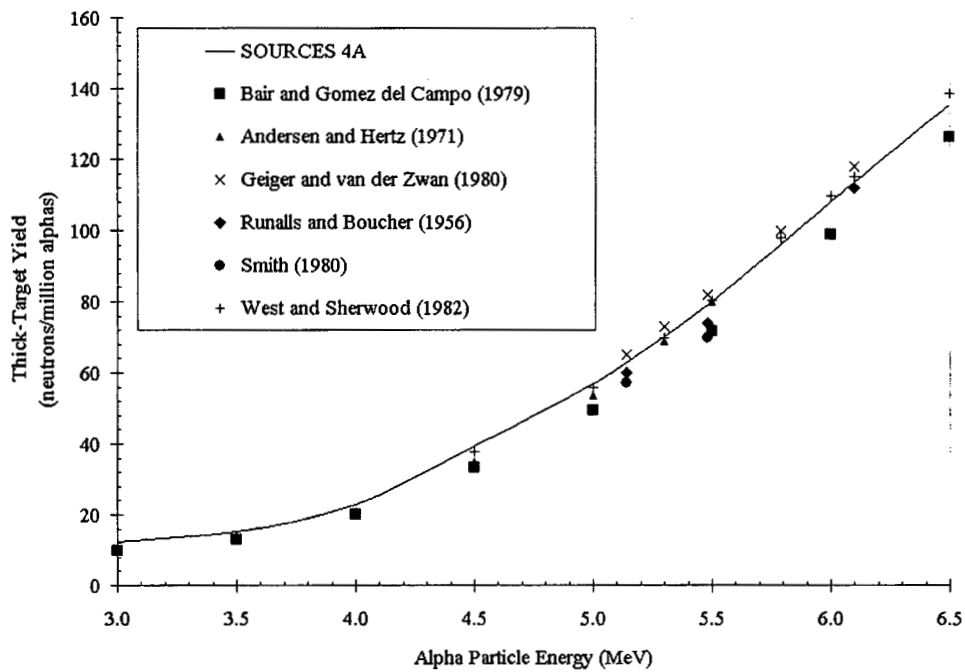

Fig. B-2. Energy-Dependent Thick-Target Yields as Calculated by SOURCES 4A and Compared to Measured Data for Beryllium.

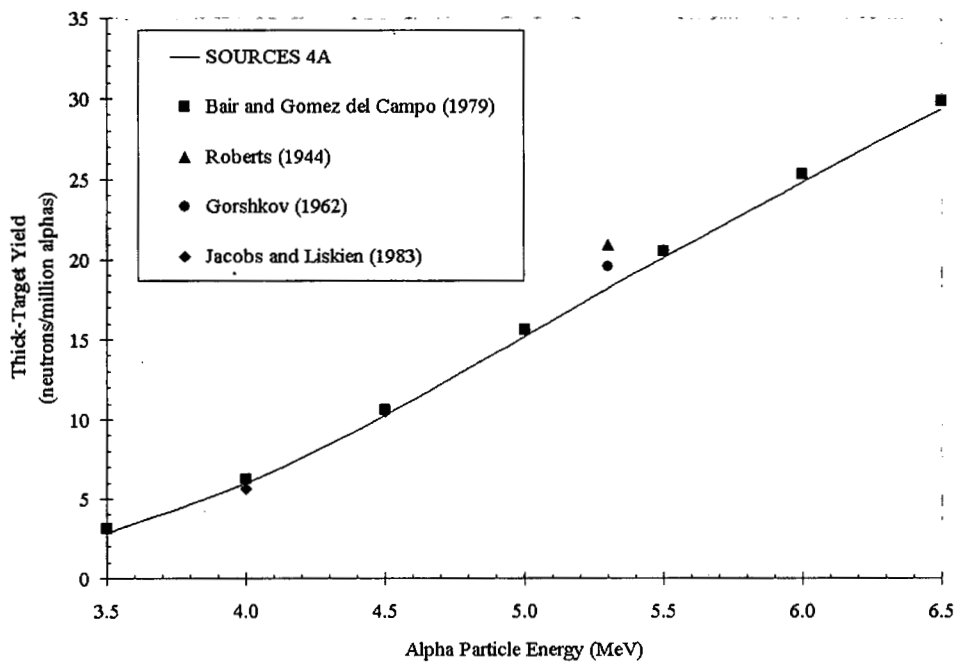

Fig. B-3. Energy-Dependent Thick-Target Yields as Calculated by SOURCES 4A and Compared to Measured Data for Boron.

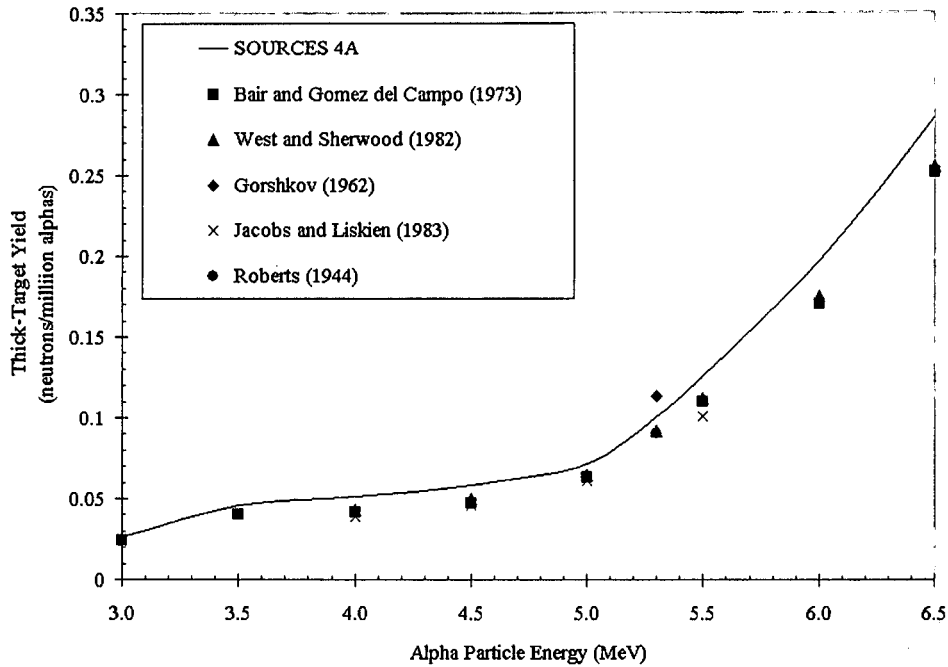

Fig. B-4. Energy-Dependent Thick-Target Yields as Calculated by SOURCES 4A and Compared to Measured Data for Carbon.

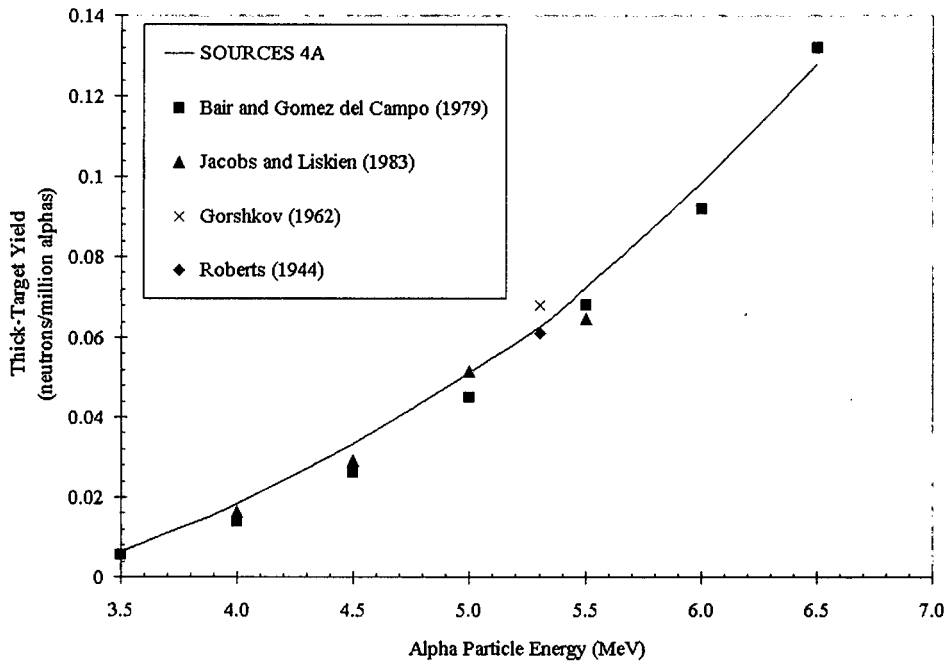

Fig. B-5. Energy-Dependent Thick-Target Yields as Calculated by SOURCES 4A and Compared to Measured Data for Oxygen.

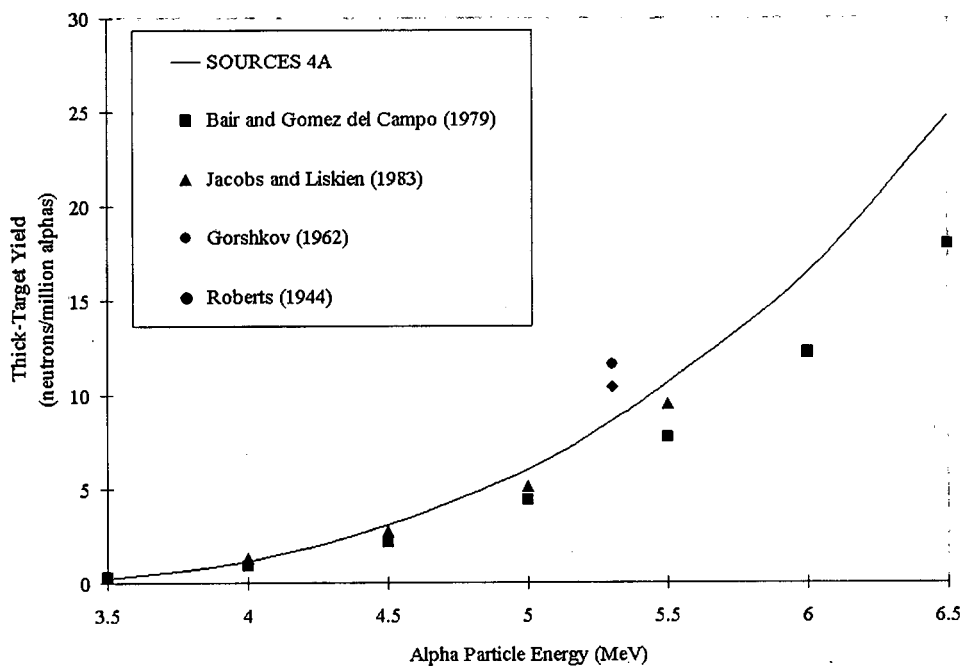

Fig. B-6. Energy-Dependent Thick-Target Yields as Calculated by SOURCES 4A and Compared to Measured Data for Fluorine.

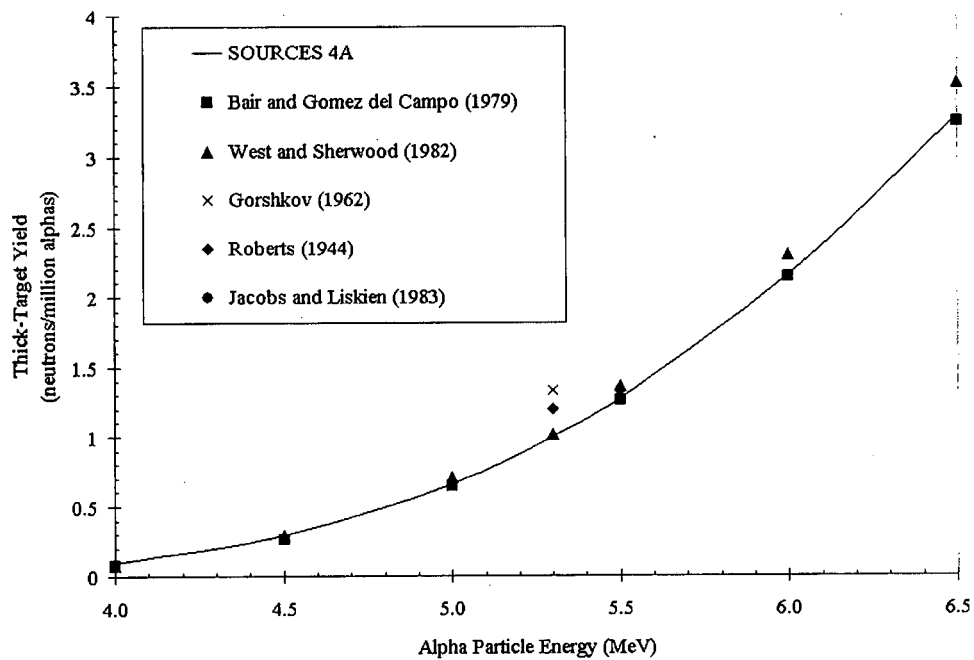

Fig. B-7. Energy-Dependent Thick-Target Yields as Calculated by SOURCES 4A and Compared to Measured Data for Magnesium.

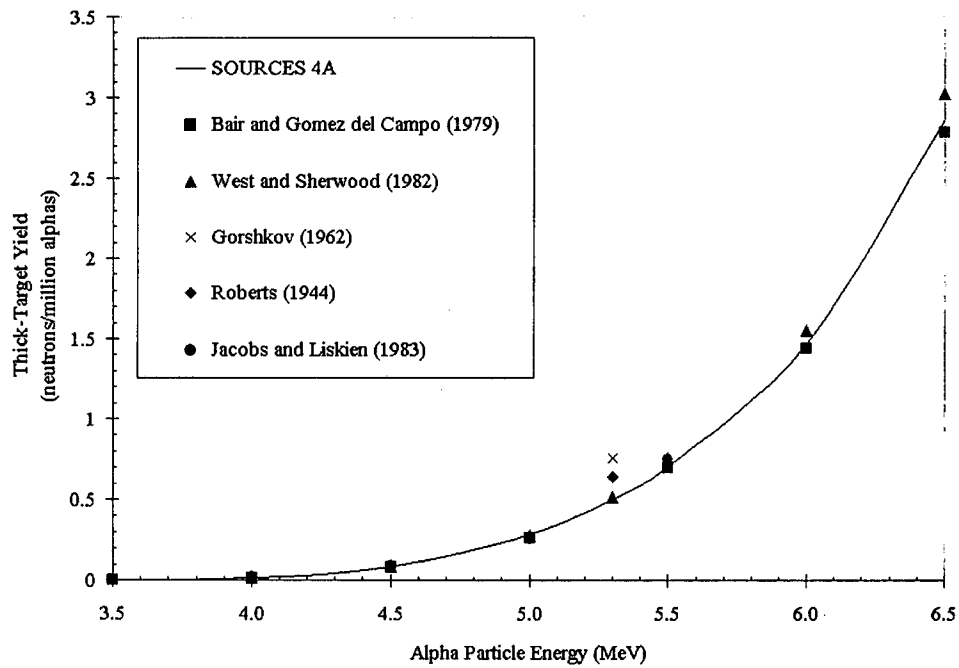

Fig. B-8. Energy-Dependent Thick-Target Yields as Calculated by SOURCES 4A and Compared to Measured Data for Aluminum.

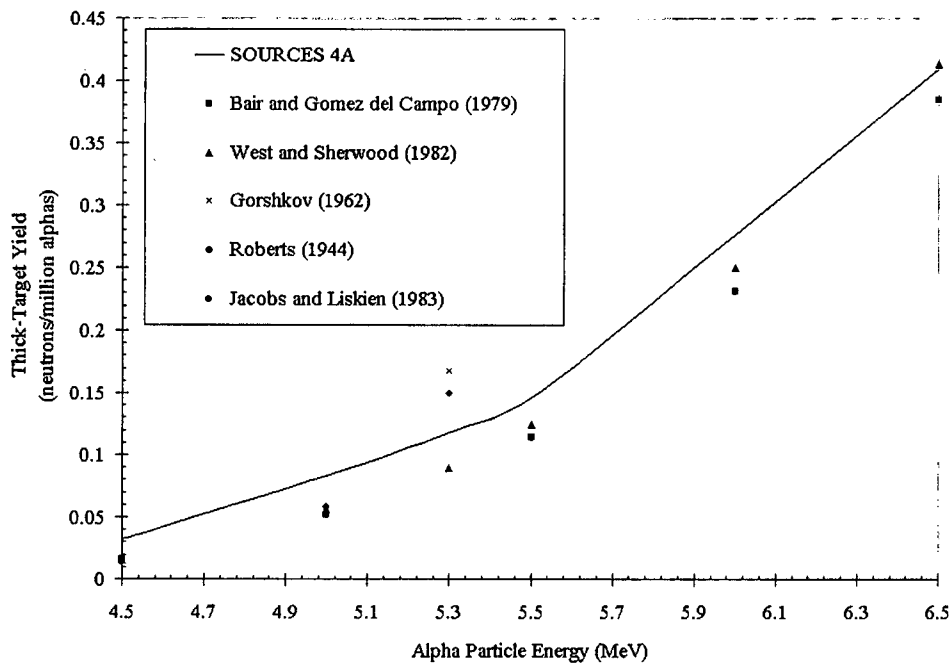

Fig. B-9. Energy-Dependent Thick-Target Yields as Calculated by SOURCES 4A and Compared to Measured Data for Silicon.

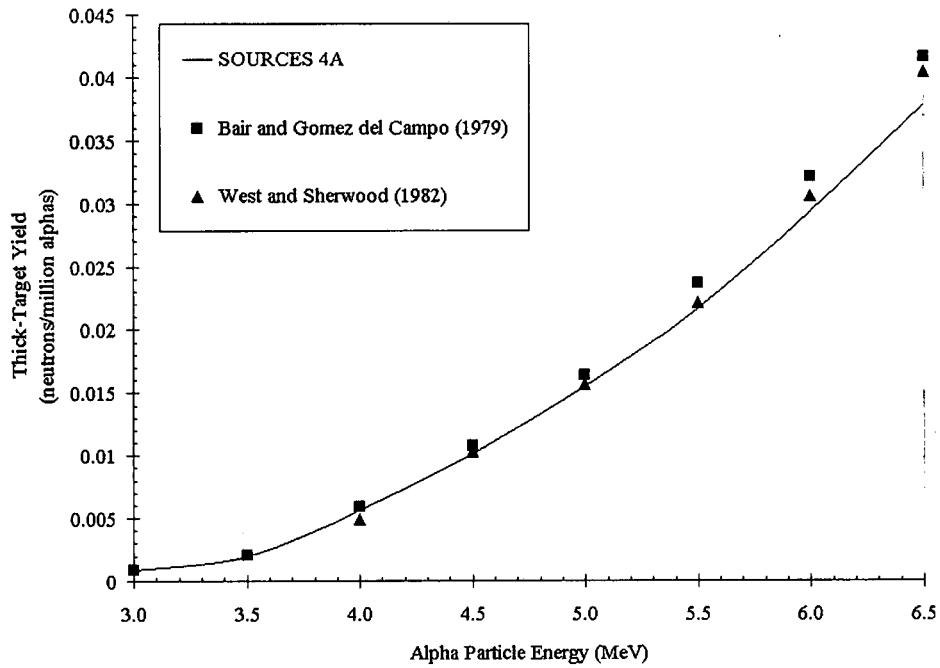

Fig. B-10. Energy-Dependent Thick-Target Yields as Calculated by SOURCES 4A and Compared to Measured Data for Uranium Dioxide.

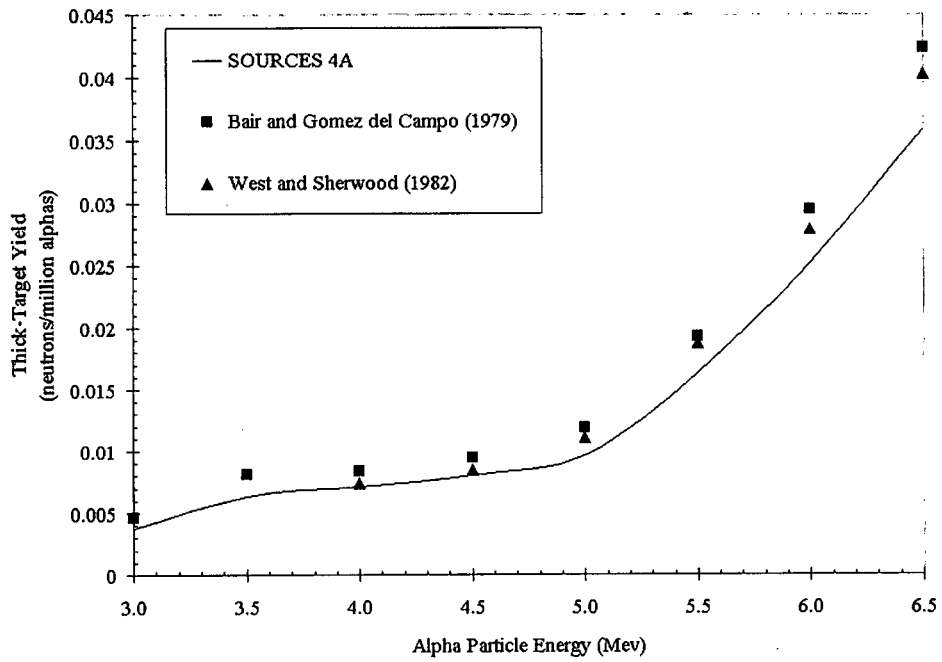

Fig. B-11. Energy-Dependent Thick-Target Yields as Calculated by SOURCES 4A and Compared to Measured Data for Uranium Carbide.

### Thick Target Yield Data

( $\alpha$ -Particle Energies in MeV and Yields in neutrons/million  $\alpha$ -particles)

#### Natural Lithium Target

| $E_{\alpha}$ | <u>SOURCES 4A</u> | <u>Ref. 8</u> | <u>Ref. C-5</u> |
|--------------|-------------------|---------------|-----------------|
| 3.5          | 0                 | 0.001         |                 |
| 4            | 0                 | 0.002         |                 |
| 4.5          | 0.033964562       | 0.028         |                 |
| 5            | 0.909993912       | 0.629         |                 |
| 5.3          | 2.137204012       |               | 2.4             |
| 5.5          | 2.919029767       | 2.15          |                 |
| 6            | 6.039924381       | 4.873         |                 |
| 6.5          | 12.39706495       | 10.41         |                 |

#### Be-9 Target

| $E_{\alpha}$ | <u>SOURCES 4A</u> | <u>Ref. 8</u> | <u>Ref. C-1</u> | <u>Ref. 7</u> | <u>Ref. C-6</u> | <u>Ref. C-8</u> | <u>Ref. C-7</u> |
|--------------|-------------------|---------------|-----------------|---------------|-----------------|-----------------|-----------------|
| 3            | 12.25928418       | 9.79          | 10.05           |               |                 |                 |                 |
| 3.5          | 15.34813676       | 12.97         | 14.4            |               |                 |                 |                 |
| 4            | 22.78509404       | 19.88         | 21.1            |               |                 |                 |                 |
| 4.5          | 39.22906854       | 33.27         | 34.8            |               |                 | 37.63           |                 |
| 5            | 56.71440931       | 49.43         | 53.5            |               |                 | 55.87           |                 |
| 5.14         | 62.74151687       |               |                 | 65            | 60              |                 | 57              |
| 5.3          | 70.13681951       |               | 69              | 73            |                 | 69.77           |                 |
| 5.48         | 79.04130219       |               |                 | 82            | 74              |                 | 70              |
| 5.5          | 80.06344324       | 71.81         | 80              |               |                 | 80.46           |                 |
| 5.79         | 96.26710244       |               |                 | 100           |                 | 98.17           |                 |
| 6            | 108.1450864       | 99.16         |                 |               |                 | 109.7           |                 |
| 6.1          | 113.5826204       |               |                 | 118           | 112             | 115.3           |                 |
| 6.5          | 135.6019097       | 126.2         |                 |               |                 | 138.7           |                 |



**Natural Boron Target**

| <u>E<sub>a</sub></u> | <u>SOURCES 4A</u> | <u>Ref. 8</u> | <u>Ref. C-5</u> | <u>Ref. C-2</u> | <u>Ref. 18</u> |
|----------------------|-------------------|---------------|-----------------|-----------------|----------------|
| 3.5                  | 2.8645583         | 3.15          |                 |                 |                |
| 4                    | 6.004678138       | 6.238         |                 |                 | 5.6            |
| 4.5                  | 10.25665673       | 10.63         |                 |                 | 10.5           |
| 5                    | 15.21676439       | 15.64         |                 |                 | 15.6           |
| 5.3                  | 18.20308244       |               | 21              | 19.6            |                |
| 5.5                  | 20.14162581       | 20.59         |                 |                 | 20.6           |
| 6                    | 24.8774392        | 25.35         |                 |                 |                |
| 6.5                  | 29.36332468       | 29.85         |                 |                 |                |

**Natural Carbon Target**

| <u>E<sub>a</sub></u> | <u>SOURCES 4A</u> | <u>Ref. 8</u> | <u>Ref. C-8</u> | <u>Ref. C-2</u> | <u>Ref. 18</u> | <u>Ref. C-5</u> |
|----------------------|-------------------|---------------|-----------------|-----------------|----------------|-----------------|
| 3                    | 0.02608222        | 0.024         |                 |                 |                |                 |
| 3.5                  | 0.045820116       | 0.04          |                 |                 |                |                 |
| 4                    | 0.051267263       | 0.042         | 0.04329         |                 | 0.039          |                 |
| 4.5                  | 0.058316511       | 0.047         | 0.0497          |                 | 0.046          |                 |
| 5                    | 0.071453747       | 0.063         | 0.06468         |                 | 0.061          |                 |
| 5.3                  | 0.100932423       |               | 0.09136         | 0.113           |                | 0.09            |
| 5.5                  | 0.125604793       | 0.11          | 0.1116          |                 | 0.101          |                 |
| 6                    | 0.197058541       | 0.17          | 0.1748          |                 |                |                 |
| 6.5                  | 0.285814989       | 0.252         | 0.2555          |                 |                |                 |

**Natural Oxygen Target**

| <u>E<sub>a</sub></u> | <u>SOURCES 4A</u> | <u>Ref. 8</u> | <u>Ref. 18</u> | <u>Ref. C-2</u> | <u>Ref. C-5</u> |
|----------------------|-------------------|---------------|----------------|-----------------|-----------------|
| 3.5                  | 0.006376366       | 0.0056        |                |                 |                 |
| 4                    | 0.018360088       | 0.014         | 0.0164         |                 |                 |
| 4.5                  | 0.033323721       | 0.026         | 0.0293         |                 |                 |
| 5                    | 0.051267263       | 0.045         | 0.0518         |                 |                 |
| 5.3                  | 0.062802397       |               |                | 0.068           | 0.061           |
| 5.5                  | 0.072415008       | 0.068         | 0.0646         |                 |                 |
| 6                    | 0.098689481       | 0.0919        |                |                 |                 |
| 6.5                  | 0.128168157       | 0.132         |                |                 |                 |

**Fluorine Target**

| <u>E<sub>a</sub></u> | <u>SOURCES 4A</u> | <u>Ref. 8</u> | <u>Ref. 18</u> | <u>Ref. C-2</u> | <u>Ref. C-5</u> |
|----------------------|-------------------|---------------|----------------|-----------------|-----------------|
| 3.5                  | 0.209875356       | 0.31          |                |                 |                 |
| 4                    | 1.15351341        | 0.879         | 1.28           |                 |                 |
| 4.5                  | 3.076035759       | 2.159         | 2.76           |                 |                 |
| 5                    | 6.033515973       | 4.394         | 5.09           |                 |                 |
| 5.3                  | 8.612900125       |               |                | 11.6            | 10.4            |
| 5.5                  | 10.62514018       | 7.746         | 9.5            |                 |                 |
| 6                    | 16.50485437       | 12.26         |                |                 |                 |
| 6.5                  | 24.84860136       | 17.95         |                |                 |                 |

### Natural Magnesium Target

| <u>E<sub>n</sub></u> | <u>SOURCES 4A</u> | <u>Ref. 8</u> | <u>Ref. C-8</u> | <u>Ref. C-2</u> | <u>Ref. C-5</u> | <u>Ref. 18</u> |
|----------------------|-------------------|---------------|-----------------|-----------------|-----------------|----------------|
| 4                    | 0.097407799       | 0.077         | 0.08272         |                 |                 | 0.073          |
| 4.5                  | 0.291902977       | 0.263         | 0.2932          |                 |                 | 0.26           |
| 5                    | 0.660066007       | 0.644         | 0.7039          |                 |                 | 0.665          |
| 5.3                  | 0.999711622       |               | 1.018           | 1.33            | 1.2             |                |
| 5.5                  | 1.278477362       | 1.262         | 1.368           |                 |                 | 1.33           |
| 6                    | 2.159633439       | 2.141         | 2.298           |                 |                 |                |
| 6.5                  | 3.293921625       | 3.25          | 3.523           |                 |                 |                |

### Natural Aluminum Target

| <u>E<sub>n</sub></u> | <u>SOURCES 4A</u> | <u>Ref. 8</u> | <u>Ref. C-8</u> | <u>Ref. C-2</u> | <u>Ref. C-5</u> | <u>Ref. 18</u> |
|----------------------|-------------------|---------------|-----------------|-----------------|-----------------|----------------|
| 3.5                  | 0.000839501       | 0.0012        |                 |                 |                 |                |
| 4                    | 0.015828767       | 0.0169        | 0.01655         |                 |                 | 0.019          |
| 4.5                  | 0.082988881       | 0.0802        | 0.08124         |                 |                 | 0.087          |
| 5                    | 0.281329104       | 0.2643        | 0.2812          |                 |                 | 0.26           |
| 5.3                  | 0.496651607       |               | 0.5119          | 0.76            | 0.64            |                |
| 5.5                  | 0.698516454       | 0.6967        | 0.7555          |                 |                 | 0.747          |
| 6                    | 1.467525393       | 1.438         | 1.549           |                 |                 |                |
| 6.5                  | 2.854945689       | 2.78          | 3.015           |                 |                 |                |

### Natural Silicon Target

| <u>E<sub>n</sub></u> | <u>SOURCES 4A</u> | <u>Ref. 8</u> | <u>Ref. C-8</u> | <u>Ref. C-2</u> | <u>Ref. C-5</u> | <u>Ref. 18</u> |
|----------------------|-------------------|---------------|-----------------|-----------------|-----------------|----------------|
| 4.5                  | 0.031785703       | 0.016         | 0.0156          |                 |                 | 0.0138         |
| 5                    | 0.083309302       | 0.052         | 0.05649         |                 |                 | 0.0581         |
| 5.3                  | 0.117594284       |               | 0.08954         | 0.168           | 0.15            |                |
| 5.5                  | 0.146432119       | 0.114         | 0.1245          |                 |                 | 0.113          |
| 6                    | 0.277163639       | 0.231         | 0.2504          |                 |                 |                |
| 6.5                  | 0.410138101       | 0.385         | 0.4131          |                 |                 |                |

### Uranium Dioxide

| <u>E<sub>a</sub></u> | <u>SOURCES 4A</u> | <u>Ref. 8</u> | <u>Ref. C-8</u> |
|----------------------|-------------------|---------------|-----------------|
| 3                    | 0.000852318       | 0.00091       |                 |
| 3.5                  | 0.001960973       | 0.00208       |                 |
| 4                    | 0.005607357       | 0.00593       | 0.004935        |
| 4.5                  | 0.010125284       | 0.0107        | 0.0103          |
| 5                    | 0.015476305       | 0.0164        | 0.01568         |
| 5.5                  | 0.021660418       | 0.0236        | 0.02208         |
| 6                    | 0.029318466       | 0.0321        | 0.03061         |
| 6.5                  | 0.037809606       | 0.0416        | 0.04044         |

### Uranium Carbide

| <u>E<sub>a</sub></u> | <u>SOURCES 4A</u> | <u>Ref. 8</u> | <u>Ref. C-8</u> |
|----------------------|-------------------|---------------|-----------------|
| 3                    | 0.003716877       | 0.00468       |                 |
| 3.5                  | 0.006376366       | 0.0081        |                 |
| 4                    | 0.007113333       | 0.00842       | 0.007432        |
| 4.5                  | 0.00801051        | 0.00943       | 0.008472        |
| 5                    | 0.009676696       | 0.0119        | 0.01104         |
| 5.5                  | 0.016373482       | 0.0193        | 0.01879         |
| 6                    | 0.025153001       | 0.0295        | 0.02793         |
| 6.5                  | 0.035887084       | 0.0423        | 0.04023         |

**APPENDIX C**  
**General Bibliography**

- C-1. M. E. ANDERSON and M. R. HERTZ, "Thick Target Yields for the Be( $\alpha$ ,n) Reaction," *Nucl. Sci. Eng.* **44**, page 437 (1971).
- C-2. G. V. GORSHKOV, V. A. ZYABKIN, and O. S. TSVETKOV, "Neutron Yield from the Reaction ( $\alpha$ ,n) in Be, C, O, F, Mg, Al, Si, and Granite Irradiated with Polonium  $\alpha$ -Particles," *Atomnaya Energiya* **13**, page 65 (1962).
- C-3. R. T. PERRY and W. B. WILSON, "Alpha-N and Spontaneous Fission Sources from Individual Plutonium Isotopes in PuF<sub>4</sub> and PuO<sub>2</sub>," Los Alamos National Laboratory document LA-UR-96-1859 (1996).
- C-4. R. T. PERRY, W. B. WILSON, T. H. BROWN, and T. A. PARISH, "(Alpha,n) Neutron Sources and Spectra at the Interface of an Alpha Source Region and a Neutron Producing Region," *Trans. Am. Nucl. Soc.* **76**, page 343 (1997).
- C-5. J. H. ROBERTS, "Neutron Yields of Several Light Elements Bombarded with Polonium Alpha Particles," MMDC-731 (1944).
- C-6. O. J. C. RUNALLS and R. R. BOUCHER, "Neutron Yields from Actinide-Beryllium Alloys," *Can. J. Phys.* **34**, page 949 (1956).
- C-7. A. B. SMITH, "Neutron Sources in Perspective," INDC(NDS)-114/GT, page 19 (1980).
- C-8. D. WEST and A. C. SHERWOOD, "Measurements of Thick-Target ( $\alpha$ ,n) Yields from Light Elements," *Ann. Nucl. Energy* **9**, page 551 (1982).
- C-9. W. B. WILSON, T. R. ENGLAND, W. C. HOPKINS, and R. T. PERRY, "SOURCES Calculation of TMI-2 Spontaneous-Fission and ( $\alpha$ ,n) Neutron Sources," Los Alamos National Laboratory report LA-10288-PR, page 61 (1984).

C-10. R. T. PERRY and W. B. WILSON, "Neutron Production from (alpha,n) Reactions and Spontaneous Fission in ThO<sub>2</sub>, UO<sub>2</sub>, and (U, Pu)O<sub>2</sub> Fuels," Los Alamos Scientific Laboratory report LA-8869-MS (1981).

C-11. W. B. WILSON, R. T. PERRY, J. E. STEWART, T. R. ENGLAND, D. G. MADLAND, and E. D. ARTHUR, "Development of Sources Code and Data Library for the Calculation of Neutron Sources and Spectra from (alpha,n) Reactions, Spontaneous Fission, (β<sup>-</sup>, n) and Delayed Neutrons," Los Alamos National Laboratory report LA-9841-PR, pages 65-66 (1983).

C-12. W. B. WILSON, R. T. PERRY, J. E. STEWART, T. R. ENGLAND, D. G. MADLAND, and E. D. ARTHUR, "Development of Methodology for Calculating (alpha, n), Spontaneous Fission, and β<sup>-</sup> Delayed Neutron Sources and Spectra in Reactor Fuels," Oak Ridge National Laboratory *Actinide Newsletter*, issue 7, page 40 (1984).

C-13. W. B. WILSON, R. T. PERRY, J. E. STEWART, T. R. ENGLAND, E. D. ARTHUR, and D. G. MADLAND, "Development of SOURCES Code and Data Library for the Calculation of (alpha, n), Delayed Neutrons, (gamma,n) and Spontaneous Fission Decay Neutron Sources and Spectra," in *Reports to the DOE Nuclear Data Committee*, Brookhaven National Laboratory report BNL-NCS-34291, pages 113-114 (1984).

C-14. W. B. WILSON and R. T. PERRY, "Evaluation of <sup>10,11</sup>B(alpha, n) Cross Sections," in *Applied Nuclear Science Research and Development Progress Report, June 1, 1985-November 30, 1985*, Los Alamos National Laboratory progress report LA-10689-PR, pages 96-98 (1986).

C-15. W. B. WILSON, M. BOZOIAN, and R. T. PERRY, "Calculated Alpha-Induced Thick Target Neutron Yields and Spectra, with Comparison to Measured Data," *Proceedings of the International Conference on Nuclear Data for Science and Technology*, Mito, Japan, May 30–June 3, 1988, pages 1193-1197 (1988).

- C-16. R. T. PERRY, W. B. WILSON, T. H. BROWN, and T. PARISH, "(Alpha,n) Neutron Sources and Spectra at the Interface of an Alpha Source Region and a Neutron Producing Region," *Trans. Am. Nucl. Soc.* **76**, page 343 (1997).
- C-17. R. T. PERRY and W. B. WILSON, "Neutron Production from (alpha,n) Reactions in PuO<sub>2</sub>, UO<sub>2</sub>, and ThO<sub>2</sub> Fuels," *Trans. Am. Nucl. Soc.* **35**, page 549 (1980).
- C-18. W. B. WILSON, J. E. STEWART, and R. T. PERRY, "Neutron Production in UF<sub>6</sub> from the Decay of Uranium Nuclides," *Trans. Am. Nucl. Soc.* **38**, page 176 (1981).
- C-19. R. T. PERRY and W. B. WILSON, "On the (alpha,n) Neutron Production in Boron-Containing Systems," *Trans. Am. Nucl. Soc.* **46**, page 763 (1984).
- C-20. R. T. PERRY, T. A. PARISH, and W. B. WILSON, "A 14 MeV Neutron Source," *Fusion Technology* **8(1)**, page 1454 (1985).
- C-21. W. B. WILSON, J. E. STEWART, T. R. ENGLAND, and R. T. PERRY, "Calculations of Neutron Sources and Spectra in a PWR Fuel," *Trans. Am. Nucl. Soc.* **50**, page 569 (1985).
- C-22. T. A. PARISH, R. T. PERRY, and W. B. WILSON, "Neutron Sources and Spectra from Cold Fusion," *Journal of Fusion Energy* **9(4)**, page 479 (1990).
- C-23. R. T. PERRY and W. B. WILSON, "Neutron Sources and Spectra from Cold Fusion," Los Alamos National Laboratory document LA-UR-89-1678 (Revised).
- C-24. R. T. PERRY, "Neutron Radiation Damage from Actinide Decay and Fission in the Hanford Waste Tanks," Los Alamos National Laboratory publication LALP 93-84, page 184 (1983).



C-25. R. T. PERRY, "Neutron and Gamma Sources in Hanford Waste Tank 241-101-SY," *Proceedings 8th International Conference on Radiation Shielding*, Arlington, Texas, April 24–28, 1994, pages 523-527 (1994).

C-26. R. T. PERRY, "Estimation of Neutron Radiation Damage from Actinide Decay and Fission in the Hanford Waste Tanks," *Journal of Alloys and Compounds* **213/214**, page 560 (1994).

C-27. R. T. PERRY and W. B. WILSON, "Alpha-n and Spontaneous Fission Sources and Spectra from Individual Plutonium Isotopes in PuF<sub>4</sub> and PuO<sub>2</sub>," *Trans. Am. Nucl. Soc.* **75**, page 299 (1996).

C-28. D. E. KORNREICH, S. T. BOERIGTER, M. G. HOUTS, R. T. PERRY, and D. I. POSTON, "Analysis of Salt-to Oxide Procession Schedule for PF-4 Vault Storage Containers Based on Accumulated Neutron Dose Equivalent," Los Alamos National Laboratory report LA-CP-96-172 (1996).

C-29. W. B. WILSON, M. BOZOIAN, and R. T. PERRY, "Calculated Alpha-Induced Thick-Target Neutron Yields and Spectra," *Reports to the DOE Nuclear Data Committee*, Brookhaven National Laboratory report BNL-NCS-40911, p. 108 (1988).

C-30. W. B. WILSON, R. T. PERRY, J. E. STEWART, and T. R. ENGLAND, "Calculation of Neutron Sources in PWR Fuel," *Applied Nuclear Science Research and Development Progress Report, June 1, 1984–May 31, 1985*, Los Alamos National Laboratory progress report LA-10513-PR, pages 42-44 (1985).

C-31. R. T. PERRY, T. A. PARISH, and W. B. WILSON, "Feasibility Study of a Thermal Neutron Driven 14-MeV Neutron Source," *Applied Nuclear Science Research and Development Progress Report, June 1, 198–May 31, 1985*, Los Alamos National Laboratory progress report LA-10513-PR, pages 49-51 (1985).

C-32. W. B. WILSON, R. T. PERRY, J. E. STEWART, and T. R. ENGLAND, "Neutron Sources in Reactor Fuel," *Reports to the DOE Nuclear Data Committee*, Brookhaven National Laboratory report BNL-NCS-36272, pages 99-100 (1985).

C-33. W. B. WILSON, T. R. ENGLAND, W. C. HOPKINS, and R. T. PERRY, "SOURCES Calculation of TMI-2 Spontaneous-Fission and ( $\alpha$ ,n) Neutron Sources," *Applied Nuclear Science Research and Development Semiannual Progress Report, October 1, 1983–May 31, 1984*, Los Alamos National Laboratory progress report LA-10288-PR, pages 61-62 (1985).

C-34. R. T. PERRY and W. B. WILSON, "( $\alpha$ ,n), Neutron production in Boron-Containing Systems," *Applied Nuclear Data Research and Development, Semiannual Progress Report, April 1, 1983–September 30, 1983*, Los Alamos National Laboratory progress report LA-10069-PR, pages 86-87 (1984).

C-35. W. B. WILSON, R. T. PERRY, and J. E. STEWART, "Neutron Production in  $UO_2F_2$  from the Spontaneous Fission and Alpha Decay of U Nuclides and Subsequent  $^{17,18}O(\alpha,n)$  and  $^{19}F(\alpha,n)$  Reactions," *Applied Nuclear Data Research and Development Progress Report, April 1, 1981–June 30, 1981*, Los Alamos National Laboratory progress report LA-9060-PR, pages 50-51 (1981).

C-36. W. B. WILSON, R. T. PERRY, D. G. MADLAND, N. ENSSLIN, and J. E. STEWART, "Calculated Neutron Sources in Pu Process Solutions," *Applied Nuclear Data Research and Development Progress Report, October 1, 1981–March 31, 1982*, Los Alamos National Laboratory progress report LA-9468-PR, pages 75-79 (1982).

C-37. W. B. WILSON and R. T. PERRY, "Calculated Neutron Sources in Plutonium Oxalate," *Applied Nuclear Data Research and Development Progress Report, April 1,*

1982–September 30, 1982, Los Alamos National Laboratory progress report LA-9647-PR, pages 88-91 (1983).

C-38. W. B. WILSON, J. E. STEWART, and R. T. PERRY, "The  $^{19}\text{F}$  ( $\alpha,n$ ) Neutron Production from the Decay of U Nuclides in  $\text{UF}_6$ ," *Applied Nuclear Data Research and Development Progress Report October 1, 1980–December 31, 1980*, Los Alamos National Laboratory progress report LA-8757-PR, pages 40-48 (1981).

C-39. W. B. WILSON, R. T. PERRY, T. R. ENGLAND, R. J. LABAUVE, M. E. BATTAT, and N. L. WHITTEMORE, "Neutron Production from Actinide Decay in Oxide Fuels," *Applied Nuclear Data Research and Development, July 1–September 30, 1980*, Los Alamos National Laboratory progress report LA-8630-PR, pages 23-29 (1980).

C-40. R. T. PERRY and W. B. WILSON, "The ( $\alpha,n$ ) Neutron Production by Alpha Particles in  $\text{PuO}_2$ ,  $\text{UO}_2$ ,  $\text{ThO}_2$  Fuels," *Applied Nuclear Data Research and Development Progress Report, April–June 30, 1980*, Los Alamos National Laboratory progress report LA-8524-PR, pages 20-22 (1980).

C-41. G. P. ESTES, "Benchmarking of the SOURCES 3A Code for PuBe Sources," *Am. Nucl. Soc. Trans.* **79**, page 270 (1998).

C-42. T. H. BROWN, W. B. WILSON, R. T. PERRY, and W. S. CHARLTON, "Comparison of ( $\alpha,n$ ) Thick-Target Neutron Yields and Spectra from ORIGEN-S and SOURCES," *Am. Nucl. Soc. Trans.* **79**, page 272 (1998).

C-43. W. S. CHARLTON and T. A. PARISH, "Alpha-Particle Source Rate and Spectra at the Surface of a Spherical Source Particle," *Am. Nucl. Soc. Trans.* **79**, page 274 (1998).

C-44. M. BALAKRISHNAN, S. KAILAS, and M. K. MEHTA, "A Study of the Reaction  $^{19}\text{F}(\alpha, n)^{22}\text{Na}$  in the Bombarding Energy Range 2.6 to 5.1 MeV," *Pramana* **10**, page 329 (1978).

## **APPENDIX D**

**Los Alamos Scientific Laboratory Report LA-8869-MS**